



BD136-138-140

PNP EPITAXIAL SILICON TRANSISTOR

PNP SILICON TRANSISTOR

DESCRIPTION

The UTC **BD136/BD138/BD140** are silicon epitaxial planer PNP transistor, designed for use as audio amplifiers and drivers utilizing complementary or quasi complementary circuits.

The complementary NPN types are the BD135/BD137/ BD139.

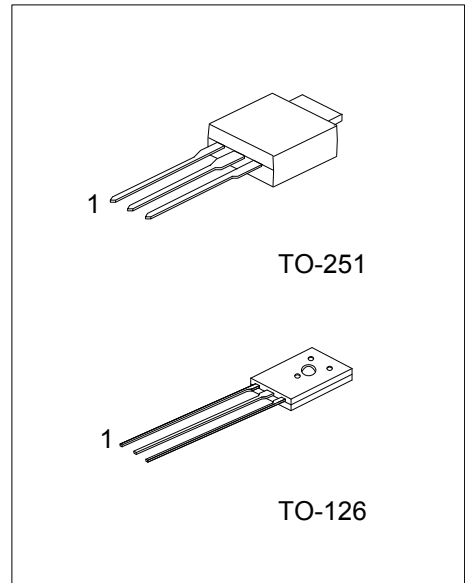

ORDERING INFORMATION

Ordering Number		Package	Pin Assignment			Packing
Lead Free	Halogen Free		1	2	3	
BD136L-x-T60-K	BD136G-x-T60-K	TO-126	E	C	B	Bulk
BD138L-x-T60-K	BD138G-x-T60-K	TO-126	E	C	B	Bulk
BD140L-x-T60-K	BD140G-x-T60-K	TO-126	E	C	B	Bulk
BD136L-x-TM3-T	BD136G-x-TM3-T	TO-251	B	C	E	Tube
BD138L-x-TM3-T	BD138G-x-TM3-T	TO-251	B	C	E	Tube
BD140L-x-TM3-T	BD140G-x-TM3-T	TO-251	B	C	E	Tube

Note: Pin Assignment: E: Emitter C: Collector B: Base

<p>BD136L-x-T60-K</p> <p>(1)Packing Type (2)Package Type (3)Rank (4)Lead Free</p>	<p>(1) K: Bulk, T: Tube (2) T60: TO-126, TM3: TO-251 (3) x: refer to Classification of h_{FE} (4) G: Halogen Free, L: Lead Free</p>
---	--

■ ABSOLUTE MAXIMUM RATING

PARAMETER		SYMBOL	RATINGS	UNIT
Collector-Base Voltage	BD136	V_{CBO}	-45	V
	BD138		-60	
	BD140		-80	
Collector-Emitter Voltage	BD136	V_{CEO}	-45	V
	BD138		-60	
	BD140		-80	
Emitter-Base Voltage		V_{EBO}	-5	V
Collector Current		I_C	-1.5	V
Collector Peak Current		I_{CM}	-3	A
Base Current		I_B	-0.5	A
Power Dissipation	$T_C \leq 25^\circ\text{C}$	TO-126	12.5	W
		TO-251	15	
Junction Temperature		T_J	150	$^\circ\text{C}$
Storage Temperature		T_{STG}	-40 ~ +150	$^\circ\text{C}$

- Note 1. Absolute maximum ratings are those values beyond which the device could be permanently damaged. Absolute maximum ratings are stress ratings only and functional device operation is not implied.
2. The device is guaranteed to meet performance specification within $0^\circ\text{C} \sim 70^\circ\text{C}$ operating temperature range and assured by design from $-20^\circ\text{C} \sim 85^\circ\text{C}$.

■ THERMAL DATA

PARAMETER		SYMBOL	RATINGS	UNIT
Junction to Ambient	TO-126	θ_{JA}	100	$^\circ\text{C/W}$
	TO-251		83	
Junction to Case	TO-126	θ_{JC}	10	$^\circ\text{C/W}$
	TO-251		8.3	

■ ELECTRICAL CHARACTERISTICS ($T_C=25^\circ\text{C}$, unless otherwise specified)

PARAMETER		SYMBOL	TEST CONDITIONS	MIN	TYP	MAX	UNIT
Collector-Emitter Sustaining Voltage	BD136	$V_{CEO(SUS)}$	$I_C = -30\text{mA}, I_B = 0$ (Note)	-45			V
	BD138			-60			
	BD140			-80			
Collector Cut-off Current	I_{CBO}		$V_{CB} = -30\text{V}, I_E = 0$			-0.1	μA
			$V_{CB} = -30\text{V}, I_E = 0, T_C = 125^\circ\text{C}$			-10	
Emitter Cut-off Current		I_{EBO}	$V_{EB} = -5\text{V}, I_C = 0$			-10	μA
DC Current Gain	h_{FE1}		$V_{CE} = -2\text{V}, I_C = -5\text{mA}$	25			
			$V_{CE} = -2\text{V}, I_C = -0.5\text{A}$	25			
			$V_{CE} = -2\text{V}, I_C = -150\text{mA}$	40		250	
Collector-Emitter Saturation Voltage		$V_{CE(SAT)}$	$I_C = -0.5\text{A}, I_B = -0.05\text{A}$ (Note)			-0.5	V
Base-Emitter Voltage		V_{BE}	$I_C = -0.5\text{A}, V_{CE} = -2\text{V}$ (Note)			-1	V

Note: Pulsed: Pulse duration $\leq 300\mu\text{s}$, duty cycle 1.5 %

■ CLASSIFICATION OF h_{FE3}

RANK	6	10	16
RANGE	40~100	63~160	100~250

UTC assumes no responsibility for equipment failures that result from using products at values that exceed, even momentarily, rated values (such as maximum ratings, operating condition ranges, or other parameters) listed in products specifications of any and all UTC products described or contained herein. UTC products are not designed for use in life support appliances, devices or systems where malfunction of these products can be reasonably expected to result in personal injury. Reproduction in whole or in part is prohibited without the prior written consent of the copyright owner. The information presented in this document does not form part of any quotation or contract, is believed to be accurate and reliable and may be changed without notice.