

12032 120x120x32MM

General Specifications

- ◆ Material..... Frame: Plastic (UL94V-0)
Impeller: Plastic (UL94V-0)
Lead Wire: UL1007AWG#24 or Equivalent (+) Red, (-) Black
- ◆ Expected Life..... Ball Bearing 70,000hrs (40°C)
- ◆ Temperature Range.... Operating temperature -10°C~70°C (Non-condensing)
Storage temperature -40°C~70°C (Non-condensing)
- ◆ Safety Standards..... UL, TUV, RoHS, CE
- ◆ DC Fan Specials..... RD, FG, PWM, IP56



Specifications

Model	#Bearing Type	Rated Voltage	Operating Voltage	Input Current	Input Power	Speed	Max Air Flow	Max Static Pressure	Noise	Weight		
Part No.	B.S	VDC	VDC	Amp	Watt	RPM	CFM	m ³ /min	Inch-H ₂ O	Pa	dB-A	g
DA12032#12U	B	12	7.0~13.8	2.00	24.00	3500	158.22	4.48	0.51	127.39	50.0	237.0
DA12032#12H	B	12	7.0~13.8	1.00	12.00	3000	134.90	3.82	0.38	95.12	46.0	237.0
DA12032#12M	B	12	7.0~13.8	0.80	9.60	2500	110.90	3.14	0.26	64.92	40.0	237.0
DA12032#12L	B	12	7.0~13.8	0.50	6.00	2000	91.15	2.58	0.18	45.60	33.0	237.0
DA12032#24U	B	24	14.0~27.6	1.00	24.00	3500	158.22	4.48	0.51	127.39	50.0	237.0
DA12032#24H	B	24	14.0~27.6	0.70	16.80	3000	134.90	3.82	0.38	95.12	46.0	237.0
DA12032#24M	B	24	14.0~27.6	0.50	12.00	2500	110.90	3.14	0.26	64.92	40.0	237.0
DA12032#24L	B	24	14.0~27.6	0.30	7.20	2000	91.15	2.58	0.18	45.60	33.0	237.0
DA12032#48U	B	48	28.0~56.0	0.60	28.80	3500	158.22	4.48	0.51	127.39	50.0	237.0
DA12032#48H	B	48	28.0~56.0	0.45	21.60	3000	134.90	3.82	0.38	95.12	46.0	237.0
DA12032#48M	B	48	28.0~56.0	0.25	12.00	2500	110.90	3.14	0.26	64.92	40.0	237.0
DA12032#48L	B	48	28.0~56.0	0.15	7.20	2000	91.15	2.58	0.18	45.60	33.0	237.0

Specifications are subject to change without notice. Please visit our website at <http://www.szhxht.com> for update information

Dimensions (Unit:mm)

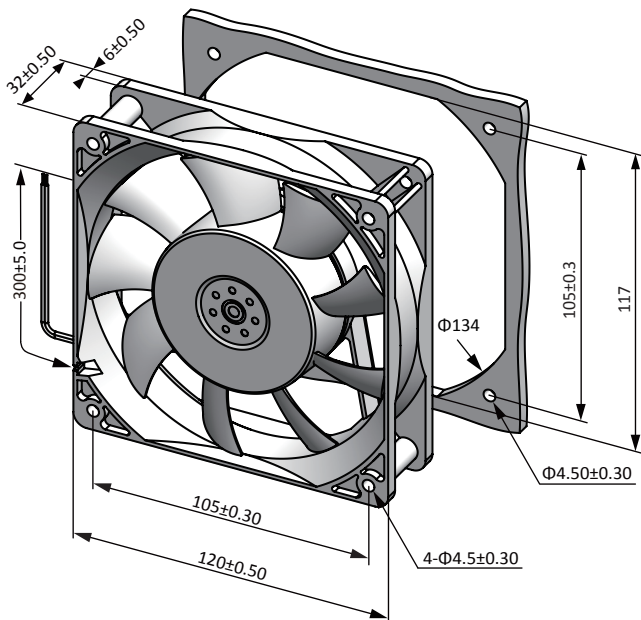

PQ Curve (At rated Voltage)

