

L-KLS7-SS-12F20A-G5

Rating:  
0.5A 50V DC

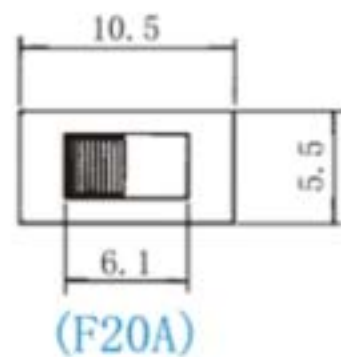

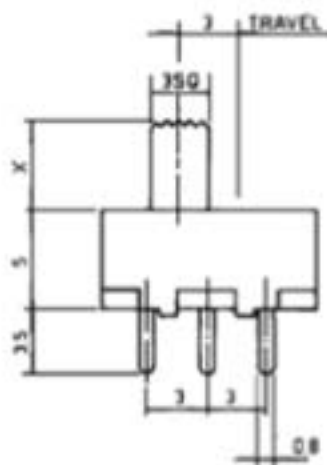
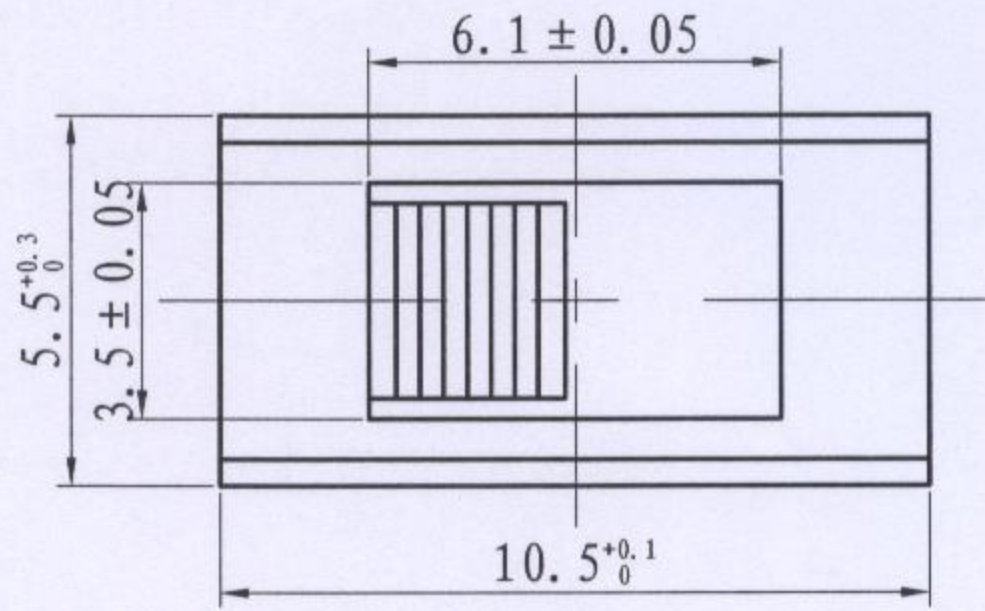

Operating Parameters	
Rated Parameters	0.5A 50V DC
Electrical Life	10000次
Mechanical Life	20000次
Environment Temp.	-25 ~ 85°C
Insulation Resistance	≥ 100MΩ
Contact Resistance	≤ 30mΩ
Operating Force	200 ~ 250 GF
Withstand voltage	500V AC/min

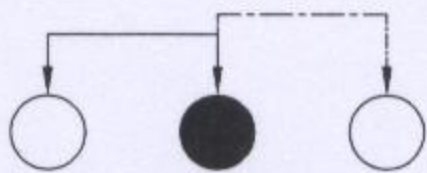
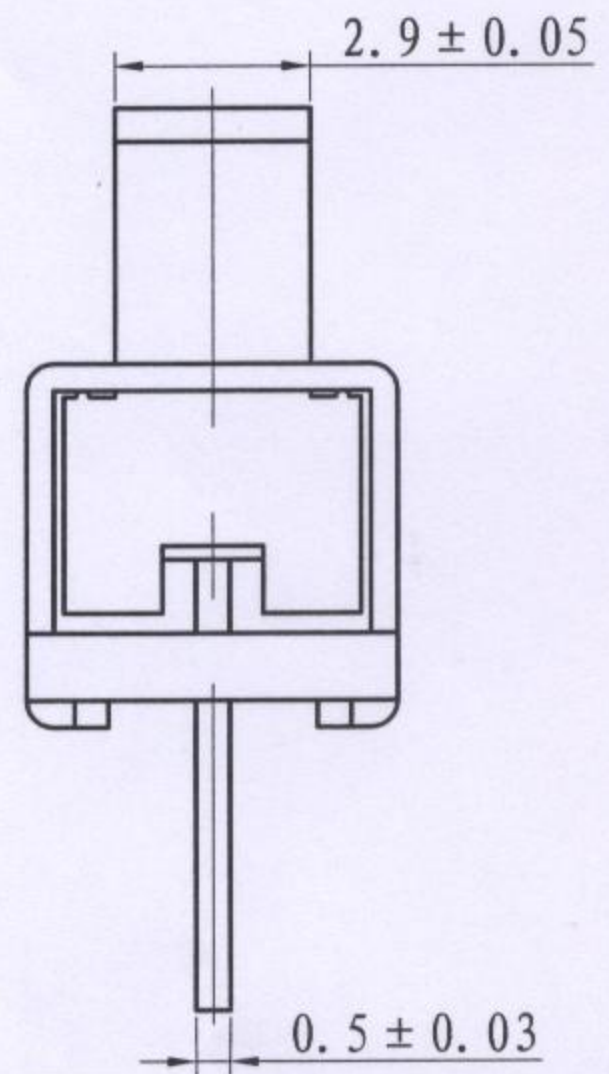
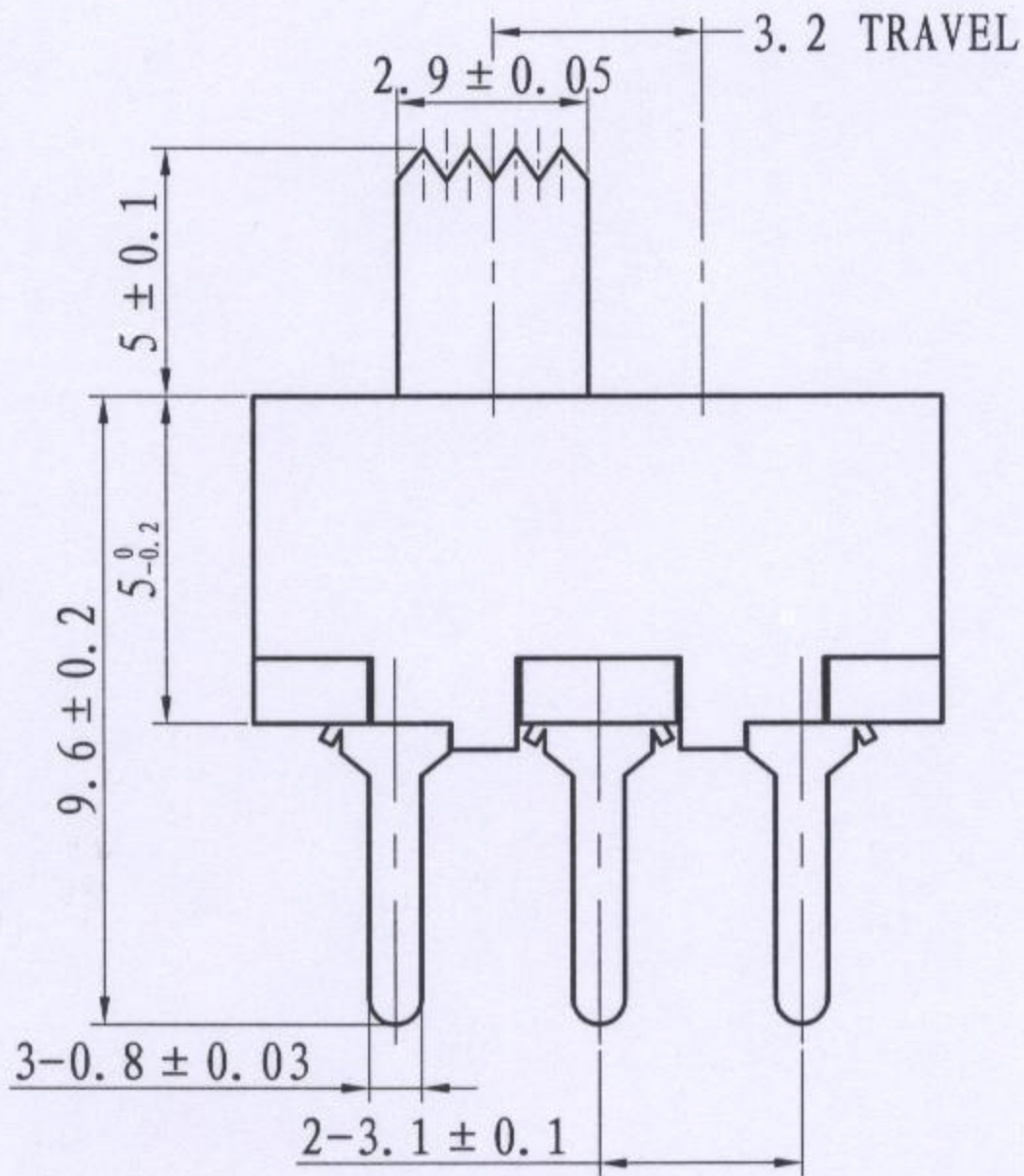

Electrical Schematic Diagram

Plating coating					
				Slide Switch	
				L-KLS7-SS-12F20A-G5	
Projection	Version	Weight	Ratio	KLS ELECTRONIC CO., LTD	
	A0				
Page 1	Total 1				