



产品承认书

SPECIFICATION FOR APPROVAL

CUSTOMER : Ozdisan
CUSTOMER P/N :
SAMPLE NO. :
MODEL NO. : DA06020B24H
DESCRIPTION : 60×60×20mm
ISSUE DATE : 2015-09-21



客户确认签名 / CUSTOMER'S AUTHORIZED SIGNATURE:

签名/SIGNATURE

时间/TIME

感谢您选择我公司产品，如果确认符合贵司要求，劳烦将首页签章回传到我公司。
Thanks for your interest in our products. Please sign and return this page to us after confirming your approval.

SHENZHEN HUAXIA HENGTAI ELECTRONIC CO.,LTD.
NO.14 LINGWU INDUSTRIAL AREA JUNZIBU GUANLAN STREET BAO'AN DISTRICT
SHENZHEN GUANGDONG CHINA
TEL:86-755-27996118 FAX:86-755-27189911
URL:WWW.HXHT.NET & WWW.SZHXHT.COM

DRAWN.BY	CHECKED.BY ENG	APPROVED.BY VM	

参数规格(PRODUCT SPECIFICATION)

A. 一般规格(General Specification)

项目/ITEM		规格.条件/Specification Condition	
01	型 号 / Part No.	DA06020B24H	
02	外型尺寸 / Dimension	60×60×20mm	
03	额定电压 / Rated Voltage	24VDC	
04	启动电压 / Start-up Voltage	12VDC	25°C/switching power ON/OFF
05	操作电压 / Operating Voltage	14.0~27.6VDC	
06	额定转速 / Rated Speed	4500rpm	±10% a. 额定电压 / Rated Voltage b. 25°C c. 65% RH d. Measured after 5 Mins
07	额定电流 / Rated Current	0.08A	
08	额定功率 / Rated Power	1.92W	
09	安规电流/ Safety Current	0.14A The current is for Safety Regulation.	
10	最大风量 / Max Airflow	21.40	CFM
		0.61	m ³ /min
11	最大静压 / Max Static Pressure	0.20	Inch-H ₂ O
		5.08	mm-H ₂ O
12	寿命预估 / Life Expectancy	50000hrs at 40°C a.L10 at Conf. Level 90% b.额定电压 / Rated Voltage	
13	噪音测试/Noise Level	31dB a.额定电压/Rated Voltage b.无响室/Non-Echo Chamber c.标准/Standard:CNS 8753/ISO3744 d.Test Condition:ISO 7779 e.距离/Distance: 1.0M	
14	马达极数/ No. of Pole	4 极/Poles	
15	回转方向/ Rotating Direction	顺时针/Clockwise (从标签面看/From Label side)	

B. 电气规格(Electrical Specification)

项目/ITEM		规格.条件/Specification. Condition	
01	锁定扇叶保护功能 Locked Rotor Protection	<input checked="" type="checkbox"/>	安规条件/ Safety Condition
		<input type="checkbox"/>	额定电压锁住扇叶 1 秒, 自动断电, 自动断电后, 2~6 秒后尝试重新启动/Auto power off after locked at rated voltage for 1sec After auto power off ,circuit attempt restart in 2 to 6sec
02	极性保护 Polarity Protection	<input type="checkbox"/>	Vcc 与 GND 反接时, 不导通 Open circuit when Vcc&GND are exchanged
		<input checked="" type="checkbox"/>	Vcc 与 GND 反接时, 5 秒内不烧毁/Circuit won't be burned within 5 seconds when Vcc &GND are exchanged
03	绝缘阻抗 Insulation Resistance	10MΩ 裸线与外框间测量, 500VDC/min 10MΩ Between unshielded wire and frame at 500VDC/min	
04	绝缘耐压 Dielectric Strength	5mA Max/ 裸线与外框间测量, 500VAC/min 5mA Max/ Measured b/w lead wire(+)and frame at 500VAC/min	
05	特殊功能 Special Function	<input type="checkbox"/> 软启动/Soft StartS	<input type="checkbox"/> 限流 /Current Limiter



C.主要材料,零件规格(Main Materials, Parts Specification)

01	轴 承/Bearing	<input checked="" type="checkbox"/> 双滚珠轴承 (Dual Ball Bearing)	<input type="checkbox"/> 含油轴承 (Sleeve Bearing)		
02	外框材质/Frame	<input checked="" type="checkbox"/> PBT of UL94V-0.	<input type="checkbox"/> Die-cast Aluminum Alloy		
03	扇叶材质/Impeller	<input checked="" type="checkbox"/> PBT of UL94V-0.	<input type="checkbox"/> Steel		
04	绝缘套/Bobbin	<input checked="" type="checkbox"/> PBT of UL94V-0.			
05	导线/Lead Wire	<input checked="" type="checkbox"/> Red(+)	<input checked="" type="checkbox"/> Black(-)	<input type="checkbox"/> Blue (PWM)	UL1007 24#
		<input type="checkbox"/> Yellow(FG)	<input type="checkbox"/> White(RD)	2 wires 300±10mm	
06	端子/Connector	无/No			
07	套管/Tube	无/No			

D.环境测试/Environmental Specification

项目/ITEM		规格.条件/Specification. Condition	
01	运转温度、湿度范围 Operating Temp. Range	温度/Temperature	: -10 °C ~70°C
		湿度/Humidity	:15%~ 90% RH (Frost Eliminated)
02	保存温度、湿度范围 Storage Temp. Range	温度/Temperature	: -40 °C ~70°C
		湿度/Humidity	:15%~ 90% RH (Frost Eliminated)

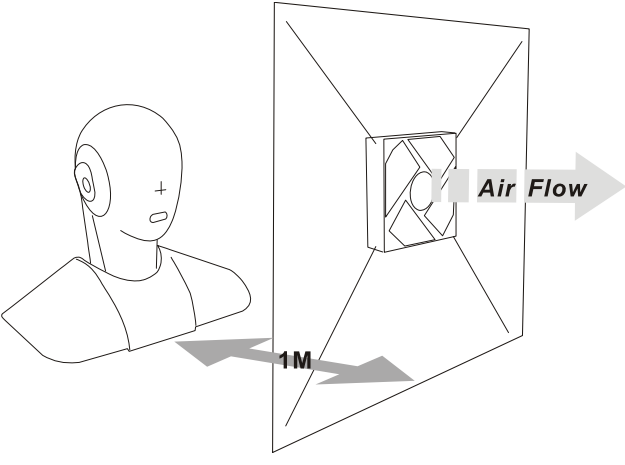
F.噪音测试条件/Noise Measure Condition

	
测量系统/Measurement Systems	
1.ANECHOIC Room Noise Measurement System	
2.Digital Head Measurement System, 16-bit version	
3.Specifications:ISO 3744,ISO 3745,ISO 7779, CNS6753,JIS 8346	
4.Background Noise:<18dB(A)	

G. 商标 (Label Marking)

	型号/Model No.4	DA06020B24H
	额定电压/Rated Voltage	24VDC
	安规电流/Safety Current	0.14A
	标签尺寸/Label Size	Φ29mm
	商标颜色/Label Color	绿色/Green
	安规/Safety Approvals	UL CE TUV
	附加码/Appendix Code	无/No

H. 外框尺寸 (Outline Dimension)

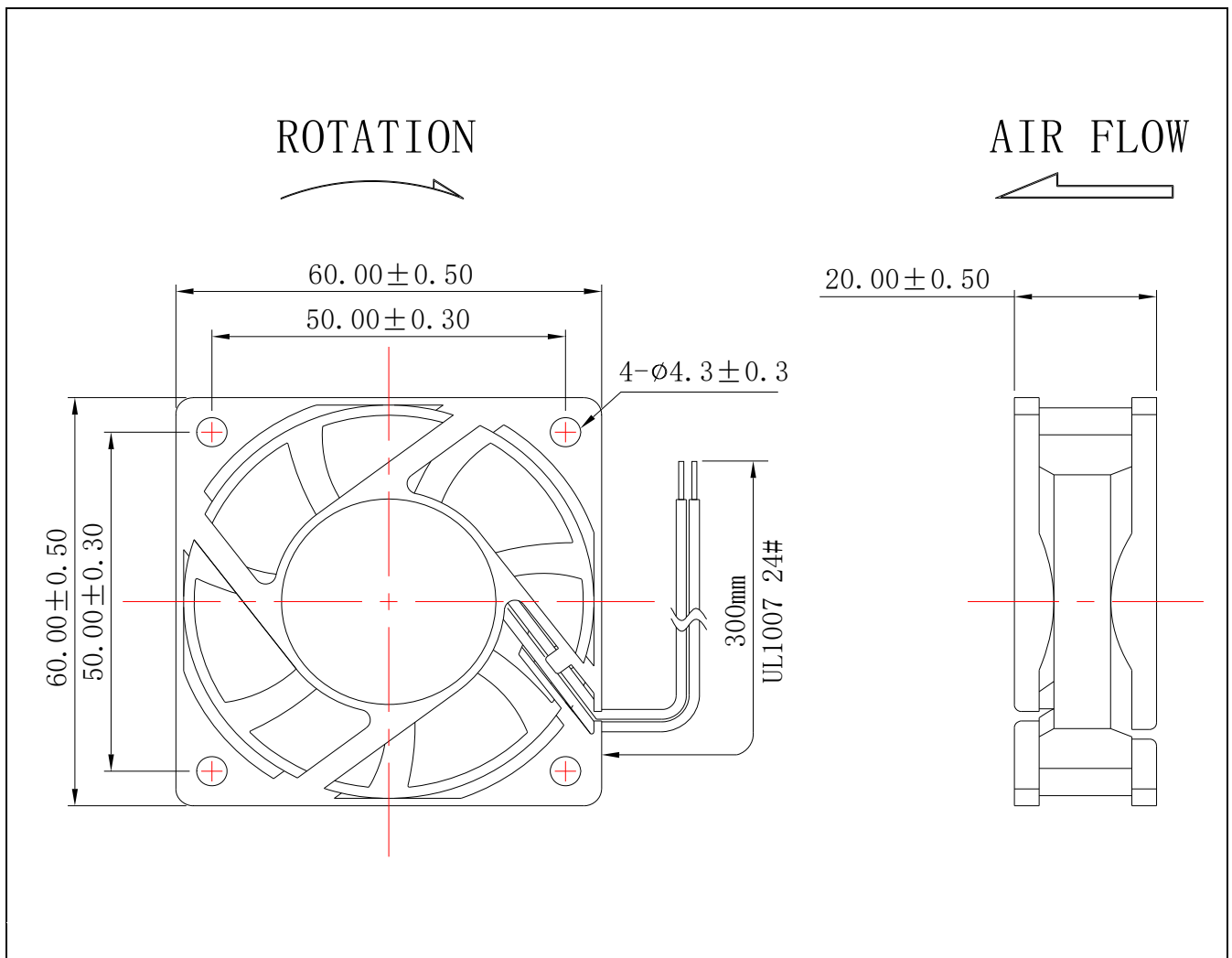

Note:

1. We will not guarantee the products if your application exceeds the limitations outlined in this specification.
2. Please do not touch and push fan blade with fingers or others. Fan blade and ball bearings may be damaged. And it caused noise defect.
3. Please avoid operating YIMENG's products in poisonous material(organic, cyanogens, formalin, phenol, etc.)or corrosive gas environment(H_2S , SO_2 , NO_2 ,etc.)
4. We do not warrant performance safety against accidents caused by dust, water, droplets dew, bugs, etc.
5. Always ensure that fans are stored according to the storage temperatures specified. Do not store in a high humidity environment. If the fans are stored for more than 6 months, we recommend functional testing before using.
6. Please do not damage this product this product including coil and lead wires while installing or wiring. There may be smoking or fire.
7. Avoid the damage, check the correct voltage and proper polarity before connecting with power.
8. Improper mounting may cause harsh resonance, vibration, and noise. Please mount securely.
9. It is very important to notify that avoid to drop from 60cm height when in any movement or operation, it will impact the balance of blade. Especially ball bearing structure is avoided to drop down.
10. Safety is a top priority. Please furnish guard accessories to prevent injury to personnel