

# SGM803 SGM809 SGM810

## Microprocessor Supervisory Circuit in 3-Pin SOT23

### GENERAL DESCRIPTION

The SGM803/SGM809/SGM810 supervisory circuits monitor the power supply voltage in microprocessor and digital systems. They provide a reset output during power-up, power-down and brownout conditions. On power-up, an internal timer holds reset asserted for 240 ms. This holds the microprocessor in a reset state until conditions have stabilized. The  $\overline{\text{RESET}}$  output remains operational with  $V_{CC}$  as low as 1 V. The SGM803/SGM809 provides an active low reset signal ( $\overline{\text{RESET}}$ ) while the SGM810 provides an active high signal (RESET) output. The SGM809/SGM810 has push-pull outputs, whereas the SGM803 has an open-drain output, which requires an external pull-up resistor.

Seven reset threshold voltage options are available suitable for monitoring 2.5V, 3V, 3.3V, and 5V supply voltages.

The reset comparator features built-in glitch immunity, making it immune to fast transients on  $V_{CC}$ .

The low supply current of typically 17 $\mu\text{A}$  makes the SGM803/SGM809/SGM810 ideal for use in portable, battery operated equipment. All are specified over the extended  $-40^{\circ}\text{C}$  to  $+125^{\circ}\text{C}$  temperature range.

### APPLICATIONS

Microprocessor Systems  
Controllers  
Intelligent Instruments  
Automotive Systems  
Safety Systems  
Portable Instruments

### TYPICAL OPERATION CIRCUIT

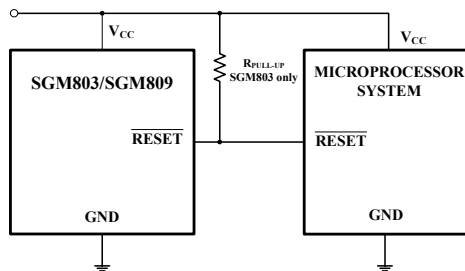

### FEATURES

- Precision Voltage Monitor: 2.5V, 3V, 3.3V, 5V Options
- Superior Upgrade for MAX803/MAX809/MAX810 and ADM803/ADM809/ADM810
- Fully Specified over Temperature
- Low Power Consumption (17 $\mu\text{A}$  TYP)
- Reset Assertion Down to 1V  $V_{CC}$
- 160ms Min Power-On Reset
  - Open-Drain  $\overline{\text{RESET}}$  Output (SGM803)
  - Push-Pull  $\overline{\text{RESET}}$  Output (SGM809)
  - Push-Pull RESET Output (SGM810)
- $-40^{\circ}\text{C}$  to  $+125^{\circ}\text{C}$  Operating Temperature Range
- Small Packaging
  - SGM803 Available in SOT23-3
  - SGM809 Available in SOT23-3 and SOT-23
  - SGM810 Available in SOT23-3

### PIN CONFIGURATIONS (TOP VIEW)

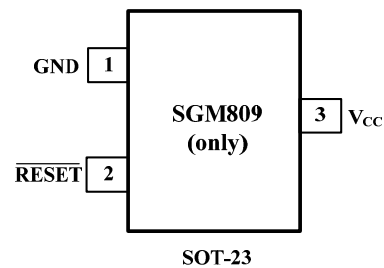
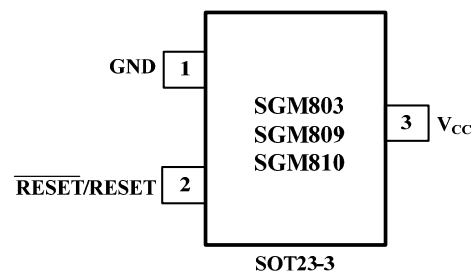

## ORDERING INFORMATION

MODEL	RESET THRESHOLD (V)	PACKAGE DESCRIPTION	ORDERING NUMBER	PACKAGE MARKING	PACKAGE OPTION
SGM803	4.63	SOT23-3	SGM803-LXN3	803L	Tape and Reel, 3000
	4.38	SOT23-3	SGM803-MXN3	803M	Tape and Reel, 3000
	4.00	SOT23-3	SGM803-JXN3	803J	Tape and Reel, 3000
	3.08	SOT23-3	SGM803-TXN3	803T	Tape and Reel, 3000
	2.93	SOT23-3	SGM803-SXN3	803S	Tape and Reel, 3000
	2.63	SOT23-3	SGM803-RXN3	803R	Tape and Reel, 3000
	2.32	SOT23-3	SGM803-ZXN3	803Z	Tape and Reel, 3000
SGM809	4.63	SOT23-3	SGM809-LXN3	809L	Tape and Reel, 3000
	4.63	SOT-23	SGM809-LXN3L	809LL	Tape and Reel, 3000
	4.38	SOT23-3	SGM809-MXN3	809M	Tape and Reel, 3000
	4.38	SOT-23	SGM809-MXN3L	809ML	Tape and Reel, 3000
	4.00	SOT23-3	SGM809-JXN3	809J	Tape and Reel, 3000
	4.00	SOT-23	SGM809-JXN3L	809JL	Tape and Reel, 3000
	3.08	SOT23-3	SGM809-TXN3	809T	Tape and Reel, 3000
	3.08	SOT-23	SGM809-TXN3L	809TL	Tape and Reel, 3000
	2.93	SOT23-3	SGM809-SXN3	809S	Tape and Reel, 3000
	2.93	SOT-23	SGM809-SXN3L	809SL	Tape and Reel, 3000
	2.63	SOT23-3	SGM809-RXN3	809R	Tape and Reel, 3000
	2.63	SOT-23	SGM809-RXN3L	809RL	Tape and Reel, 3000
	2.32	SOT23-3	SGM809-ZXN3	809Z	Tape and Reel, 3000
	2.32	SOT-23	SGM809-ZXN3L	809ZL	Tape and Reel, 3000
	SGM810	4.63	SOT23-3	SGM810-LXN3	810L
4.38		SOT23-3	SGM810-MXN3	810M	Tape and Reel, 3000
4.00		SOT23-3	SGM810-JXN3	810J	Tape and Reel, 3000
3.08		SOT23-3	SGM810-TXN3	810T	Tape and Reel, 3000
2.93		SOT23-3	SGM810-SXN3	810S	Tape and Reel, 3000
2.63		SOT23-3	SGM810-RXN3	810R	Tape and Reel, 3000
2.32		SOT23-3	SGM810-ZXN3	810Z	Tape and Reel, 3000

## ABSOLUTE MAXIMUM RATINGS

(Typical values are at  $T_A = 25^\circ\text{C}$ , unless otherwise noted.)

$V_{CC}$ .....	-0.3V to +6V
RESET, $\overline{\text{RESET}}$ .....	-0.3V to $V_{CC} + 0.3\text{V}$
Input Current, $V_{CC}$ .....	20mA
Output Current, RESET, $\overline{\text{RESET}}$ .....	20mA
Rate of Rise, $V_{CC}$ .....	100V/ $\mu\text{s}$
Power Dissipation, $P_D$ @ $T_A = 25^\circ\text{C}$	
SOT23-3.....	0.4W
Package Thermal Resistance	

SOT23-3, $\theta_{JA}$ .....	250 $^\circ\text{C}/\text{W}$
Operating Temperature Range.....	- 40 $^\circ\text{C}$ to +125 $^\circ\text{C}$
Junction Temperature.....	+150 $^\circ\text{C}$
Storage Temperature.....	- 65 $^\circ\text{C}$ to +150 $^\circ\text{C}$
Lead Temperature (soldering, 10s).....	+260 $^\circ\text{C}$
ESD Susceptibility	
HBM.....	4000V
MM.....	400V

Stresses beyond those listed under “Absolute Maximum Ratings” may cause permanent damage to the device. These are stress ratings only, and functional operation of the device at these or any other conditions beyond those indicated in the operational sections of the specifications is not implied. Exposure to absolute maximum rating conditions for extended periods may affect device reliability.

## PIN DESCRIPTION

NAME	Pin Number			FUNCTION
	SGM803	SGM809	SGM810	
GND	1	1	1	Ground
$\overline{\text{RESET}}$	2	2	—	Active Low reset. $\overline{\text{RESET}}$ remains low while $V_{CC}$ is below the reset threshold, and remains low for 240ms (TYP) after $V_{CC}$ rises above the reset threshold.
RESET	—	—	2	Active High reset. RESET remains high while $V_{CC}$ is below the reset threshold, and remains high for 240ms (TYP) after $V_{CC}$ rises above the reset threshold.
$V_{CC}$	3	3	3	Power supply voltage that is monitored.

## ELECTRICAL CHARACTERISTICS

(V<sub>CC</sub> Typ = 5V for L/M/J Models, 3.3V for T/S Models, 3V for R Models, 2.5V for Z Models; unless otherwise noted.)

PARAMETER	CONDITIONS	MIN	TYP	MAX	UNITS
<b>SUPPLY</b>					
Voltage	T <sub>A</sub> = 0°C to 70°C	1.0		5.5	V
	T <sub>A</sub> = -40°C to +125°C	1.2		5.5	V
Current	V <sub>CC</sub> < 5.5 V, SGM8_L/M/J, T <sub>A</sub> = 25°C		20	30	μA
	V <sub>CC</sub> < 5.5 V, SGM8_L/M/J, T <sub>A</sub> = -40°C to +125°C			50	μA
	V <sub>CC</sub> < 3.6 V, SGM8_R/S/T/Z, T <sub>A</sub> = 25°C		17	25	μA
	V <sub>CC</sub> < 3.6 V, SGM8_R/S/T/Z, T <sub>A</sub> = -40°C to +125°C			45	μA
<b>RESET VOLTAGE THRESHOLD</b>					
SGM8_L	T <sub>A</sub> = 25°C	4.537	4.63	4.723	V
	T <sub>A</sub> = -40°C to +125°C	4.40		4.86	V
SGM8_M	T <sub>A</sub> = 25°C	4.292	4.38	4.468	V
	T <sub>A</sub> = -40°C to +125°C	4.16		4.56	V
SGM8_J	T <sub>A</sub> = 25°C	3.92	4.00	4.08	V
	T <sub>A</sub> = -40°C to +125°C	3.8		4.2	V
SGM8_T	T <sub>A</sub> = 25°C	3.003	3.08	3.157	V
	T <sub>A</sub> = -40°C to +125°C	2.92		3.23	V
SGM8_S	T <sub>A</sub> = 25°C	2.857	2.93	3.003	V
	T <sub>A</sub> = -40°C to +125°C	2.78		3.08	V
SGM8_R	T <sub>A</sub> = 25°C	2.564	2.63	2.696	V
	T <sub>A</sub> = -40°C to +125°C	2.50		2.76	V
SGM8_Z	T <sub>A</sub> = 25°C	2.262	2.32	2.378	V
	T <sub>A</sub> = -40°C to +125°C	2.22		2.42	V
Reset Threshold Temperature Coefficient			30		ppm/°C
V <sub>CC</sub> to RESET/ $\overline{\text{RESET}}$ Delay	V <sub>CC</sub> = V <sub>TH</sub> to (V <sub>TH</sub> -100 mV)		20		μs
Reset Active Timeout Period	T <sub>A</sub> = -40°C to +85°C	160	240	560	ms
	T <sub>A</sub> = -40°C to +125°C	100		840	ms
<b>RESET/<math>\overline{\text{RESET}}</math> OUTPUT VOLTAGE</b>					
Low (SGM803R/S/T/Z) Low (SGM809R/S/T/Z)	V <sub>CC</sub> = V <sub>TH(MIN)</sub> , I <sub>SINK</sub> = 1.2mA			0.3	V
Low (SGM803L/M/J) Low (SGM809L/M/J)	V <sub>CC</sub> = V <sub>TH(MIN)</sub> , I <sub>SINK</sub> = 3.2mA			0.4	V
Low (SGM803R/S/T/L/M/J/Z) Low (SGM809R/S/T/L/M/J/Z)	V <sub>CC</sub> > 1.0 V, I <sub>SINK</sub> = 50μA			0.3	V
High (SGM809R/S/T/Z)	V <sub>CC</sub> > V <sub>TH(MAX)</sub> , I <sub>SOURCE</sub> = 500μA	0.8×V <sub>CC</sub>			V
High (SGM809L/M/J)	V <sub>CC</sub> > V <sub>TH(MAX)</sub> , I <sub>SOURCE</sub> = 800μA	V <sub>CC</sub> -1.5			V
Low (SGM810R/S/T/Z)	V <sub>CC</sub> = V <sub>TH(MAX)</sub> , I <sub>SINK</sub> = 1.2mA			0.3	V
Low (SGM810L/M/J)	V <sub>CC</sub> = V <sub>TH(MAX)</sub> , I <sub>SINK</sub> = 3.2mA			0.4	V
High (SGM810 R/S/T/L/M/J)	1.8 V < V <sub>CC</sub> < V <sub>TH(MIN)</sub> , I <sub>SOURCE</sub> = 150μA	0.8×V <sub>CC</sub>			V
$\overline{\text{RESET}}$ Open-Drain Output Leakage Current (SGM803)	V <sub>CC</sub> > V <sub>TH</sub> , reset de-asserted			1	μA

Specifications subject to changes without notice.

# TYPICAL PERFORMANCE CHARACTERISTICS

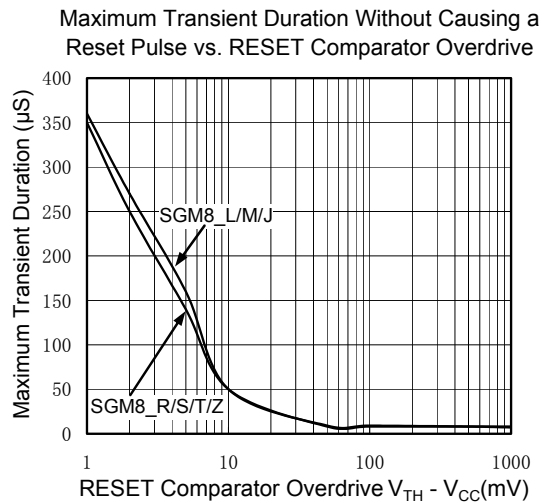
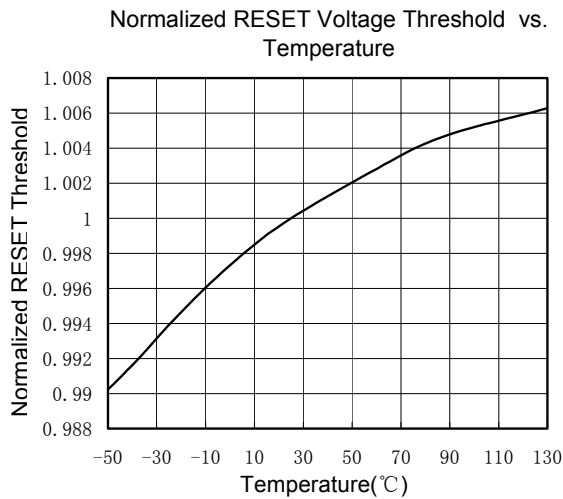
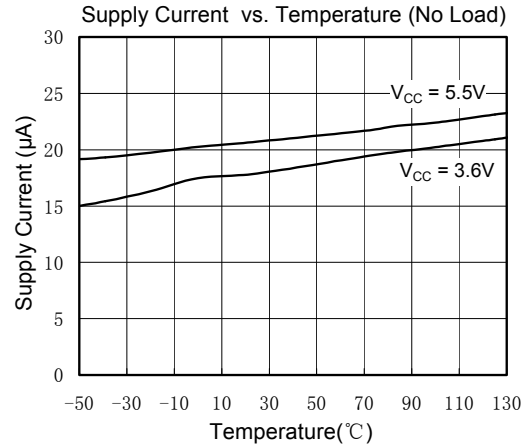
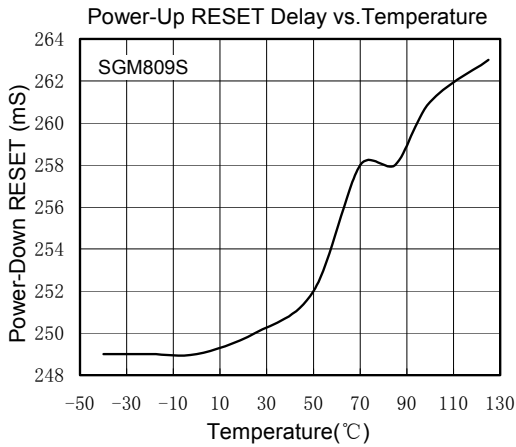
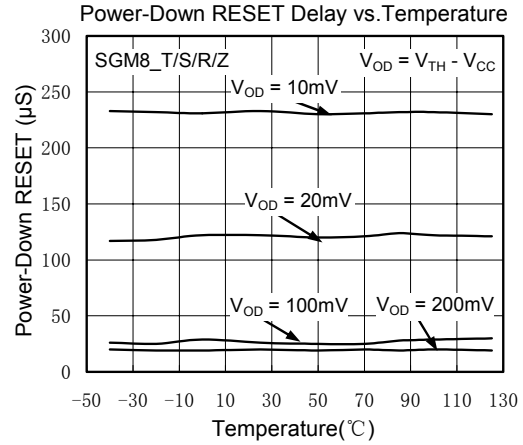
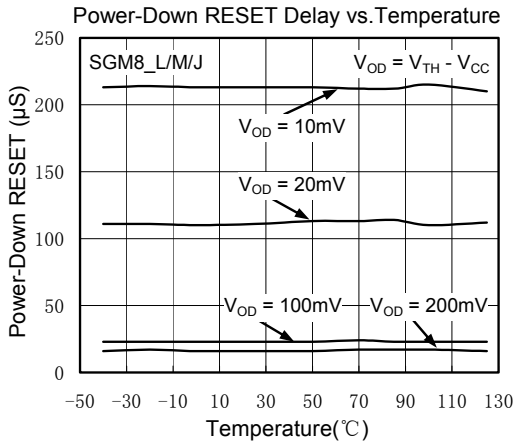

# TYPICAL PERFORMANCE CHARACTERISTICS

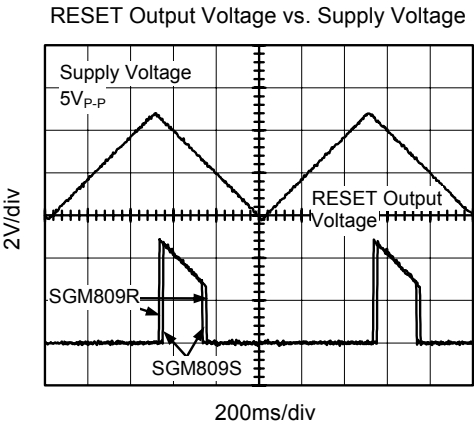

# APPLICATION NOTES

## BENEFITS OF AN ACCURATE RESET THRESHOLD

In other microprocessor supervisory circuits, tolerances in supply voltages lead to an overall increase in reset tolerance levels due to the deterioration of the microprocessor reset circuit's power supply. The possibility of a malfunction during a power failure is greatly reduced because the SGM803/SGM809/SGM810 series can operate effectively even when there are large degradations of the supply voltages. Another advantage of the SGM803/SGM809/SGM810 series is its very accurate internal voltage reference circuit. These benefits combine to produce an exceptionally reliable voltage monitor circuit.

## INTERFACING TO MICROPROCESSORS WITH MULTIPLE INTERRUPTS

In a number of cases, it is necessary to interface many interrupts from different devices (for example, thermal, altitude, and velocity sensors). The SGM803/SGM809/SGM810 can easily be integrated into existing interrupt-handling circuits, as shown in Figure 1, or can be used as a standalone device.

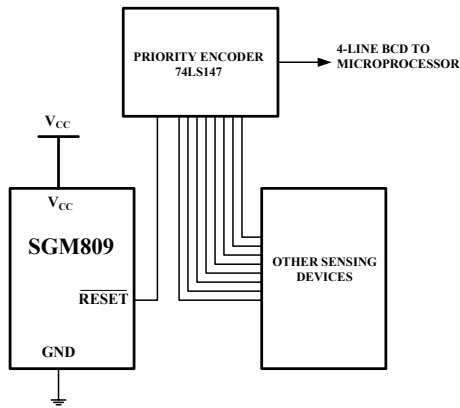

Figure 1. Interfacing to Microprocessors with Multiple Interrupts

## INTERFACING TO OTHER DEVICES' OUTPUT

The SGM803/SGM809/SGM810 series is designed to integrate with as many devices as possible and, therefore, has a standard output dependent on  $V_{CC}$ . This enables the parts to be used in both 3 V and 5 V, or any nominal voltage within the minimum and maximum specifications for  $V_{CC}$ . This design simplifies interfacing this device to other devices.

## ENSURING A VALID RESET OUTPUT DOWN TO $V_{CC} = 0\text{ V}$

When  $V_{CC}$  falls below 1.0 V, the SGM803/SGM809  $\overline{RESET}$  no longer sinks current. A high impedance CMOS logic input connected to  $\overline{RESET}$  may, therefore, drift to undetermined logic levels. To eliminate this problem, a  $100\text{k}\Omega$  resistor should be connected from  $\overline{RESET}$  to ground.

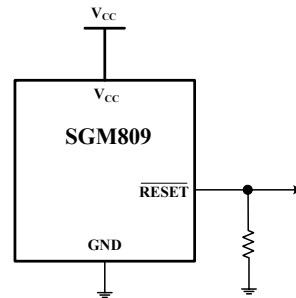
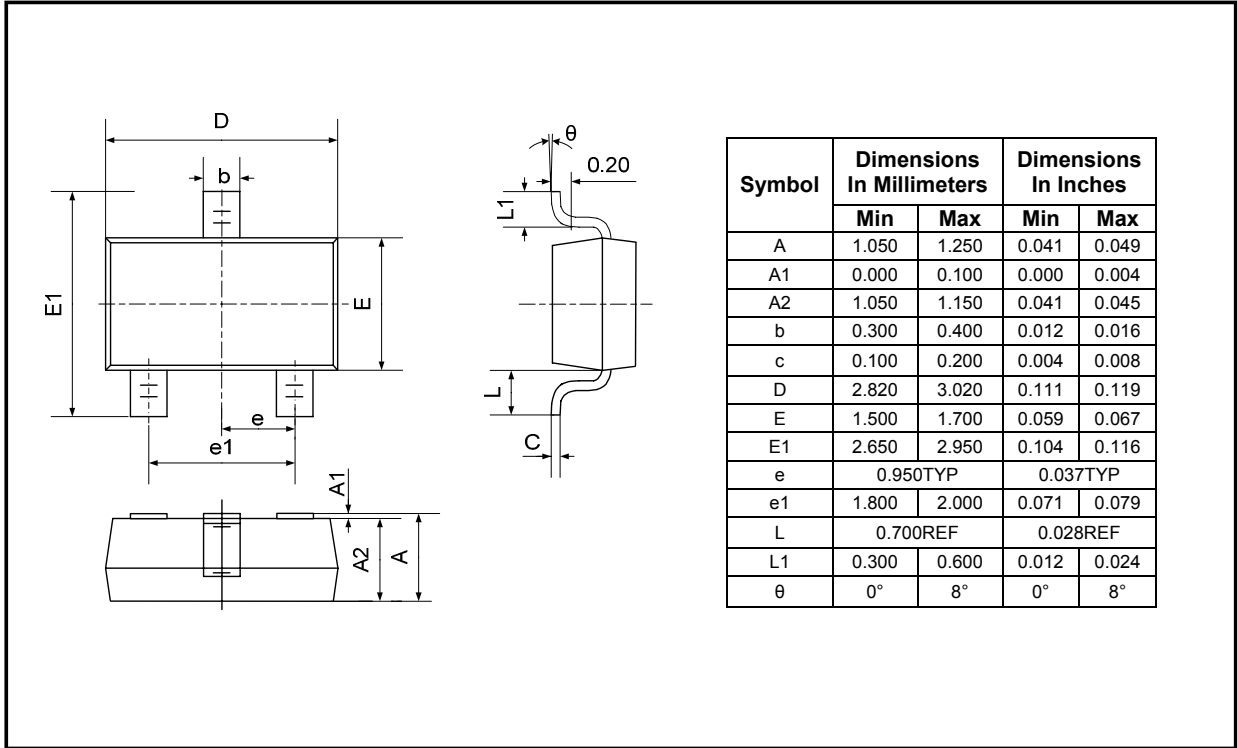

Figure 2. Ensuring a Valid Reset Output Down to  $V_{CC} = 0\text{ V}$

# PACKAGE OUTLINE DIMENSIONS

## SOT23-3





# PACKAGE OUTLINE DIMENSIONS

## SOT-23

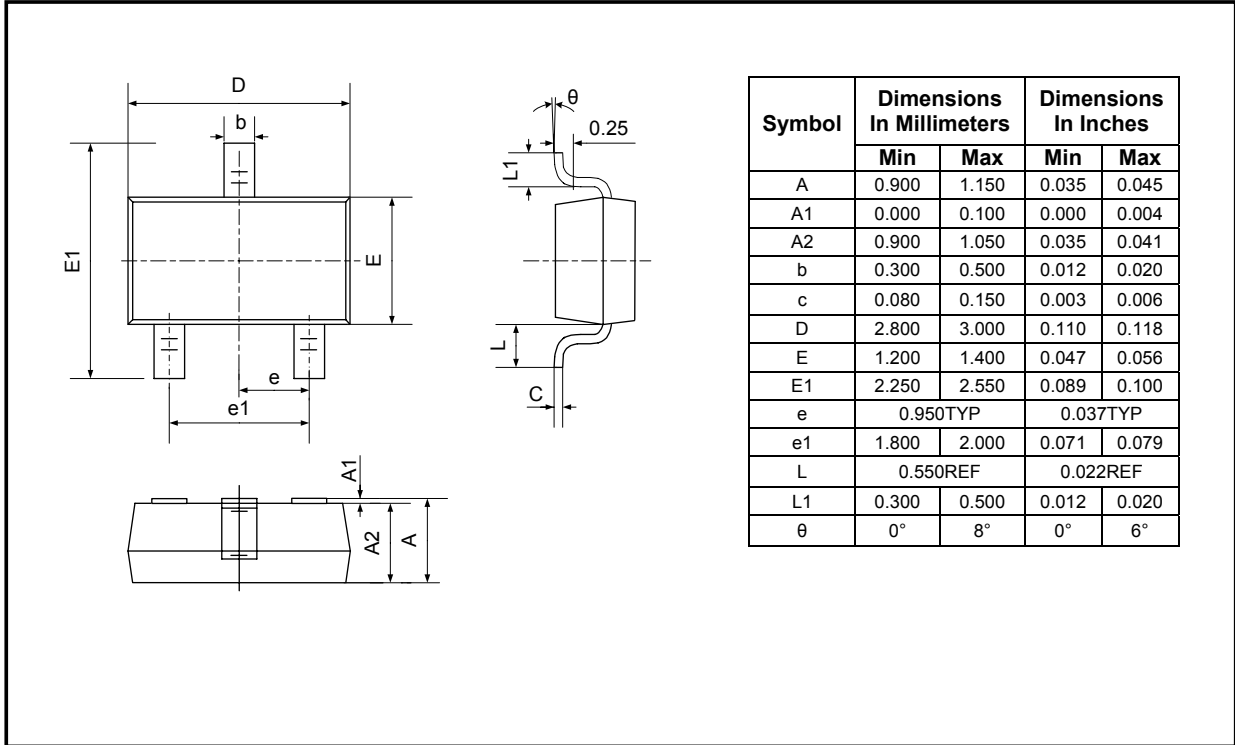

# REVISION HISTORY

Location	Page
11/2006— Data Sheet changed from REV. A to REV. B Changes to ABSOLUTE MAXIMUM RATINGS .....	3
06/2008— Data Sheet changed from REV. B to REV. B. 1 Added SGM803J .....	2, 4
08/2008— Data Sheet changed from REV. B. 1 to REV. C Added SGM809's SOT-23 Package .....	1, 2, 9

## SGMICRO

---

SGMICRO is dedicated to provide high quality and high performance analog IC products to customers. All SGMICRO products meet the highest industry standards with strict and comprehensive test and quality control systems to achieve world-class consistency and reliability.

For information regarding SGMICRO Corporation and its products, see [www.sg-micro.com](http://www.sg-micro.com)