

XIAMEN PRECISE DISPLAY

SPECIFICATIONS FOR LIQUID CRYSTAL DISPLAY

PART NUMBER:

PCM1602B-FL-YBS-03

DATE:

2008.03.16

1.0 MECHANICAL SPECS

1. Overall Module Size	84.0mm(W) x 44.0mm(H) x max 13.0mm(D) for LED backlight version
2. Dot Size	0.56mm(W) x 0.61mm(H)
3. Dot Pitch	0.61mm(W) x 0.66mm(H)
4. Duty	1/16
5. Controller IC	ST7066U or Equivalent
6. LC Fluid Options	STN
7. Polarizer Options	Yellow-Green and Transflective
8. Viewing Angle	6:00 o'clock
9. Backlight Options	LED(Yellow-Green), Vbk=5.0V
10. Temperature Range Options	Operating: -20°C ~ 70°C, Storage: -30°C ~ 80°C

2.0 ABSOLUTE MAXIMUM RATINGS

Item	Symbol	Min	Typ	Max	Unit
Operating temperature (Wide temperature)	Top	-20	-	70	°C
Storage temperature (Wide temperature)	Tst	-30	-	80	°C
Input voltage	Vin	Vss		Vdd	V
Supply voltage for logic	Vdd- Vss	4.5	5.0	5.5	V
Supply voltage for LCD drive	Vdd- Vo	4.2	4.5	4.7	V

3.0 ELECTRICAL CHARACTERISTICS

Item	Symbol	Condition	Min	Typ	Max	Unit
Power Supply Voltage	Vdd	fosc=270kHz	4.5	5.0	5.5	V
Power Supply Current	Idd	Vdd=5.0V, fosc=270kHz	-	0.8	1.8	mA
Recommended LC Driving Voltage (Standard Temp)	Vdd - Vo	0°C	-	4.8	5.4	V
		25°C	4.2	4.5	-	
		50°C	3.9	4.3	-	
Recommended LC Driving Voltage (Wide Temp)	Vdd -Vo	-20°C	-	6.4	7.2	V
		0°C	-	4.8	-	
		50°C	-	4.2	-	
		70°C	3.5	4.0	-	
BackLight Supply Voltage	Vf	R=0Ω	-	5.0	5.5	V
BackLight Supply Current	If	R=0Ω	-	120	-	mA

4.0 OPTICAL CHARACTERISTICS (Ta=25°C, Vdd= 5.0V±0.25V, STN LC fluid)

Item	Symbol	Condition	Min	Typ	Max	Unit
Viewing angle (horizontal)	θ	Cr ≥ 2.0	-60	-	35	deg
Viewing angle (vertical)	φ	Cr ≥ 2.0	-40	-	40	deg
Contrast Ratio	Cr	φ=0°, θ=0°	-	6	-	
Response time (rise)	Tr	φ=0°, θ=0°	-	150	250	ms
Response time (fall)	Tf	φ=0°, θ=0°	-	150	250	ms

5.0 BLOCK DIAGRAM

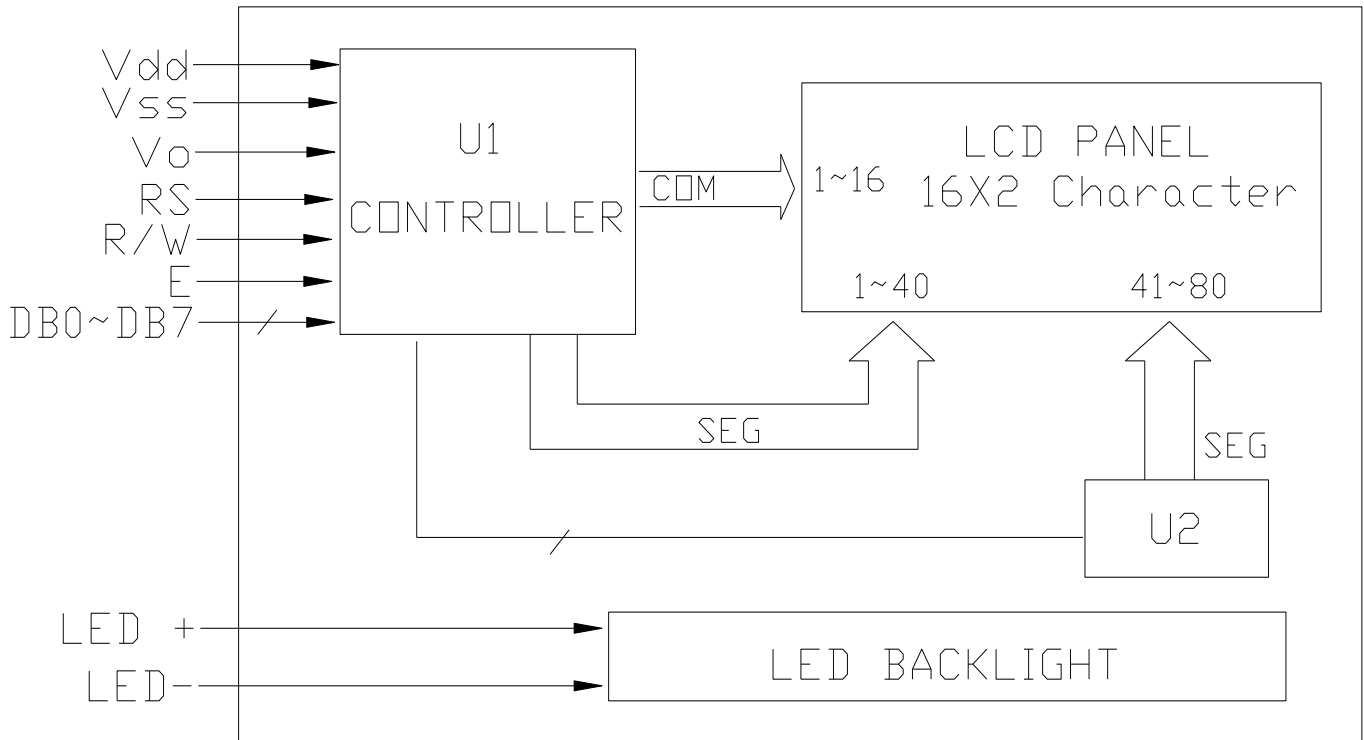

6.0 PIN ASSIGNMENT

Pin No.	Symbol	Function
1	Vss	Ground
2	Vdd	+5.0V
3	Vo	LCD contrast adjust
4	RS	Register select
5	R/W	Read / write
6	E	Enable
7	DB0	Data bit 0
8	DB1	Data bit 1
9	DB2	Data bit 2
10	DB3	Data bit 3
11	DB4	Data bit 4
12	DB5	Data bit 5
13	DB6	Data bit 6
14	DB7	Data bit 7
15	A	Power Supply for + 5.0V
16	K	Power Supply for -

7.0 POWER SUPPLY

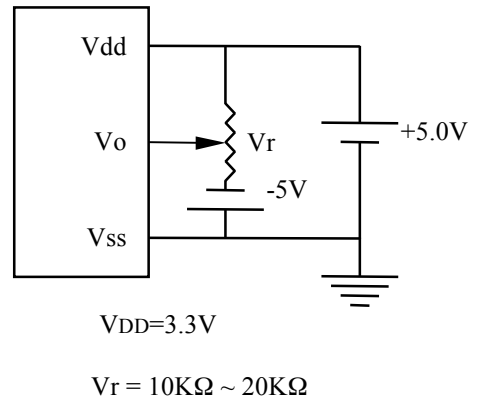
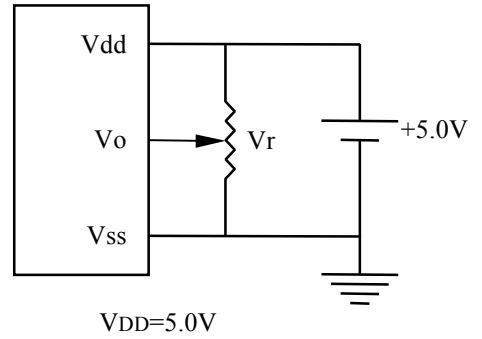

8.0 TIMING CHARACTERISTICS

Item	Symbol	Test Condition	Min.	Typ.	Max.	Unit
Enable cycle time	t _c	Fig. a, Fig. b	500	-	-	ns
Enable pulse width	t _w	Fig. a, Fig. b	220	-	-	ns
Enable rise/fall time	t _r , t _f	Fig. a, Fig. b	-	-	25	ns
RS, R/W set up time	t _{su}	Fig. a, Fig. b	40	-	-	ns
RS, R/W hold time	t _h	Fig. a, Fig. b	10	-	-	ns
Data delay time	t _d	Fig. b	-	-	120	ns
Data set up time	t _{dsu}	Fig. a	60	-	-	ns
Data hold time	t _{dH}	Fig. a, Fig. b	20	-	-	ns

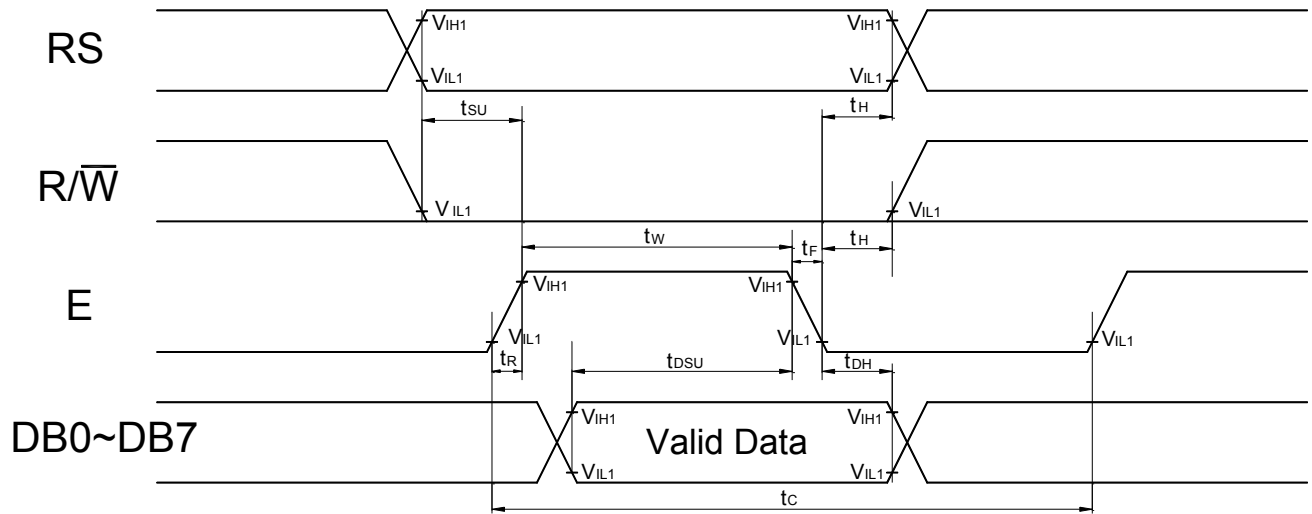

Fig. a Interface timing (data write)

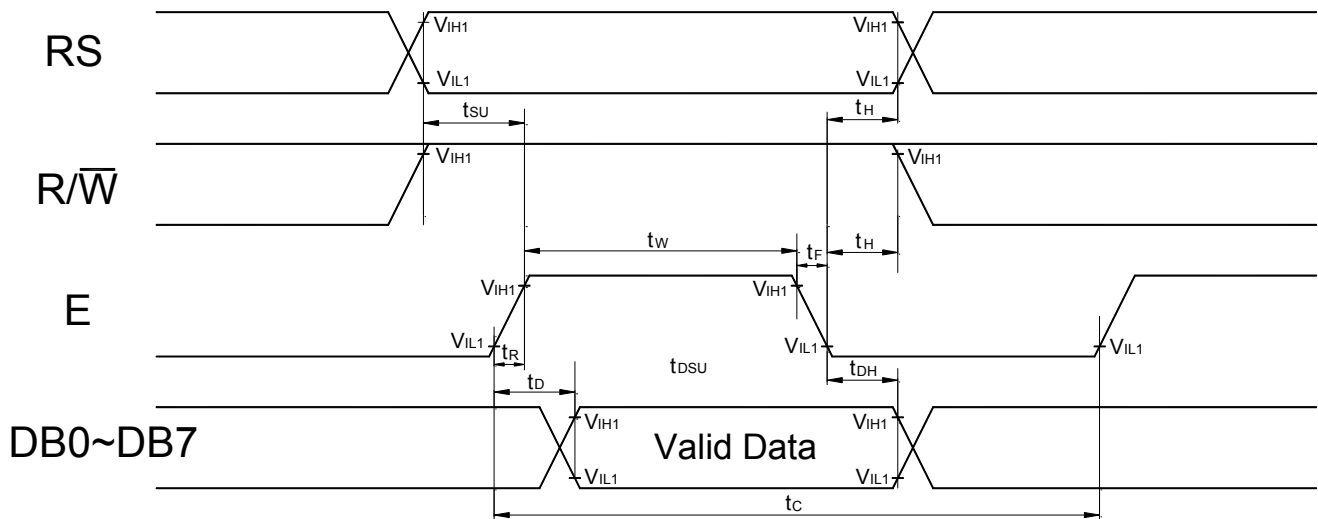
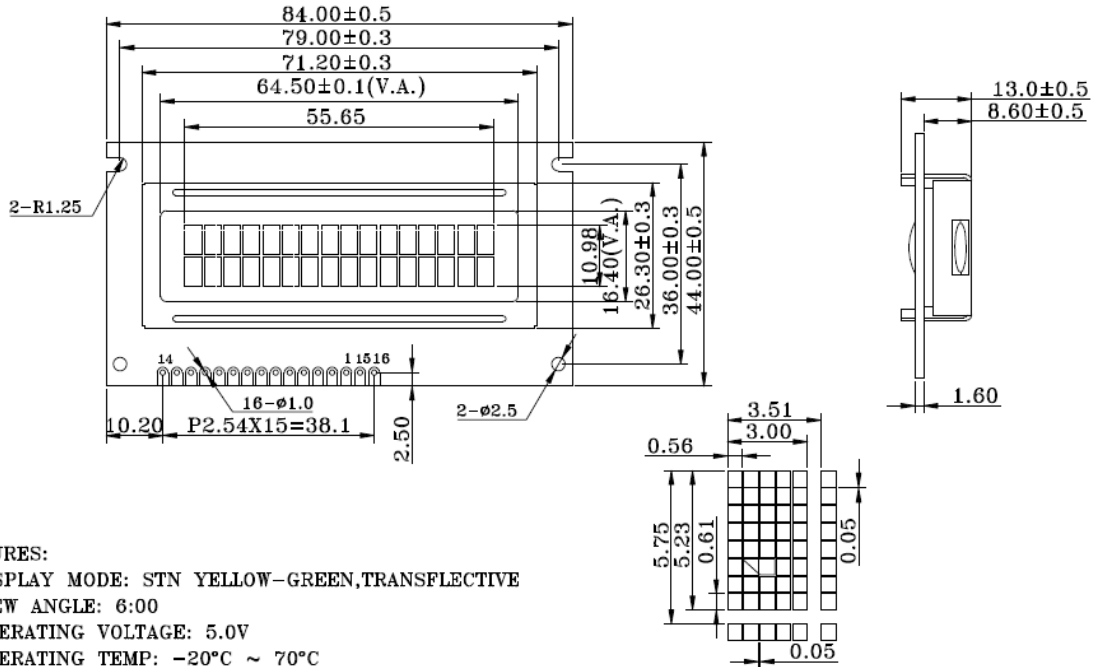

Fig. b Interface timing (data read)

9.0 MECHANICAL DIAGRAM



FEATURES:

1. DISPLAY MODE: STN YELLOW-GREEN, TRANSFLECTIVE
2. VIEW ANGLE: 6:00
3. OPERATING VOLTAGE: 5.0V
4. OPERATING TEMP: -20°C ~ 70°C
5. STORAGE TEMP: -30°C ~ 80°C
6. BACKLIGHT: LED (YELLOW-GREEN), Vbk=5.0V
7. DRIVER: ST7066U-0A OR EQUIVALENT

CENTER OF BZL

TOLERANCES UNLESS OTHERWISE SPECIFIED ±0.2

PIN	1	2	3	4	5	6	7	8
SIGNAL	VSS	VDD	V0	RS	R/W	E	DB0	DB1
PIN	9	10	11	12	13	14	15	16
SIGNAL	DB2	DB3	DB4	DB5	DB6	DB7	A	K

厦门精显电子有限公司 XIAMEN PRECISE DISPLAY CO., LTD.			
绘图: 刘永宝	绘图编号: PCM1602B-FL-YBS-03	单位: 厦门	
审核: CAO	客户编号: LCM1602B-FL-YBS-03	日期: 2008.03.16	
批准: ZHUANG	图纸版号: V1.0	页数: 1/1	

10.0 RELIABILITY TEST

Storage Condition	Content	Evaluations and Assessment*			
		Current Consumption	Oozing	Contrast	Other Appearances
Operation at high temperature and humidity	40°C,90% RH,240hrs	Twice initial value or less	none	More than 80% of initial value	No abnormality
High temperature storage	60°C, 240hrs	Twice initial value or less	none	More than 80% of initial value	No abnormality
Low temperature storage	-20°C, 240hrs	Twice initial value or less		More than 80% of initial value	No abnormality

*Evaluations and assessment to be made two hours after returning to room temperature (25°C±5°C).

*The LCDs subjected to the test must not have dew condensation.

➤ Display Data RAM (DDRAM)

DDRAM stores display data of maximum 80 x 8 bits (80 characters). DDRAM address is set in the address counter (AC) as a hexadecimal number.

Display position	1	2	3	4	5	6	7	8	9	10	11	12	13	14	15	16
DDRAM address	00	01	02	03	04	05	06	07	08	09	0A	0B	0C	0D	0E	0F
DDRAM address	40	41	42	43	44	45	46	47	48	49	4A	4B	4C	4D	4E	4F

11.0 DISPLAY INSTRUCTION TABLE

COMMAND	R S	R/ W	DB 7	DB 6	DB 5	DB 4	DB 3	DB 2	DB 1	DB 0	DESCRIPTION	Executing time fosc=250khz
Clear Display	0	0	0	0	0	0	0	0	0	1	Clears Display & Returns to Address 0.	1.64ms
Cursor at Home	0	0	0	0	0	0	0	0	1	x	Returns Cursor to Address 0. Also returns the display being shifted to the original position. DDRAM contents remain unchanged.	1.64ms
Entry Mode Set	0	0	0	0	0	0	0	1	I/D	S	I/D: Set Cursor Moving Direction I/D=1: Increment I/D=0: Decrement S: Specify Shift of Display S=1: The display is shifted S=0: The display is not shifted	40µs
Display ON/OFF Control	0	0	0	0	0	0	1	D	C	B	Display D=1: Display on D=0: Display off Cursor C=1: Cursor on C=0: Cursor off Brink B=1: Brink on B=0: Brink off	40µs
Cursor / Display Shift	0	0	0	0	0	1	S/C	R/L	x	x	Moves cursor or shifts the display w/o changing DD RAM contents S/C=0: Cursor Shift (RAM unchanged) S/C=1: Display Shift (RAM unchanged) R/L=1: Shift to the Right R/L=0: Shift to the Left	40µs
Function Set	0	0	0	0	1	DL	N	F	x	x	Sets data bus length (DL), # of display lines (N), and character fonts (F). DL=1: 8 bits F=0: 5x7 dots DL=0: 4 bits F=1: 5x10 dots N=0: 1 line display N=1: 2 lines display	40µs
Set CG RAM Address	0	0	0	1	Character Generator (CG) RAM Address						Sets CG RAM address. CG RAM data is sent and received after this instruction.	40µs
Set DD RAM Address	0	0	1	Display Data (DD) RAM Address / Cursor Address						Sets DD RAM address. DD Ram data is sent and received after this instruction.	40µs	
Busy Flag / Address Read	0	1	B F	Address counter used for both DD & CG RAM address						Reads Busy Flag (BF) and address counter contents.	40µs	
Write Data	1	0	Write Data								Writes data into DDRAM or CGRAM.	46µs
Read Data	1	1	Read Data								Reads data from DDRAM or CGRAM.	46µs

x: Don't Care

12.0 STANDARD CHARACTER PATTERNS

NO.7066-0A

b7-b4 b3-b0	0000	0001	0010	0011	0100	0101	0110	0111	1000	1001	1010	1011	1100	1101	1110	1111
0000	CG RAM (1)			0	1	2	3	4				5	6	7	8	9
0001	(2)		!	1	A	Q	a	A			.	7	#	G	3	g
0010	(3)		"	2	B	R	b	r			"	4	9	X	P	B
0011	(4)		#	3	C	S	c	s			!	5	T	E	e	*
0100	(5)		\$	4	D	T	d	t			\	6	I	t	P	a
0101	(6)		%	5	E	U	e	u			*	7	A	1	C	O
0110	(7)		&	6	F	V	f	v			7	0	2	3	P	Z
0111	(8)		^	7	G	U	g	u			7	7	X	7	g	A
1000	(1)		<	8	H	X	h	x			4	0	*	U	J	X
1001	(2)		>	9	I	Y	i	y			6	7	J	U	"	Y
1010	(3)		*	:	J	Z	j	z			=	3	n	v	J	7
1011	(4)		+	;	K	L	k	l			*	8	E	O	*	A
1100	(5)		,	<	L	Y	l	y			P	9	7	7	6	A
1101	(6)		-	=	M	I	m	i			u	X	^	7	6	÷
1110	(7)		.	>	N	^	n	^			B	E	6	^	n	
1111	(8)		/	?	O	L	o	l			u	U	7	"	o	

Note: The character generator RAM is the RAM with which the user can rewrite character patterns by program.