

REV.	DESCRIPTION	DRAWN	CHECKED	APPROVED
A	NEW RELEASE	LJH 06/22/05'		LJC 06/22/05'
B	HOUSING CHANGE Δ	JLZ 12/12/14'		LJC 12/12/14'
C	ADD P/N CODE \odot	JLZ 01/16/15'	HZW 01/16/15'	LJC 01/16/15'
D	DRAWING UPDATE	JLZ 08/18/16'		

NOTES:

- ELECTRICAL CHARACTERISTICS:
 - CONTACT RESISTANCE: 50m Ω Max. INITIAL.
 - DIELECTRIC WITHSTANDING VOLTAGE: 300V AC(rms) FOR 1 MINUTE.
 - INSULATION RESISTANCE: 1000M Ω Min.
- ENVIRONMENT CHARACTERISTICS:
 - OPERATING TEMPERATURE: -40°C~+105°C.
- PART NUMBER: DS1031-08
- PRODUCT NUMBER CODE:

DS1031-08 - X X X X X X X X - X

- PLATING LEVEL
3A: LEVEL 3A
- PACKING TYPE \odot
B:TUBE
R:TAPE ON REEL
T:TRAY
- PICK UP SUPPORT \odot
S: W/ PICK UP
X: W/O PICK UP
- DIM.A C TYPE
1: TYPE 1
.....
- HOUSING DIM.(DIM.B)
1: B=1.00mm
2: B=1.50mm
3: B=1.70mm
4: B=2.00mm
- MOUNTING TYPE
S: SMT TYPE
- HOUSING COLOR
B:BLACK
- CONTACT PLATING
8: FULL GOLD FLASH
- CONNECTOR TYPE
P:PLUG
- No.OF CONTACTS
2*1-2*40

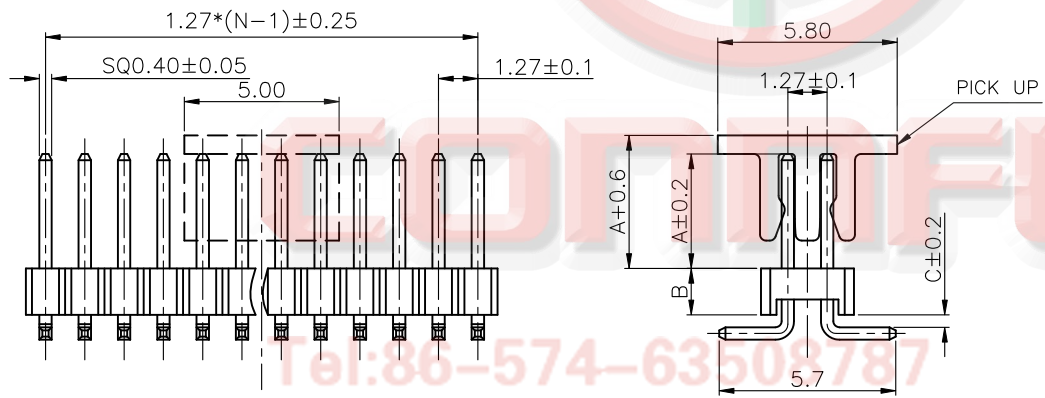
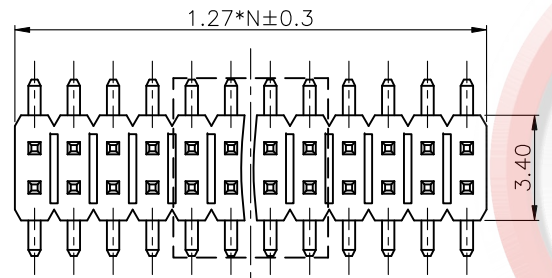

N:NUMBER OF CONTACTS/2

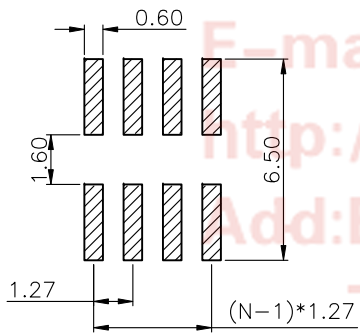

RECOMMEND PCB LAYOUT(TOLERANCE=±0.05)

TYPE	DIM A	DIM C
1	3.70	0.40
2	3.00	0.40
3	3.30	0.20
4	3.30	0.40
5	3.00	0.10

GENERAL TOLERANCE		ANGLE TOLERANCE	
X.	±0.60	X.	±5°
.X	±0.38	.X	±3°
.XX	±0.25	.XX	±2°

PROJECTION	TITLE
UNITS	PIN HEADER PITCH 1.27mm SMT TYPE
SHEET SIZE	SERIES DS1031-08 SERIES

DRAWING TYPE	CUSTOMER
SCALE	1:1 SHEET 1 OF 1
DRAWING NO.	C-DS1031-08-XXXXXXX-X-D

晨翔电子有限公司
CONNFLY CONNFLY ELECTRONIC CO. LTD