EM78P259N/260N

**8-Bit Microprocessor
with OTP ROM**

Product Specification

DOC. VERSION 1.1

ELAN MICROELECTRONICS CORP.

May 2006



Trademark Acknowledgments:

IBM is a registered trademark and PS/2 is a trademark of IBM.

Windows is a trademark of Microsoft Corporation.

ELAN and ELAN logo  are trademarks of ELAN Microelectronics Corporation.

Copyright © 2005~2006 by **ELAN Microelectronics Corporation**

All Rights Reserved

Printed in Taiwan

The contents of this specification are subject to change without further notice. ELAN Microelectronics assumes no responsibility concerning the accuracy, adequacy, or completeness of this specification. ELAN Microelectronics makes no commitment to update, or to keep current the information and material contained in this specification. Such information and material may change to conform to each confirmed order.

In no event shall ELAN Microelectronics be made responsible for any claims attributed to errors, omissions, or other inaccuracies in the information or material contained in this specification. ELAN Microelectronics shall not be liable for direct, indirect, special incidental, or consequential damages arising from the use of such information or material.

The software (if any) described in this specification is furnished under a license or nondisclosure agreement, and may be used or copied only in accordance with the terms of such agreement.

ELAN Microelectronics products are not intended for use in life support appliances, devices, or systems. Use of ELAN Microelectronics product in such applications is not supported and is prohibited.

NO PART OF THIS SPECIFICATION MAY BE REPRODUCED OR TRANSMITTED IN ANY FORM OR BY ANY MEANS WITHOUT THE EXPRESSED WRITTEN PERMISSION OF ELAN MICROELECTRONICS.



ELAN MICROELECTRONICS CORPORATION

Headquarters:

No. 12, Innovation Road 1
Hsinchu Science Park
Hsinchu, TAIWAN 30077
Tel: +886 3 563-9977
Fax: +886 3 563-9966
<http://www.emc.com.tw>

Hong Kong:

Elan (HK) Microelectronics Corporation, Ltd.
Rm. 1005B, 10/F Empire Centre
68 Mody Road, Tsimshatsui
Kowloon, HONG KONG
Tel: +852 2723-3376
Fax: +852 2723-7780
elanhk@emc.com.hk

USA:

Elan Information Technology Group (U.S.A.)
1821 Saratoga Ave., Suite 250
Saratoga, CA 95070
USA
Tel: +1 408 366-8225
Fax: +1 408 366-8220

Europe:

Elan Microelectronics Corp. (Europe)
Siewerdtstrasse 105
8050 Zurich, SWITZERLAND
Tel: +41 43 299-4060
Fax: +41 43 299-4079
<http://www.elan-europe.com>

Shenzhen:

Elan Microelectronics Shenzhen, Ltd.
SSMEC Bldg., 3F, Gaoxin S. Ave.
Shenzhen Hi-Tech Industrial Park
Shenzhen, Guandong, CHINA
Tel: +86 755 2601-0565
Fax: +86 755 2601-0500

Shanghai:

Elan Microelectronics Shanghai, Ltd.
23/Bldg. #115 Lane 572, Bibo Road
Zhangjiang Hi-Tech Park
Shanghai, CHINA
Tel: +86 21 5080-3866
Fax: +86 21 5080-4600

Contents

1	General Description	1
2	Features	1
3	Pin Assignment	3
	3.1 EM78P259NP/M	3
	3.2 EM78P260NP/M/KM	3
4	Block Diagram	4
5	Pin Description	5
	5.1 EM78P259NP/M	5
	5.2 EM78P260NP/M/KM	6
6	Function Description	7
	6.1 Operational Registers	7
	6.1.1 R0 (Indirect Address Register)	7
	6.1.2 R1 (Time Clock /Counter)	7
	6.1.3 R2 (Program Counter) and Stack	7
	6.1.3.1 Data Memory Configuration	9
	6.1.4 R3 (Status Register)	10
	6.1.5 R4 (RAM Select Register)	11
	6.1.6 R5 ~ R6 (Port 5 ~ Port 6)	11
	6.1.7 R7 (Port 7)	11
	6.1.8 R8 (AISR: ADC Input Select Register)	13
	6.1.9 R9 (ADCON: ADC Control Register)	13
	6.1.10 RA (ADOC: ADC Offset Calibration Register)	14
	6.1.11 RB (ADDATA: Converted Value of ADC)	15
	6.1.12 RC (ADDATA1H: Converted Value of ADC)	15
	6.1.13 RD (ADDATA1L: Converted Value of ADC)	15
	6.1.14 RE (Interrupt Status 2 & Wake-up Control Register)	16
	6.1.15 RF (Interrupt Status 2 Register)	17
	6.1.16 R10 ~ R3F	17
	6.2 Special Purpose Registers	18
	6.2.1 A (Accumulator)	18
	6.2.2 CONT (Control Register)	18
	6.2.3 IOC50 ~ IOC70 (I/O Port Control Register)	19
	6.2.4 IOC80 (Comparator and TCCA Control Register)	19
	6.2.5 IOC90 (TCCB and TCCC Control Register)	20
	6.2.6 IOCA0 (IR and TCCC Scale Control Register)	21
	6.2.7 IOCB0 (Pull-Down Control Register)	23
	6.2.8 IOCC0 (Open-Drain Control Register)	23
	6.2.9 IOCD0 (Pull-high Control Register)	24
	6.2.10 IOCE0 (WDT Control & Interrupt Mask Registers 2)	24

6.2.11	IOCF0 (Interrupt Mask Register).....	25
6.2.12	IOC51 (TCCA Counter).....	26
6.2.13	IOC61 (TCCB Counter).....	26
6.2.14	IOC71 (TCCBH/MSB Counter).....	27
6.2.15	IOC81 (TCCC Counter).....	27
6.2.16	IOC91 (Low-Time Register).....	28
6.2.17	IOCA1 (High Time Register).....	28
6.2.18	IOCB1 High/Low Time Scale Control Register).....	28
6.2.19	IOCC1 (TCC Prescaler Counter).....	29
6.3	TCC/WDT and Prescaler.....	30
6.4	I/O Ports.....	31
6.4.1	Usage of Port 5 Input Change Wake-up/Interrupt Function.....	34
6.5	Reset and Wake-up.....	34
6.5.1	Reset and Wake-up Operation.....	34
6.5.1.1	Wake-up and Interrupt Modes Operation Summary.....	37
6.5.1.2	Register Initial Values after Reset.....	39
6.5.1.3	Controller Reset Block Diagram.....	43
6.5.2	The T and P Status under Status (R3) Register.....	44
6.6	Interrupt.....	44
6.7	Analog-to-Digital Converter (ADC).....	47
6.7.1	ADC Control Register (AISR/R8, ADCON/R9, ADOC/RA).....	47
6.7.1.1	R8 (AISR: ADC Input Select Register).....	47
6.7.1.2	R9 (ADCON: AD Control Register).....	48
6.7.1.3	RA (ADOC: AD Offset Calibration Register).....	49
6.7.2	ADC Data Register (ADDATA/RB, ADDATA1H/RC, ADDATA1L/RD).....	50
6.7.3	ADC Sampling Time.....	50
6.7.4	AD Conversion Time.....	50
6.7.5	ADC Operation during Sleep Mode.....	50
6.7.6	Programming Process/Considerations.....	51
6.7.6.1	Programming Process.....	51
6.7.6.2	Sample Demo Programs.....	52
6.8	Infrared Remote Control Application/PWM Waveform Generation.....	54
6.8.1	Overview.....	54
6.8.2	Function Description.....	55
6.8.3	Programming the Related Registers.....	57
6.9	Timer/Counter.....	58
6.9.1	Overview.....	58
6.9.2	Function Description.....	58
6.9.3	Programming the Related Registers.....	60



6.10	Comparator	60
6.10.1	External Reference Signal	61
6.10.2	Comparator Outputs.....	61
6.10.3	Using a Comparator as an Operation Amplifier.....	62
6.10.4	Comparator Interrupt.....	62
6.10.5	Wake-up from Sleep Mode.....	62
6.11	Oscillator	63
6.11.1	Oscillator Modes.....	63
6.11.2	Crystal Oscillator/Ceramic Resonators (Crystal).....	64
6.11.3	External RC Oscillator Mode.....	65
6.11.4	Internal RC Oscillator Mode	66
6.12	Power-on Considerations	67
6.12.1	Programmable WDT Time-Out Period	67
6.12.2	External Power-on Reset Circuit	67
6.12.3	Residual Voltage Protection	68
6.13	Code Option	69
6.13.1	Code Option Register (Word 0).....	69
6.13.2	Code Option Register (Word 1).....	70
6.13.3	Customer ID Register (Word 2).....	71
6.14	Instruction Set	71
7	Absolute Maximum Ratings	73
8	DC Electrical Characteristics	74
8.1	AD Converter Characteristics.....	75
8.2	Comparator (OP) Characteristics	76
8.3	Device Characteristics.....	77
9	AC Electrical Characteristic	78
10	Timing Diagrams	79

APPENDIX

A	Package Types Summary	80
B	Packaging Configurations.....	80
B.1	18-Lead Plastic Dual in line (PDIP) – 300 mil	80
B.2	18-Lead Plastic Small Outline (SOP) – 300 mil.....	81
B.3	20-Lead Plastic Shrink Small Outline (SSOP) – 209 mil	82
B.4	20-Lead Plastic Dual-in-line (PDIP) – 300 mil	83
B.5	20-Lead Plastic Small Outline (SOPP) – 300 mil	84
C	Quality Assurance and Reliability	85
C.1	Address Trap Detect.....	85



Specification Revision History

Doc. Version	Revision Description	Date
1.0	Initial official version	2005/06/16
1.1	Added the IRC drift rate in the Features section.	2006/05/29



1 General Description

The EM78P259N and EM78P260N are 8-bit microprocessor designed and developed with low-power, high-speed CMOS technology. The devices in this series have on-chip 2K×13-bit Electrical One Time Programmable Read Only Memory (OTP-ROM). It provides Protection bits to prevent intrusion of user's code in the OTP memory as well as from unwanted external accesses. Three Code Option bits are also available to meet user's application requirements.

With its enhanced OTP-ROM features, the EM78P259N and EM78P260N provide a convenient way of developing and verifying user's programs. Moreover, this OTP devices offer the advantages of easy and effective program updates, using development and programming tools. User can avail of the ELAN Writer to easily program his development code.

2 Features

- Operating voltage range: 2.3V~5.5V base on 0°C ~ 70°C (commercial)
2.5V~5.5V base on -40°C ~ 85°C (industrial)
- Operating frequency range (base on 2 clocks):
 - Crystal mode: DC ~ 20MHz/2clks, 5V; DC ~ 8MHz/2clks, 3V
 - ERC mode: DC ~ 4MHz/2clks, 5V; DC ~ 4MHz/2clks, 3V
 - IRC mode: 4MHz at 2.3~5.5VProcess deviation: Typ. ±3%, max. ±5%
Temperature deviation: ±10% (-40°C~85°C)
- Low power consumption:
 - Less than 1.9 mA at 5V/4MHz
 - 15 µA Typ. at 3V/32kHz
 - 1 µA Typ. during sleep mode
- Built-in RC oscillator 4MHz, 8MHz, 1MHz, 455kHz (auto calibration)
- Programmable WDT time (4.5ms: 18ms)
- Independent Programmable WDT prescaler
- One configuration register to match user's requirements, and user's ID code for customer use is provided
- 80×8 on-chip registers (SRAM, general purpose register)
- 2K×13 on-chip ROM
- Bidirectional I/O ports
- 8-level stacks for subroutine nesting
- 8-bit real time clock/counter (TCC) with selective signal sources, trigger edges, and overflow interrupt



- 8-bit real time clock/counter (TCCA, TCCC) and 16-bit real time clock/counter (TCCB) with selective signal sources, trigger edges, and overflow interrupt
- One pair of comparators (can act as an OP)
- 4-bit multi-channel Analog-to-Digital Converter with 12-bit resolution
- Easily-implemented IR (Infrared remote control) application circuit
- Power down (Sleep) mode
- Six interrupt sources:
 - TCC, TCCA, TCCB, and TCCC overflow interrupt
 - Input-port status change interrupt (wake-up from sleep mode)
 - External interrupt
 - Comparators status change interrupt
 - IR/PWM interrupt
 - ADC completion interrupt
- Programmable free running watchdog timer
- 8 programmable pull-high I/O pins
- 8 programmable open-drain I/O pins
- 8 programmable pull-down I/O pins.
- Two or Four clocks per instruction cycle
- Package type:
 - 18-pin DIP 300mil : EM78P259NP
 - 18-pin SOP 300mil : EM78P259NM
 - 20-pin DIP 300mil : EM78P260NP
 - 20-pin SOP 300mil : EM78P260NM
 - 20-pin SSOP 209mil : EM78P260NKM
- Power-on voltage detector available (2.0V \pm 0.1V)

3 Pin Assignment

3.1 EM78P259NP/M

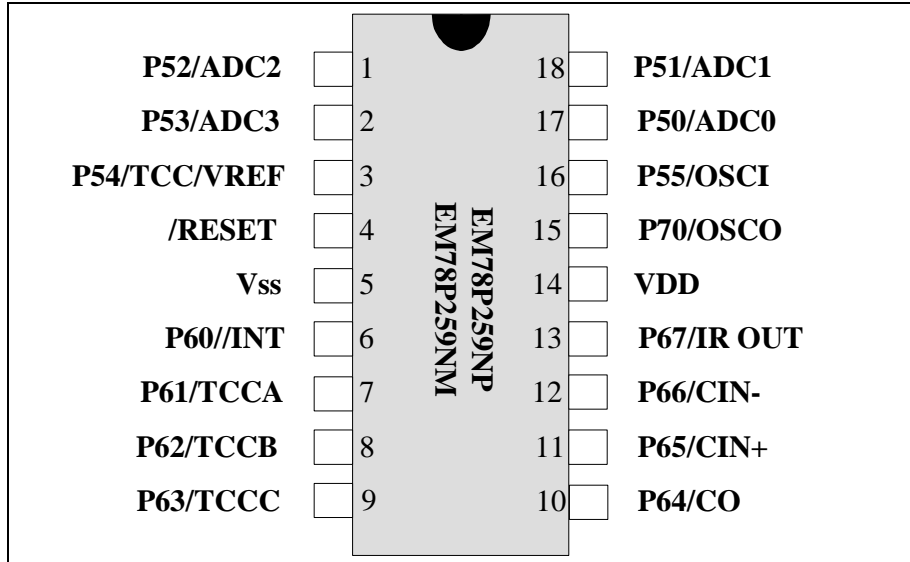

Fig 3-1 EM78P259NP/M Pin Assignment

3.2 EM78P260NP/M/KM

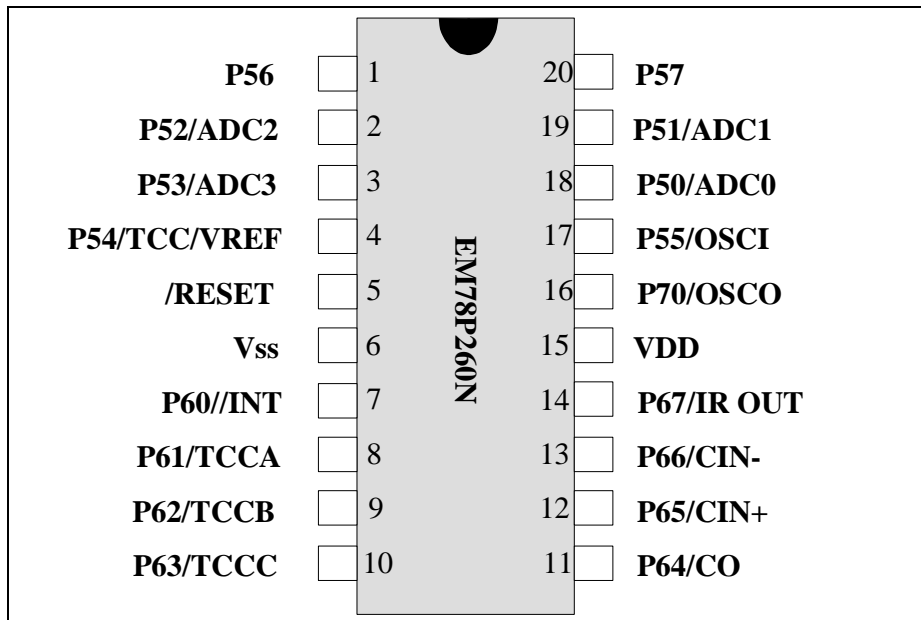

Fig 3-2 EM78P260NP/M/KM Pin Assignment



4 Block Diagram

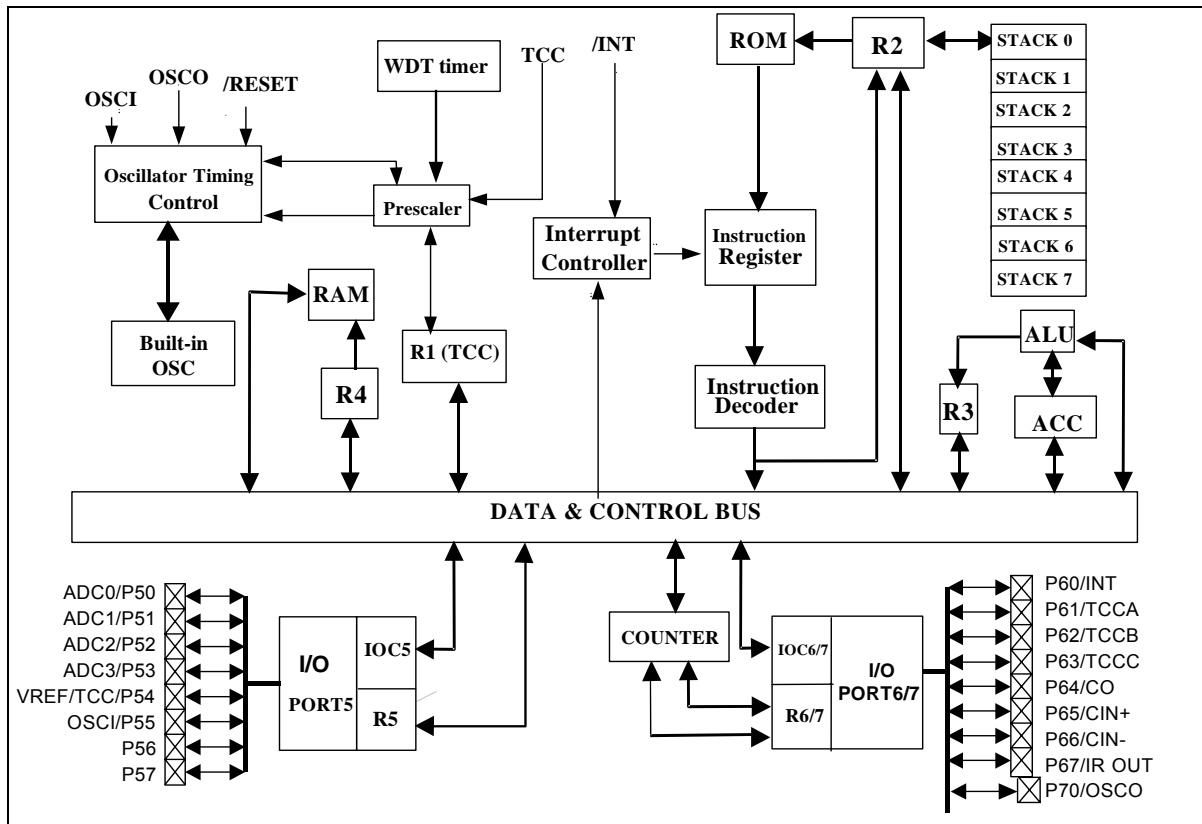

Fig 4-1 EM78P259N/260N Functional Block Diagram

5 Pin Description

5.1 EM78P259NP/M

Symbol	Pin No.	Type	Function
VDD	14	–	Power supply
OSCI	16	I	Crystal type: Crystal input terminal or external clock input pin RC type: RC oscillator input pin
OSCO	15	I/O	Crystal type: Output terminal for crystal oscillator or external clock input pin RC type: Clock output with a duration one instruction cycle External clock signal input
P70	15	I/O	General-purpose I/O pin Default value at power-on reset
P60 ~ P67	6 ~ 13	I/O	General-purpose I/O pin Open drain Default value at power-on reset
P50 ~ P55	1 ~ 3 16 ~ 18	I/O	General-purpose I/O pin Pull-high/pull-down Wake up from sleep mode when the status of the pin changes Default value at power-on reset
CIN–, CIN+ CO	12, 11 10	I O	“–” → input pin of Vin– of a comparator “+” → input pin of Vin+ of a comparator Pin CO is the output of the comparator Defined by IOC80 <4:3>
IR OUT	13	O	IR mode output pin. Capable of driving a sinking current = 20mA when the output voltage drops to 0.7V _{dd} and rise to 0.3V _{dd} at V _{dd} =5V
VREF	3	I	External reference voltage for ADC Defined by ADCON (R9)<7>
/INT	6	I	External interrupt pin triggered by a falling or rising edge Defined by CONT <7>
TCC, TCCA, TCCB, TCCC	3, 7, 8, 9	I	External Counter input TCC defined by CONT<5> TCCA defined by IOC80 <1> TCCB defined by IOC90 <5> TCCC defined by IOC90 <1>
ADC0 ~ ADC3	1, 2, 17, 18	I	Analog to Digital Converter Defined by ADCON (R9)<1:0>
/RESET	4	I	If it remains at logic low, the device will be reset Wake-up from sleep mode when pin status changes Voltage on /RESET/V _{pp} must not exceed V _{dd} during normal mode
VSS	5	–	Ground

5.2 EM78P260NP/M/KM

Symbol	Pin No.	Type	Function
VDD	15	–	Power supply
OSCI	17	I	Crystal type: Crystal input terminal or external clock input pin RC type: RC oscillator input pin
OSCO	16	I/O	Crystal type: Output terminal for crystal oscillator or external clock input pin RC type: Clock output with a duration one instruction cycle External clock signal input
P70	16	I/O	General-purpose I/O pin Default value at power-on reset
P60 ~ P67	7 ~ 14	I/O	General-purpose I/O pin Open drain Default value at power-on reset
P50 ~ P57	1 ~ 4 17 ~ 20	I/O	General-purpose I/O pin Pull-high/pull-down Wake up from sleep mode when the status of the pin changes Default value at power-on reset
CIN–, CIN+ CO	13, 12 11	I O	“–” → input pin of Vin– of a comparator “+” → input pin of Vin+ of a comparator Pin CO is the output of the comparator Defined by IOC80 <4:3>
IR OUT	14	O	IR mode output pin. Capable of driving a sinking current = 20mA when the output voltage drops to 0.7Vdd and rise to 0.3Vdd at Vdd=5V
VREF	4	I	External reference voltage for ADC Defined by ADCON (R9)<7>
/INT	7	I	External interrupt pin triggered by a falling or rising edge Defined by CONT <7>
TCC, TCCA, TCCB, TCCC	4, 8, 9, 10	I	External Counter input TCC defined by CONT<5> TCCA defined by IOC80 <1> TCCB defined by IOC90 <5> TCCC defined by IOC90 <1>
ADC0 ~ ADC3	2, 3, 18, 19	I	Analog to Digital Converter Defined by ADCON (R9)<1:0>
/RESET	5	I	If it remains at logic low, the device will be reset Wake-up from sleep mode when pin status changes Voltage on /RESET/Vpp must not exceed Vdd during normal mode
VSS	6	–	Ground

6 Function Description

6.1 Operational Registers

6.1.1 R0 (Indirect Address Register)

R0 is not a physically implemented register. It is used as an indirect addressing pointer. Any instruction using R0 as a pointer actually accesses data pointed by the RAM Select Register (R4).

6.1.2 R1 (Time Clock/Counter)

- Incremented by an external signal edge which is defined by the TE bit (CONT-4) through the TCC pin, or by the instruction cycle clock.
- Writable and readable as any other registers
- The TCC prescaler counter (IOCC1) is assigned to TCC
- The contents of the IOCC1 register is cleared whenever:
 - a value is written to TCC register
 - a value is written to TCC prescaler bits (Bits 3, 2, 1, 0 of the CONT register)
 - a power-on reset, /RESET, or WDT time out reset occurs

6.1.3 R2 (Program Counter) and Stack

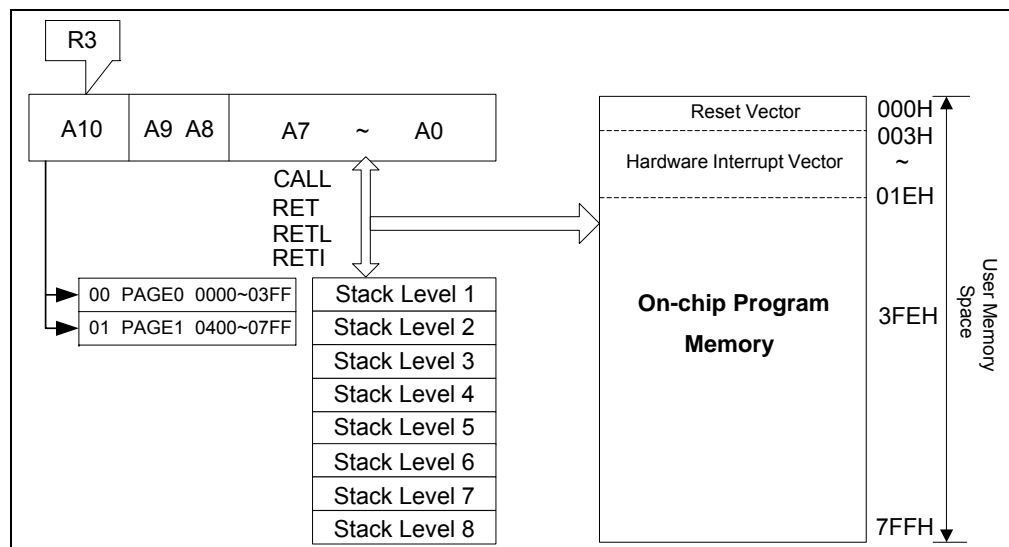

Fig 5-2 Program Counter Organization

- R2 and hardware stacks are 12-bit wide. The structure is depicted in the table under Section 6.1.3.1, *Data Memory Configuration* (next page).
- The configuration structure generates $2K \times 13$ bits on-chip ROM addresses to the relative programming instruction codes. One program page is 1024 words long.
- The contents of R2 are all set to "0"s when a Reset condition occurs.



- "JMP" instruction allows direct loading of the lower 10 program counter bits. Thus, "JMP" allows the PC to jump to any location within a page.
- "CALL" instruction loads the lower 10 bits of the PC, and then PC+1 is pushed onto the stack. Thus, the subroutine entry address can be located anywhere within a page.
- "RET" ("RETL k", "RETI") instruction loads the program counter with the contents of the top of stack.
- "ADD R2, A" allows a relative address to be added to the current PC, and the ninth and above bits of the PC will increase progressively.
- "MOV R2, A" allows loading of an address from the "A" register to the lower 8 bits of the PC, and the ninth and tenth bits (A8 ~ A9) of the PC will remain unchanged.
- Any instruction (except "ADD R2,A") that is written to R2 (e.g., "MOV R2, A", "BC R2, 6",.....) will cause the ninth bit and the tenth bit (A8 ~ A9) of the PC to remain unchanged.
- In the case of EM78P259N/260N, the most significant bit (A10) will be loaded with the content of PS0 in the status register (R3) upon execution of a "JMP", "CALL", or any other instructions set which write to R2.
- All instructions are single instruction cycle (fclk/2 or fclk/4) except for the instructions that are written to R2. Note that these instructions need one or two instructions cycle as determined by Code Option Register CYES bit.



6.1.3.1 Data Memory Configuration

Address	R PAGE registers		IOCX0 PAGE registers	IOCX1 PAGE registers
00	R0 (Indirect Addressing Register)		Reserve	Reserve
01	R1 (Time Clock Counter)		CONT (Control Register)	Reserve
02	R2 (Program Counter)		Reserve	Reserve
03	R3 (Status Register)		Reserve	Reserve
04	R4 (RAM Select Register)		Reserve	Reserve
05	R5 (Port5)		IOC50 (I/O Port Control Register)	IOC51 (TCCA Counter)
06	R6 (Port6)		IOC60 (I/O Port Control Register)	IOC61 (TCCB LSB Counter)
07	R7 (Port7)		IOC70 (I/O Port Control Register)	IOC71 (TCCB HSB Counter)
08	R8 (ADC Input Select Register)		IOC80 (Comparator and TCCA Control Register)	IOC81 (TCCC Counter)
09	R9 (ADC Control Register)		IOC90 (TCCB and TCCC Control Register)	IOC91 (Low-Time Register)
0A	RA (ADC Offset Calibration Register)		IOCA0 (IR and TCCC Scale Control Register)	IOCA1 (High-Time Register)
0B	RB (The converted value AD11~AD4 of ADC)		IOCB0 (Pull-down Control Register)	IOCB1 (High-Time and Low-Time Scale control Register)
0C	RC (The converted value AD11~AD8 of ADC)		IOCC0 (Open-drain Control Register)	IOCC1 (TCC Prescaler Control)
0D	RD (The converted value AD7~AD0 of ADC)		IOCD0 (Pull-high Control Register)	Reserve
0E	RE (Interrupt Status 2 and Wake-Up Control Register)		IOCE0 (WDT Control Register and Interrupt Mask Register 2)	Reserve
0F	RF (Interrupt Status Register 1)		IOCF0 (Interrupt Mask Register 1)	Reserve
10 : 1F	General Registers			
20 : 3F	Bank 0	Bank 1		



6.1.4 R3 (Status Register)

Bit 7	Bit 6	Bit 5	Bit 4	Bit 3	Bit 2	Bit 1	Bit 0
RST	IOCS	PS0	T	P	Z	DC	C

Bit 7 (RST): Bit of reset type

Set to "1" if wake-up from sleep on pin change, comparator status change, or AD conversion completed. Set to "0" if wake-up from other reset types

Bit 6 (IOCS): Select the Segment of IO control register

0 = Segment 0 (IOC50 ~ IOCF0) selected
1 = Segment 1 (IOC51 ~ IOCC1) selected

Bit 5 (PS0): Page select bit. PS0 is used to select a program memory page. When executing a "JMP," "CALL," or other instructions which cause the program counter to change (e.g., MOV R2, A), PS0 is loaded into the 11th bit of the program counter where it selects one of the available program memory pages. Note that RET (RETL, RETI) instruction does not change the PS0 bit. That is, the return will always be back to the page from where the subroutine was called, regardless of the current PS0 bit setting.

PS0	Program Memory Page [Address]
0	Page 0 [000-3FF]
1	Page 1 [400-7FF]

Bit 4 (T): Time-out bit. Set to "1" by the "SLEP" and "WDTC" commands or during power on; and reset to "0" by WDT time-out (see Section 6.5.2, *The T and P Status under STATUS Register* for more details).

Bit 3 (P): Power-down bit. Set to "1" during power-on or by a "WDTC" command and reset to "0" by a "SLEP" command (see Section 6.5.2, *The T and P Status under STATUS Register* for more details).

Bit 2 (Z): Zero flag. Set to "1" if the result of an arithmetic or logic operation is zero.

Bit 1 (DC): Auxiliary carry flag

Bit 0 (C): Carry flag

6.1.5 R4 (RAM Select Register)

- Bit 7:** Set to "0" all the time
- Bit 6:** Used to select Bank 0 or Bank 1 of register
- Bits 5~0:** Used to select a register (address: 00~0F, 10~3F) in the indirect addressing mode

See the table under Section 6.1.3.1, *Data Memory Configuration* for data memory configuration.

6.1.6 R5 ~ R6 (Port 5 ~ Port 6)

- R5 & R6** are I/O registers
- The upper 2 bits of R5 are fixed to "0" (if EM78P259N is selected). Only the lower 6 bits of R5 are available (this applies to EM78P259N only as EM78P260N can use all the bits)

6.1.7 R7 (Port 7)

Bit	Bit 7	Bit 6	Bit 5	Bit 4	Bit 3	Bit 2	Bit 1	Bit 0
EM78P259N/260N	'0'	'0'	'0'	'0'	'0'	'0'	'0'	I/O
ICE259N	C3	C2	C1	C0	RCM1	RCM0	'0'	I/O

NOTE

- R7 is an I/O register
- For EM78P259N/260N, only the lower 1 bit of R7 is available.

Bit 7 ~ Bit 2:

[With EM78P259N/260N]: Unimplemented, read as '0'.

[With Simulator (C3~C0, RCM1, & RCM0)]: are IRC calibration bits in IRC oscillator mode. Under IRC oscillator mode of ICE259N simulator, these are the IRC mode selection bits and IRC calibration bits.



Bit 7 ~ Bit 4 (C3 ~ C0): Calibration bits for internal RC mode

C3	C2	C1	C0	Frequency (MHz)
0	0	0	0	(1-36%) x F
0	0	0	1	(1-31.5%) x F
0	0	1	0	(1-27%) x F
0	0	1	1	(1-22.5%) x F
0	1	0	0	(1-18%) x F
0	1	0	1	(1-13.5%) x F
0	1	1	0	(1-9%) x F
0	1	1	1	(1-4.5%) x F
1	1	1	1	F (default)
1	1	1	0	(1+4.5%) x F
1	1	0	1	(1+9%) x F
1	1	0	0	(1+13.5%) x F
1	0	1	1	(1+18%) x F
1	0	1	0	(1+22.5%) x F
1	0	0	1	(1+27%) x F
1	0	0	0	(1+31.5%) x F

1. Frequency values shown are theoretical and taken at an instance of a high frequency mode. Hence, frequency values are shown for reference only. Definite values depend on the actual process.
2. Similar way of calculation is also applicable to low frequency mode.

Bit 3 & Bit 2 (RCM1, RCM0): IRC mode selection bits

RCM 1	RCM 0	Frequency (MHz)
1	1	4 (default)
1	0	8
0	1	1
0	0	455kHz

6.1.8 R8 (AISR: ADC Input Select Register)

The AISR register defines the pins of Port 5 as analog inputs or as digital I/O, individually.

Bit 7	Bit 6	Bit 5	Bit 4	Bit 3	Bit 2	Bit 1	Bit 0
–	–	–	–	ADE3	ADE2	ADE1	ADE0

Bit 7 ~ Bit 4: Not used

Bit 3 (ADE3): AD converter enable bit of P53 pin
0 = Disable ADC3, P53 acts as I/O pin
1 = Enable ADC3, acts as analog input pin

Bit 2 (ADE2): AD converter enable bit of P52 pin
0 = Disable ADC2, P52 acts as I/O pin
1 = Enable ADC2, acts as analog input pin

Bit 1 (ADE1): AD converter enable bit of P51 pin
0 = Disable ADC1, P51 acts as I/O pin
1 = Enable ADC1, acts as analog input pin

Bit 0 (ADE0): AD converter enable bit of P50 pin.
0 = Disable ADC0, P50 acts as I/O pin
1 = Enable ADC0, acts as analog input pin

6.1.9 R9 (ADCON: ADC Control Register)

Bit 7	Bit 6	Bit 5	Bit 4	Bit 3	Bit 2	Bit 1	Bit 0
VREFS	CKR1	CKR0	ADRUN	ADPD	–	ADIS1	ADIS0

Bit 7 (VREFS): The input source of the Vref of the ADC

0 = The Vref of the ADC is connected to Vdd (default value), and the P54/VREF pin carries out the function of P54

1 = The Vref of the ADC is connected to P54/VREF

NOTE

- The P54/TCC/VREF pin cannot be applied to TCC and VREF at the same time. If P53/TCC/VREF acts as VREF analog input pin, then CONT Bit 5 “TS” must be “0.”
- The P54/TCC/VREF pin priority is as follows:

P53/TCC/VREF Pin Priority		
High	Medium	Low
VREF	TCC	P54



Bit 6 & Bit 5 (CKR1 & CKR0): The prescaler of oscillator clock rate of ADC

- 00 = 1: 16 (default value)
- 01 = 1: 4
- 10 = 1: 64
- 11 = 1: WDT ring oscillator frequency

CKR1:CKR0	Operation Mode	Max. Operation Frequency
00	Fsco/16	4 MHz
01	Fsco/4	1 MHz
10	Fsco/64	16MHz
11	Internal RC	–

Bit 4 (ADRUN): ADC starts to RUN.

- 1 = an AD conversion is started. This bit can be set by software
- 0 = Reset upon completion of the conversion. This bit **cannot** be reset by software

Bit 3 (ADPD): ADC Power-down mode

- 1 = ADC is operating
- 0 = Switch off the resistor reference to save power even while the CPU is operating

Bit 2: Not used

Bit 1 ~ Bit 0 (ADIS1 ~ADIS0): Analog Input Select

- 00 = ADIN0/P50
- 01 = ADIN1/P51
- 10 = ADIN2/P52
- 11 = ADIN3/P53

These bits can only be changed when the ADIF bit (see Section 6.1.14, *RE (Interrupt Status 2 & Wake-Up Control Register)*) and the ADRUN bit are both LOW.

6.1.10 RA (ADOC: ADC Offset Calibration Register)

Bit 7	Bit 6	Bit 5	Bit 4	Bit 3	Bit 2	Bit 1	Bit 0
CALI	SIGN	VOF[2]	VOF[1]	VOF[0]	"0"	"0"	"0"

Bit 7 (CALI): Calibration enable bit for ADC offset

- 0 = Calibration disable
- 1 = Calibration enable

Bit 6 (SIGN): Polarity bit of offset voltage

- 0 = Negative voltage
- 1 = Positive voltage



Bit 5 ~ Bit 3 (VOF[2] ~ VOF[0]): Offset voltage bits

VOF[2]	VOF[1]	VOF[0]	EM78P259N/260N	ICE259N
0	0	0	0LSB	0LSB
0	0	1	2LSB	1LSB
0	1	0	4LSB	2LSB
0	1	1	6LSB	3LSB
1	0	0	8LSB	4LSB
1	0	1	10LSB	5LSB
1	1	0	12LSB	6LSB
1	1	1	14LSB	7LSB

Bit 2 ~ Bit 0: Unimplemented, read as '0'

6.1.11 RB (ADDATA: Converted Value of ADC)

Bit 7	Bit 6	Bit 5	Bit 4	Bit 3	Bit 2	Bit 1	Bit 0
AD11	AD10	AD9	AD8	AD7	AD6	AD5	AD4

When the AD conversion is completed, the result is loaded into the ADDATA. The ADRUN bit is cleared, and the ADIF (see Section 6.1.14, *RE (Interrupt Status 2 & Wake-up Control Register)*) is set.

RB is read only.

6.1.12 RC (ADDATA1H: Converted Value of ADC)

Bit 7	Bit 6	Bit 5	Bit 4	Bit 3	Bit 2	Bit 1	Bit 0
"0"	"0"	"0"	"0"	AD11	AD10	AD9	AD8

When the AD conversion is completed, the result is loaded into the ADDATA1H. The ADRUN bit is cleared, and the ADIF (see Section 6.1.14, *RE (Interrupt Status 2 & Wake-up Control Register)*) is set.

RC is read only

6.1.13 RD (ADDATA1L: Converted Value of ADC)

Bit 7	Bit 6	Bit 5	Bit 4	Bit 3	Bit 2	Bit 1	Bit 0
AD7	AD6	AD5	AD4	AD3	AD2	AD1	AD0

When the AD conversion is completed, the result is loaded into the ADDATA1L. The ADRUN bit is cleared, and the ADIF (see Section 6.1.14, *RE (Interrupt Status 2 & Wake-Up Control Register)*) is set.

RD is read only



6.1.14 RE (Interrupt Status 2 & Wake-up Control Register)

Bit 7	Bit 6	Bit 5	Bit 4	Bit 3	Bit 2	Bit 1	Bit 0
-	-	ADIF	CMPIF	ADWE	CMPWE	ICWE	-

NOTE

- RE <5, 4> can be cleared by instruction but cannot be set.
- IOCE0 is the interrupt mask register.
- Reading RE will result to "logic AND" of RE and IOCE0.

Bit 7 & Bit 6: Not used

Bit 5 (ADIF): Interrupt flag for analog to digital conversion. Set when AD conversion is completed. Reset by software

0 = no interrupt occurs

1 = with interrupt request

Bit 4 (CMPIF): Comparator interrupt flag. Set when a change occurs in the output of the Comparator. Reset by software.

0 = no interrupt occurs

1 = with interrupt request

Bit 3 (ADWE): ADC wake-up enable bit

0 = Disable ADC wake-up

1 = Enable ADC wake-up

When AD Conversion enters into sleep mode, this bit must be set to "Enable".

Bit 2 (CMPWE): Comparator wake-up enable bit

0 = Disable Comparator wake-up

1 = Enable Comparator wake-up

When Comparator enters into sleep mode, this bit must be set to "Enable."

Bit 1 (ICWE): Port 5 input change to wake-up status enable bit

0 = Disable Port 5 input change to wake-up status

1 = Enable Port 5 input change to wake-up status

When Port 5 change enters sleep mode, this bit must be set to "Enable".

Bit 0: Not implemented, read as '0'

6.1.15 RF (Interrupt Status 2 Register)

Bit 7	Bit 6	Bit 5	Bit 4	Bit 3	Bit 2	Bit 1	Bit 0
LPWTIF	HPWTIF	TCCCIF	TCCBIF	TCCAIF	EXIF	ICIF	TCIF

NOTE

- "1" means interrupt request; "0" means no interrupt occurs.
- RF can be cleared by instruction but cannot be set.
- IOCF0 is the relative interrupt mask register.
- Reading RF will result to "logic AND" of RF and IOCF0.

- Bit 7 (LPWTIF):** Internal low-pulse width timer underflow interrupt flag for IR/PWM function. Reset by software.
- Bit 6 (HPWTIF):** Internal high-pulse width timer underflow interrupt flag for IR/PWM function. Reset by software.
- Bit 5 (TCCCIF):** TCCC overflow interrupt flag. Set when TCCC overflows. Reset by software.
- Bit 4 (TCCBIF):** TCCB overflow interrupt flag. Set when TCCC overflows. Reset by software.
- Bit 3 (TCCAIF):** TCCA overflow interrupt flag. Set when TCCC overflows. Reset by software.
- Bit 2 (EXIF):** External interrupt flag. Set by falling edge on /INT pin. Reset by software.
- Bit 1 (ICIF):** Port 5 input status change interrupt flag. Set when Port 5 input changes. Reset by software.
- Bit 0 (TCIF):** TCC overflow interrupt flag. Set when TCC overflows. Reset by software.

6.1.16 R10 ~ R3F

All of these are 8-bit general-purpose registers.



6.2 Special Function Registers

6.2.1 A (Accumulator)

Internal data transfer operation, or instruction operand holding usually involves the temporary storage function of the Accumulator, which is not an addressable register.

6.2.2 CONT (Control Register)

Bit 7	Bit 6	Bit 5	Bit 4	Bit 3	Bit 2	Bit 1	Bit 0
INTE	INT	TS	TE	PSTE	PST2	PST1	PST0

NOTE

- The CONT register is both readable and writable.
- Bit 6 is read only.

Bit 7 (INTE): INT signal edge

- 0 = interrupt occurs at the rising edge of the INT pin
- 1 = interrupt occurs at the falling edge of the INT pin

Bit 6 (INT): Interrupt enable flag

- 0 = masked by DISI or hardware interrupt
- 1 = enabled by the ENI/RETI instructions

This bit is readable only.

Bit 5 (TS): TCC signal source

- 0 = internal instruction cycle clock. P54 is a bidirectional I/O pin.
- 1 = transition on the TCC pin

Bit 4 (TE): TCC signal edge

- 0 = increment if the transition from low to high takes place on the TCC pin
- 1 = increment if the transition from high to low takes place on the TCC pin

Bit 3 (PSTE): Prescaler enable bit for TCC

- 0 = prescaler disable bit. TCC rate is 1:1
- 1 = prescaler enable bit. TCC rate is set as Bit 2 ~ Bit 0.

Bit 2 ~ Bit 0 (PST2 ~ PST0): TCC prescaler bits

PST2	PST1	PST0	TCC Rate
0	0	0	1:2
0	0	1	1:4
0	1	0	1:8
0	1	1	1:16
1	0	0	1:32
1	0	1	1:64
1	1	0	1:128
1	1	1	1:256

NOTE

Tcc timeout period [1/Fosc x prescaler x 256 (Tcc cnt) x 1 (CLK=2)]
Tcc timeout period [1/Fosc x prescaler x 256 (Tcc cnt) x 2 (CLK=4)]

6.2.3 IOC50 ~ IOC70 (I/O Port Control Register)

- "1" sets the relative I/O pin into high impedance, while "0" defines the relative I/O pin as output.
- Only the lower 6 bits of **IOC50** can be defined (this applies to EM78P259N only as EM78P260N can use all the bits).
- Only the lower 1 bit of **IOC70** can be defined, the other bits are not available.
- **IOC50**, **IOC60**, and **IOC70** registers are all readable and writable

6.2.4 IOC80 (Comparator and TCCA Control Register)

Bit 7	Bit 6	Bit 5	Bit 4	Bit 3	Bit 2	Bit 1	Bit 0
–	–	CMPOUT	COS1	COS0	TCCAEN	TCCATS	TCCATE

NOTE

- Bits 4 ~ 0 of the **IOC80** register are both readable and writable.
- Bit 5 of the **IOC80** register is readable only.

Bit 7 & Bit 6: Not used

Bit 5 (CMPOUT): The result of the comparator output
This bit is readable only.



Bit 4 & Bit 3 (COS1 & COS0): Comparator/OP Select bits

COS1	COS0	Function Description
0	0	Comparator and OP not used. P64, P65, and P66 act as normal I/O pin
0	1	Acts as Comparator and P64 acts as normal I/O pin
1	0	Acts as Comparator and P64 acts as Comparator output pin (CO)
1	1	Acts as OP and P64 acts as OP output pin (CO)

Bit 2 (TCCAEN): TCCA enable bit

0 = disable TCCA

1 = enable TCCA as a counter

Bit 1 (TCCATS): TCCA signal source

0 = internal instruction cycle clock. P61 is a bi-directional I/O pin

1 = transit through the TCCA pin

Bit 0 (TCCATE): TCCA signal edge

0 = increment if transition from low to high takes place on the TCCA pin

1 = increment if transition from high to low takes place on the TCCA pin

6.2.5 IOC90 (TCCB and TCCC Control Register)

Bit 7	Bit 6	Bit 5	Bit 4	Bit 3	Bit 2	Bit 1	Bit 0
TCCBHE	TCCBEN	TCCBTS	TCCBTE	–	TCCEN	TCCCTS	TCCCTE

Bit 7 (TCCBHE): Control bit is used to enable the most significant byte of counter

1 = Enable the most significant byte of TCCBH
TCCB is a 16-bit counter

0 = Disable the most significant byte of TCCBH (default value)
TCCB is an 8-bit counter

Bit 6 (TCCBEN): TCCB enable bit

0 = disable TCCB

1 = enable TCCB as a counter

Bit 5 (TCCBTS): TCCB signal source

0 = internal instruction cycle clock. P62 is a bi-directional I/O pin.

1 = transit through the TCCB pin



Bit 4 (TCCBTE): TCCB signal edge

0 = increment if the transition from low to high takes place on the TCCB pin

1 = increment if the transition from high to low takes place on the TCCB pin

Bit 3: Not used

Bit 2 (TCCEN): TCCC enable bit

0 = disable TCCC

1 = enable TCCC as a counter

Bit 1 (TCCCTS) TCCC signal source

0 = internal instruction cycle clock. P63 is a bidirectional I/O pin.

1 = transit through the TCCC pin

Bit 0 (TCCCTE): TCCC signal edge

0 = increment if the transition from low to high takes place on the TCCC pin

1 = increment if the transition from high to low takes place on the TCCC pin

6.2.6 IOCA0 (IR and TCCC Scale Control Register)

Bit 7	Bit 6	Bit 5	Bit 4	Bit 3	Bit 2	Bit 1	Bit 0
TCCCSE	TCCCS2	TCCCS1	TCCCS0	IRE	HF	LGP	IRROUTE

Bit 7 (TCCCSE): Scale enable bit for TCCC

An 8-bit counter is provided as scale for TCCC and IR-Mode. When in IR-Mode, TCCC counter scale uses the low-time segments of the pulse generated by F_{carrier} frequency modulation (see Fig. 6-11 in Section 6.8.2, *Function Description*).

0 = scale disable bit, TCCC rate is 1:1

1 = scale enable bit, TCCC rate is set as Bit 6 ~ Bit 4



Bit 6 ~ Bit 4 (TCCCS2 ~ TCCCS0): TCCC scale bits

The TCCCS2 ~ TCCCS0 bits of the IOCA0 register are used to determine the scale ratio of TCCC as shown below:

TCCCS2	TCCCS1	TCCCS0	TCCC Rate
0	0	0	1:2
0	0	1	1:4
0	1	0	1:8
0	1	1	1:16
1	0	0	1:32
1	0	1	1:64
1	1	0	1:128
1	1	1	1:256

Bit 3 (IRE):

Infrared Remote Enable bit

0 = Disable IRE, i.e., disable H/W Modulator Function. IROUT pin fixed to high level and the TCCC is UP Counter.

1 = Enable IRE, i.e., enable H/W Modulator Function. Pin 67 defined as IROUT. If HP=1, the TCCC counter scale uses the low-time segments of the pulse generated by Fcarrier frequency modulation (see Fig. 6-11 in Section 6.8.2, *Function Description*). When HP=0, the TCCC is UP Counter.

Bit 2 (HF):

High Frequency bit

0 = PWM application. IROUT waveform is achieved according to high-pulse width timer and low-pulse width timer which determine the high time width and low time width respectively

1 = IR application mode. The low-time segments of the pulse generated by Fcarrier frequency modulation (see Fig. 6-11 in Section 6.8.2, *Function Description*)

Bit 1 (LGP):

Long Pulse

0 = high-time and low-time register is valid

1 = high-time register is ignored. A single pulse is generated.

Bit 0 (IROUTE):

Control bit to define the P67 (IROUT) pin function

0 = P67 defined as bidirectional I/O pin

1 = P67 defined as IROUT. Under this condition, the I/O control bit of P67 (Bit 7 of IOC60) must be set to "0"



6.2.7 IOCB0 (Pull-down Control Register)

Bit 7	Bit 6	Bit 5	Bit 4	Bit 3	Bit 2	Bit 1	Bit 0
/PD57	/PD56	/PD55	/PD54	/PD53	/PD52	/PD51	/PD50

NOTE

The IOCB0 register is both readable and writable.

Bit 7 (/PD57): Control bit is used to enable the P57 pull-down pin
(applicable to EM78P260N only)

0 = Enable internal pull-down

1 = Disable internal pull-down

Bit 6 (/PD56): Control bit is used to enable the pull-down of the P56 pin
(applicable to EM78P260N only)

Bit 5 (/PD55): Control bit used to enable the P55 pull-down pin

Bit 4 (/PD54): Control bit used to enable the P54 pull-down pin

Bit 3 (/PD53): Control bit used to enable the P53 pull-down pin

Bit 2 (/PD52): Control bit used to enable the P52 pull-down pin

Bit 1 (/PD51): Control bit used to enable the P51 pull-down pin

Bit 0 (/PD50): Control bit used to enable the P50 pull-down pin

6.2.8 IOCC0 (Open-drain Control Register)

Bit 7	Bit 6	Bit 5	Bit 4	Bit 3	Bit 2	Bit 1	Bit 0
/OD67	/OD66	/OD65	/OD64	/OD63	/OD62	/OD61	/OD60

NOTE

The IOCC0 register is both readable and writable.

Bit 7 (/OD67): Control bit used to enable the P67 open-drain pin

0 = Enable open-drain output

1 = Disable open-drain output

Bit 6 (/OD66): Control bit used to enable the P66 open-drain pin

Bit 5 (/OD65): Control bit used to enable the P65 open-drain pin

Bit 4 (/OD64): Control bit used to enable the P64 open-drain pin

Bit 3 (/OD63): Control bit used to enable the P63 open-drain pin

Bit 2 (/OD62): Control bit used to enable the P62 open-drain pin

Bit 1 (/OD61): Control bit used to enable the P61 open-drain pin

Bit 0 (/OD60): Control bit used to enable the P60 open-drain pin



6.2.9 IOCD0 (Pull-high Control Register)

Bit 7	Bit 6	Bit 5	Bit 4	Bit 3	Bit 2	Bit 1	Bit 0
/PH57	/PH56	/PH55	/PH54	/PH53	/PH52	/PH51	/PH50

NOTE
The IOCD0 register is both readable and writable.

Bit 7 (/PH57): Control bit is used to enable the pull-high of the P57 pin (applicable to EM78P260N only).

0 = Enable internal pull-high

1 = Disable internal pull-high

Bit 6 (/PH56): Control bit used to enable the P56 pull-high pin (applicable to EM78P260N only)

Bit 5 (/PH55): Control bit used to enable the P55 pull-high pin.

Bit 4 (/PH54): Control bit used to enable the P54 pull-high pin.

Bit 3 (/PH53): Control bit used to enable the P53 pull-high pin.

Bit 2 (/PH52): Control bit used to enable the P52 pull-high pin.

Bit 1 (/PH51): Control bit used to enable the P51 pull-high pin.

Bit 0 (/PH50): Control bit used to enable the P50 pull-high pin.

6.2.10 IOCE0 (WDT Control & Interrupt Mask Registers 2)

Bit 7	Bit 6	Bit 5	Bit 4	Bit 3	Bit 2	Bit 1	Bit 0
WDTE	EIS	ADIE	CMPIE	PSWE	PSW2	PSW1	PSW0

Bit 7 (WDTE): Control bit used to enable Watchdog Timer

0 = Disable WDT

1 = Enable WDT

The WDTE is both readable and writable.

Bit 6 (EIS): Control bit is used to define the function of the P60 (/INT) pin

0 = P60, bidirectional I/O pin

1 = /INT, external interrupt pin. In this case, the I/O control bit of P60 (Bit 0 of IOC60) must be set to "1"

NOTE

- When EIS is "0," the path of /INT is masked. When EIS is "1," the status of /INT pin can also be read by way of reading Port 6 (R6). Refer to Fig. 6-3 (I/O Port and I/O Control Register Circuit for P60 (/INT)) under Section 6.4 (I/O Ports).
- EIS is both readable and writable.

- Bit 5 (ADIE):** ADIF interrupt enable bit
0 = disable ADIF interrupt
1 = enable ADIF interrupt
- Bit 4 (CMPIE):** CMPIF interrupt enable bit.
0 = disable CMPIF interrupt
1 = enable CMPIF interrupt
- Bit 3 (PSWE):** Prescaler enable bit for WDT
0 = prescaler disable bit, WDT rate is 1:1
1 = prescaler enable bit, WDT rate is set as Bit 2 ~ Bit 0
- Bit 2 ~ Bit 0 (PSW2 ~ PSW0):** WDT prescaler bits

PSW2	PSW1	PSW0	WDT Rate
0	0	0	1:2
0	0	1	1:4
0	1	0	1:8
0	1	1	1:16
1	0	0	1:32
1	0	1	1:64
1	1	0	1:128
1	1	1	1:256

6.2.11 IOCF0 (Interrupt Mask Register)

Bit 7	Bit 6	Bit 5	Bit 4	Bit 3	Bit 2	Bit 1	Bit 0
LPWTIE	HPWTIE	TCCIE	TCCBIE	TCCAIE	EXIE	ICIE	TCIE

NOTE

- The IOCF0 register is both readable and writable.
- Individual interrupt is enabled by setting its associated control bit in the IOCF0 and in IOCE0 Bit 4 & 5 to "1".
- Global interrupt is enabled by the ENI instruction and is disabled by the DISI instruction. Refer to Fig. 6-7 (Interrupt Input Circuit) under Section 6.6 (Interrupt).

- Bit 7 (LPWTIE):** LPWTIF interrupt enable bit
0 = Disable LPWTIF interrupt
1 = Enable LPWTIF interrupt
- Bit 6 (HPWTIE):** HPWTIF interrupt enable bit
0 = Disable HPWTIF interrupt
1 = Enable HPWTIF interrupt



- Bit 5 (TCCCIE):** TCCCIF interrupt enable bit
0 = Disable TCCCIF interrupt
1 = Enable TCCCIF interrupt
- Bit 4 (TCCBIE):** TCCBIF interrupt enable bit
0 = Disable TCCBIF interrupt
1 = Enable TCCBIF interrupt
- Bit 3 (TCCAIE):** TCCAIF interrupt enable bit
0 = Disable TCCAIF interrupt
1 = Enable TCCAIF interrupt
- Bit 2 (EXIE):** EXIF interrupt enable bit
0 = Disable EXIF interrupt
1 = Enable EXIF interrupt
- Bit 1 (ICIE):** ICIF interrupt enable bit
0 = Disable ICIF interrupt
1 = Enable ICIF interrupt
- Bit 0 (TCIE):** TCIF interrupt enable bit.
0 = Disable TCIF interrupt
1 = Enable TCIF interrupt

6.2.12 IOC51 (TCCA Counter)

IOC51 (TCCA) is an 8-bit clock counter. It can be read, written, and cleared on any reset condition and is an Up-counter.

NOTE

- *TCCA time-out period* $[1/Fosc \times (256 - TCCA \text{ cnt}) \times 1 \text{ (CLK=2)}]$
- *TCCA time-out period* $[1/Fosc \times (256 - TCCA \text{ cnt}) \times 2 \text{ (CLK=4)}]$

6.2.13 IOC61 (TCCB Counter)

8-bit clock counter for the least significant byte of **TCCBX (TCCB)**. It can be read, written, and cleared on any reset condition and is an Up-counter.

6.2.14 IOC71 (TCCBH/MSB Counter)

8-bit clock counter for the most significant byte of TCCBX (TCCBH). It can be read, written, and cleared on any reset condition.

When TCCBHE (IOC90) is "0," then TCCBH is disabled. When TCCBHE is "1," then TCCB is a 16-bit length counter.

NOTE

When TCCBH is Disabled:

- TCCB time-out period $[1/F_{osc} \times (256 - TCCB\ cnt) \times 1 (CLK=2)]$

- TCCB time-out period $[1/F_{osc} \times (256 - TCCB\ cnt) \times 2 (CLK=4)]$

When TCCBH is Enabled:

- TCCB time-out period $\{1/F_{osc} \times [65536 - (TCCBH \times 256 + TCCB\ cnt)] \times 1 (CLK=2)\}$

- TCCB time-out period $\{1/F_{osc} \times [65536 - (TCCBH \times 256 + TCCB\ cnt)] \times 2 (CLK=4)\}$

6.2.15 IOC81 (TCCC Counter)

IOC81 (TCCC) is an 8-bit clock counter that can be extended to 16-bit counter. It can be read, written, and cleared on any reset condition.

If HF (Bit 2 of IOCA0) = 1 and IRE (Bit 3 of IOCA0) = 1, TCCC counter scale uses the low-time segments of the pulse generated by Fcarrier frequency modulation (see Fig. 6-11 in Section 6.8.2, *Function Description*). Then TCCC value will be TCCC predict value.

When HP = 0 or IRE = 0, the TCCC is an UP Counter.

NOTE

Under TCCC UP Counter mode:

- TCCC timeout period $[1/F_{osc} \times scaler (IOCA0) \times (256 - TCCC\ cnt) \times 1 (CLK=2)]$

- TCCC timeout period $[1/F_{osc} \times scaler (IOCA0) \times (256 - TCCC\ cnt) \times 2 (CLK=4)]$

When HP = 1 and IRE = 1, TCCC counter scale uses the low-time segments of the pulse generated by the Fcarrier frequency modulation.

NOTE

Under IR mode:

- $F_{carrier} = FT / 2 \{ [1 + decimal\ TCCC\ Counter\ value\ (IOC81)] \times TCCC\ Scale\ (IOCA0) \}$

- FT is system clock: $FT = F_{osc}/1 (CLK=2)$

$$FT = F_{osc}/2 (CLK=4)$$



6.2.16 IOC91 (Low-Time Register)

The 8-bit Low-time register controls the active or low segment pulse.

The decimal value of its contents determines the number of oscillator cycles and verifies that the IR Out pin is active. The active period of the IR Out can be calculated as follows:

NOTE

- $Low\ time\ width = \{ [1 + decimal\ low\ time\ value\ (IOC91)] * Low\ time\ Scale\ (IOCB1) \} / FT$
- $FT\ is\ system\ clock: FT = Fosc/1\ (CLK=2)$
 $FT = Fosc/2\ (CLK=4)$

When an interrupt is generated by a Low-time down-counter underflow (if enabled), the next instruction will be fetched from address 015H (Low time).

6.2.17 IOCA1 (High Time Register)

The 8-bit High-time register controls the inactive or high period pulse.

The decimal value of its contents determines the number of oscillator cycles and verifies that the IR OUT pin is inactive. The inactive period of IR OUT can be calculated as follows:

NOTE

- $High\ time\ width = \{ [1 + decimal\ high\ time\ value\ (IOCA1)] * High\ time\ Scale\ (IOCB1) \} / FT$
- $FT\ is\ system\ clock: FT = Fosc/1\ (CLK=2)$
 $FT = Fosc/2\ (CLK=4)$

When an interrupt is generated by the High-time down counter underflow (when enabled), the next instruction will be fetched from address 012H (High time).

6.2.18 IOCB1 High/Low Time Scale Control Register

Bit 7	Bit 6	Bit 5	Bit 4	Bit 3	Bit 2	Bit 1	Bit 0
HTSE	HTS2	HTS1	HTS0	LTSE	LTS2	LTS1	LTS0

Bit 7 (HTSE): High-time scale enable bit

0 = scale disable bit, High-time rate is 1:1

1 = scale enable bit, High-time rate is set as Bit 6 ~ Bit 4.

Bit 6 ~ Bit 4 (HTS2 ~ HTS0): High-time scale bits:

HTS2	HTS1	HTS0	High-time Rate
0	0	0	1:2
0	0	1	1:4
0	1	0	1:8
0	1	1	1:16
1	0	0	1:32
1	0	1	1:64
1	1	0	1:128
1	1	1	1:256

Bit 3 (LTSE): Low-time scale enable bit

0 = scale disable bit, Low-time rate is 1:1

1 = scale enable bit, Low-time rate is set as Bit 2~Bit 0.

Bit 2 ~ Bit 0 (LTS2 ~ LTS0): Low-time scale bits:

LTS2	LTS1	LTS0	Low-time Rate
0	0	0	1:2
0	0	1	1:4
0	1	0	1:8
0	1	1	1:16
1	0	0	1:32
1	0	1	1:64
1	1	0	1:128
1	1	1	1:256

6.2.19 IOCC1 (TCC Prescaler Counter)

TCC prescaler counter can be read and written:

PST2	PST1	PST0	Bit 7	Bit 6	Bit 5	Bit 4	Bit 3	Bit 2	Bit 1	Bit 0	TCC Rate
0	0	0	-	-	-	-	-	-	-	V	1:2
0	0	1	-	-	-	-	-	-	V	V	1:4
0	1	0	-	-	-	-	-	V	V	V	1:8
0	1	1	-	-	-	-	V	V	V	V	1:16
1	0	0	-	-	-	V	V	V	V	V	1:32
1	0	1	-	-	V	V	V	V	V	V	1:64
1	1	0	-	V	V	V	V	V	V	V	1:128
1	1	1	V	V	V	V	V	V	V	V	1:256

V = valid value

The TCC prescaler counter is assigned to TCC (R1).

The contents of the IOCC1 register are cleared when one of the following occurs:

- a value is written to the TCC register
- a value is written to the TCC prescaler bits (Bits 3, 2, 1, 0 of CONT)
- power-on reset, /RESET
- WDT time out reset



6.3 TCC/WDT and Prescaler

There are two 8-bit counters available as prescalers that can be extended to 16-bit counter for the TCC and WDT respectively. The PST2 ~ PST0 bits of the CONT register are used to determine the ratio of the TCC prescaler, and the PWR2 ~ PWR0 bits of the IOCE0 register are used to determine the WDT prescaler. The prescaler counter is cleared by the instructions each time such instructions are written into TCC. The WDT and prescaler are cleared by the "WDTC" and "SLEP" instructions. Fig. 6-1 (next page) depicts the block diagram of TCC/WDT.

TCC (R1) is an 8-bit timer/counter. The TCC clock source can be internal clock or external signal input (edge selectable from the TCC pin). If TCC signal source is from the internal clock, the TCC will be incremented by 1 at every instruction cycle (without prescaler). Referring to Fig. 6-1, $CLK = F_{osc}/2$ or $CLK = F_{osc}/4$ is dependent to the Code Option bit <CLKS>. $CLK = F_{osc}/2$ if the CLKS bit is "0," and $CLK = F_{osc}/4$ if the CLKS bit is "1." If TCC signal source is from the external clock input, the TCC will be incremented by 1 at every falling edge or rising edge of the TCC pin. The TCC pin input time length (kept in High or Low level) must be greater than 1CLK.

NOTE

The internal TCC will stop running when sleep mode occurs. However, during AD conversion, when TCC is set to "SLEP" instruction, if the ADWE bit of the RE register is enabled, the TCC will keep on running

The watchdog timer is a free running on-chip RC oscillator. The WDT will keep on running even when the oscillator driver has been turned off (i.e., in sleep mode). During normal operation or sleep mode, a WDT time-out (if enabled) will cause the device to reset. The WDT can be enabled or disabled at any time during normal mode through software programming. Refer to WDTE bit of the IOCE0 register (Section 6.2.10 IOCE0 (WDT Control & Interrupt Mask Registers 2)). With no prescaler, the WDT time-out period is approximately 18ms¹ or 4.5ms².

¹ VDD=5V, WDT time-out period = 16.5ms ± 30%
VDD=3V, WDT time-out period = 18ms ± 30%

² VDD=5V, WDT time-out period = 4.2ms ± 30%
VDD=3V, WDT time-out period = 4.5ms ± 30%

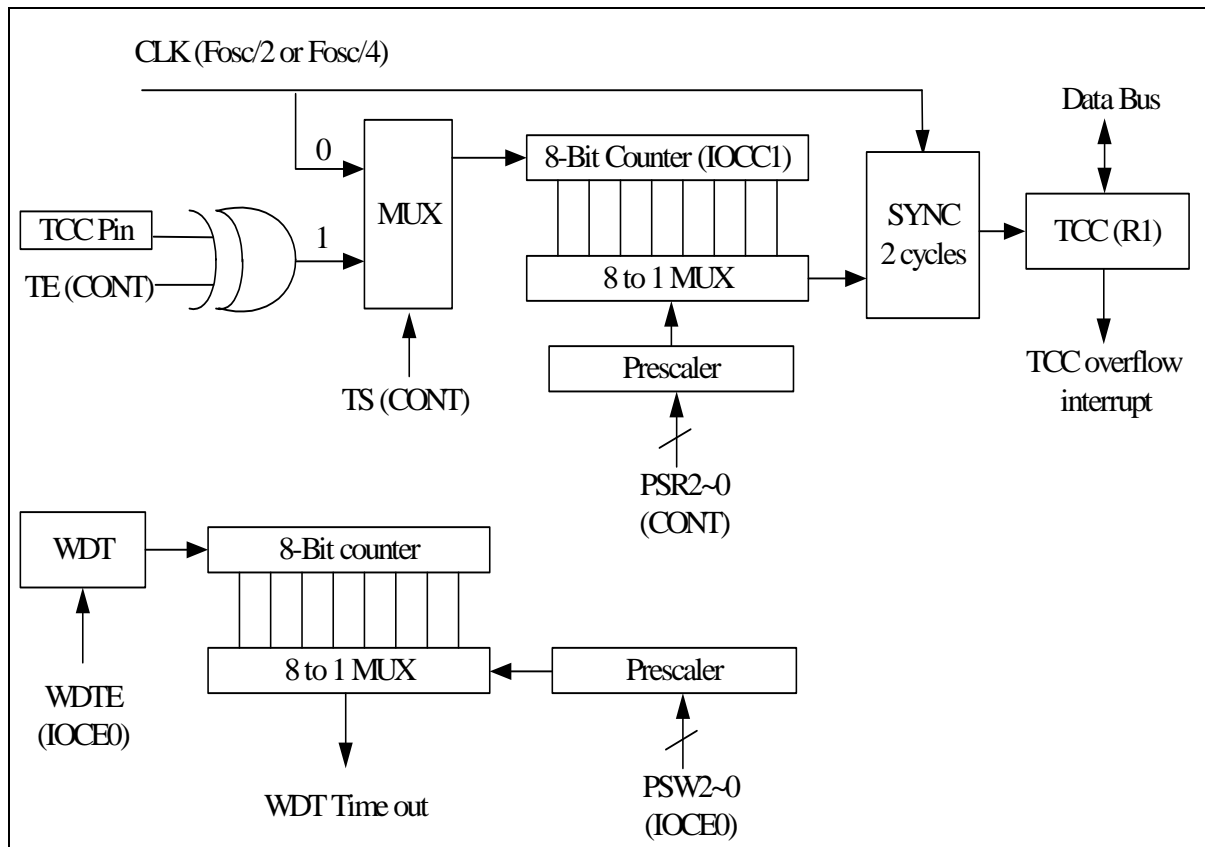
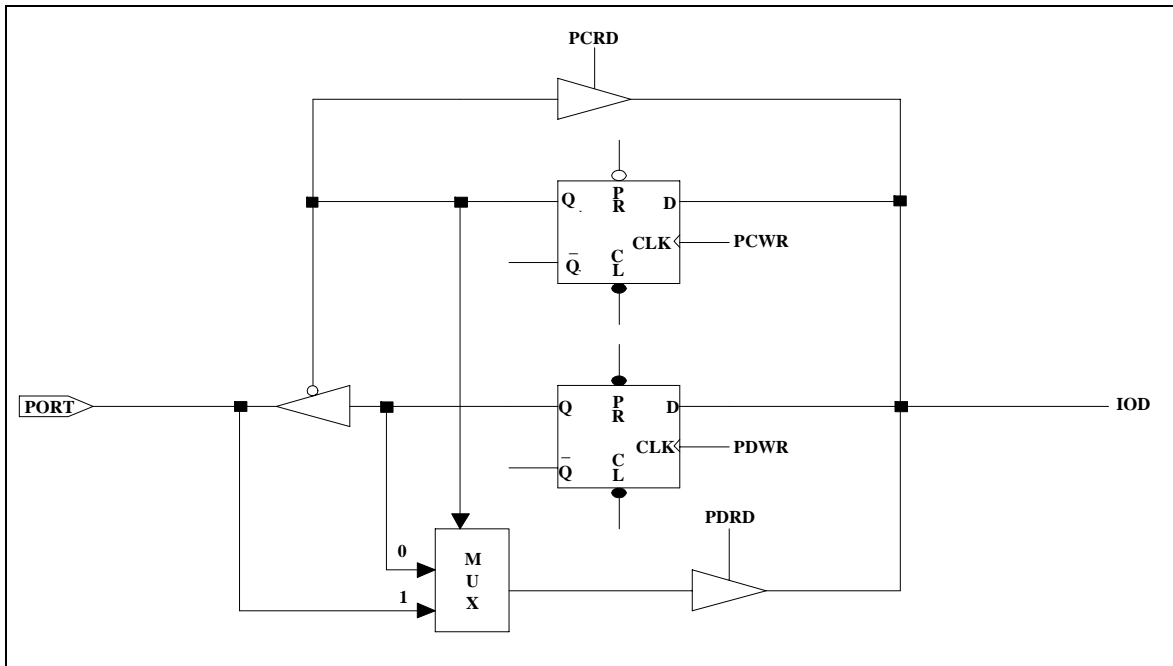

Fig 6-1 TCC and WDT Block Diagram

6.4 I/O Ports

The I/O registers (Port 5, Port 6, and Port 7) are bidirectional tri-state I/O ports. Port 5 is pulled-high and pulled-down internally by software. Likewise, P6 has its open-drain output through software. Port 5 has an input status changed interrupt (or wake-up) function. Each I/O pin can be defined as "input" or "output" pin by the I/O control register (IOC5 ~ IOC7). The I/O registers and I/O control registers are both readable and writable. The I/O interface circuits for Port 5, Port 6, and Port7 are illustrated in Figures 6-2, 6-3, 6-4, & 6-5 (see next page).



Note: Open-drain is not shown in the figure.

Fig 6-2 I/O Port and I/O Control Register Circuit for Port 6 and Port 7

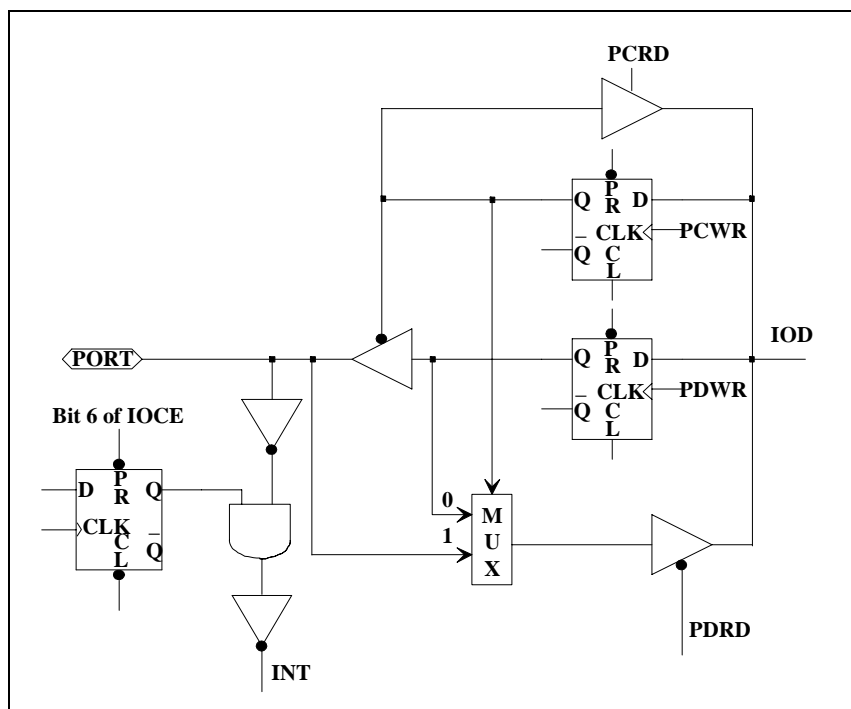

Note: Open-drain is not shown in the figure.

Fig 6-3 I/O Port and I/O Control Register Circuit for P60 (/INT)



6.4.1 Usage of Port 5 Input Change Wake-up/Interrupt Function

(1) Wake-up	(2) Wake-up and Interrupt
(a) Before Sleep	(a) Before Sleep
1. Disable WDT	1. Disable WDT
2. Read I/O Port 5 (MOV R5,R5)	2. Read I/O Port 5 (MOV R5,R5)
3. Execute "ENI" or "DISI"	3. Execute "ENI" or "DISI"
4. Enable wake-up bit (Set RE ICWE =1)	4. Enable wake-up bit (Set RE ICWE =1)
5. Execute "SLEP" instruction	5. Enable interrupt (Set IOCF0 ICIE =1)
(b) After wake-up	6. Execute "SLEP" instruction
→ Next instruction	(b) After wake-up
	1. IF "ENI" → Interrupt vector (006H)
	2. IF "DISI" → Next instruction
(3) Interrupt	
(a) Before Port 5 pin change	
1. Read I/O Port 5 (MOV R5,R5)	
2. Execute "ENI" or "DISI"	
3. Enable interrupt (Set IOCF0 ICIE =1)	
(b) After Port 5 pin changed (interrupt)	
1. IF "ENI" → Interrupt vector (006H)	
2. IF "DISI" → Next instruction	

6.5 Reset and Wake-up

6.5.1 Reset and Wake-up Operation

A Reset is initiated by one of the following events:

1. Power-on reset
2. /RESET pin input "low"
3. WDT time-out (if enabled)

The device is kept under reset condition for a period of approximately 18ms³ (except in LXT mode) after the reset is detected. When in LXT mode, the reset time is 500ms. Two choices (18ms³ or 4.5ms⁴) are available for WDT-time out period. Once a reset occurs, the following functions are performed (the initial address is 000h):

- The oscillator continues running, or will be started (if under sleep mode)
- The Program Counter (R2) is set to all "0"

³ VDD=5V, WDT Time-out period = 16.5ms ± 30%.
VDD=3V, WDT Time-out period = 18ms ± 30%.

⁴ VDD=5V, WDT Time-out period = 4.2ms ± 30%.
VDD=3V, WDT Time-out period = 4.5ms ± 30%.



- All I/O port pins are configured as input mode (high-impedance state)
- The Watchdog Timer and prescaler are cleared
- When power is switched on, the upper 3 bits of R3 is cleared
- The IOCB0 register bits are set to all "1"
- The IOCC0 register bits are set to all "1"
- The IOCD0 register bits are set to all "1"
- Bits 7, 5, and 4 of IOCE0 register is cleared
- Bit 5 and 4 of RE register is cleared
- RF and IOCF0 registers are cleared

Executing the "SLEP" instruction will assert the sleep (power down) mode. While entering into sleep mode, the Oscillator, TCC, TCCA, TCCB, and TCCC are stopped. The WDT (if enabled) is cleared but keeps on running.

During AD conversion, when "SLEP" instruction is set; the Oscillator, TCC, TCCA, TCCB, and TCCC keep on running. The WDT (if enabled) is cleared but keeps on running.

The controller can be awakened by:

- Case 1 External reset input on /RESET pin
- Case 2 WDT time-out (if enabled)
- Case 3 Port 5 input status changes (if ICWE is enabled)
- Case 4 Comparator output status changes (if CMPWE is enabled)
- Case 5 AD conversion completed (if ADWE enable)

The first two cases (1 & 2) will cause the EM78P260N to reset. The T and P flags of R3 can be used to determine the source of the reset (wake-up). Cases 3, 4, & 5 are considered the continuation of program execution and the global interrupt ("ENI" or "DISI" being executed) determines whether or not the controller branches to the interrupt vector following a wake-up. If ENI is executed before SLEP, the instruction will begin to execute from address 0x06 (Case 3), 0x0F (Case 4), and 0x0C (Case 5) after a wake-up. If DISI is executed before SLEP, the execution will restart from the instruction next to SLEP after a wake-up.

Only one of Cases 2 to 5 can be enabled before entering into sleep mode. That is:

- Case [a] If WDT is enabled before SLEP, all of the RE bit is disabled. Hence, the EM78P259N/260N can be awakened only with Case 1 or Case 2. Refer to the section on Interrupt (Section 6.6 below) for further details.
- Case [b] If Port 5 Input Status Change is used to wake -up EM78P259N/260N and the ICWE bit of RE register is enabled before SLEP, WDT must be disabled. Hence, the EM78P259N/260N can be awakened only with Case 3. Wake-up time is dependent on oscillator mode. Under RC mode, Wake-up time is 32 clocks (for oscillator stables). In High Crystal mode, Wake-up time is 2ms and 32clocks (for oscillator stables); and in low Crystal mode, Wake-up time is 500ms.



Case [c] If Comparator output status change is used to wake-up the EM78P259N/260N and CMPWE bit of the RE register is enabled before SLEP, WDT must be disabled by software. Hence, the EM78P259N/260N can be awakened only in Case 4. Wake-up time is dependent on the oscillator mode. In RC mode the Wake-up time is 32 clocks (for oscillator stables). In High Crystal mode, Wake-up time is 2 ms and 32 clocks (for stable oscillators); and in low Crystal mode, Wake-up time is 500ms.

Case [d] If AD conversion completed is used to wake-up the EM78P259N/260N and ADWE bit of RE register is enabled before SLEP, WDT must be disabled by software. Hence, the EM78P259N/260N can be awakened only in Case 5. The wake-up time is 15 TAD (ADC clock period).

If Port 5 Input Status Change Interrupt is used to wake up the EM78P259N/260N (as in Case [b] above), the following instructions must be executed before SLEP:

```
BC          R3, 7           ; Select Segment 0
MOV         A, @00xx1110b  ; Select WDT prescaler and Disable WDT
IOW        IOCE0
WDTC                          ; Clear WDT and prescaler
MOV         R5, R5         ; Read Port 5
ENI (or DISI)                ; Enable (or disable) global interrupt
MOV         A, @xxxxxx1xb  ; Enable Port 5 input change wake-up bit
MOV         RE
MOV         A, @xxxxxx1xb  ; Enable Port 5 input change interrupt
IOW        IOCF0
SLEP                          ; Sleep
```

Similarly, if the Comparator Interrupt is used to wake up the EM78P259N/260N (as in Case [c] above), the following instructions must be executed before SLEP:

```
BC          R3, 7           ; Select Segment 0
MOV         A, @xxx10XXXb  ; Select a comparator and P64 act as CO
                               pin
IOW        IOC80
MOV         A, @00x11110b  ; Select WDT prescaler and Disable WDT,
                               and enable comparator output status
                               change interrupt
IOW        IOCE0
WDTC                          ; Clear WDT and prescaler
ENI (or DISI)                ; Enable (or disable) global interrupt
MOV         A, @xxx0x1xxb  ; Enable comparator output status change
                               wake-up bit
MOV         RE
SLEP                          ; Sleep
```



6.5.1.1 Wake-up and Interrupt Modes Operation Summary

All categories under Wake-up and Interrupt modes are summarized below.

Signal	Sleep Mode	Normal Mode
INT Pin	N/A	DISI + IOCF0 (EXIE) Bit 2 = 1
		Next Instruction + Set RF (EXIF) = 1
		ENI + IOCF0 (EXIE) Bit 2 = 1
		Interrupt Vector (003H) + Set RF (EXIF) = 1
Port 5 Input Status Change	RE (ICWE) Bit 1 = 0, IOCF0 (ICIE) Bit 1 = 0 Oscillator, TCC, TCCX and IR/PWM are stopped. Port 5 input status changed wake-up is invalid.	IOCF0 (ICIE) Bit 1 = 0 Port 5 input status change interrupted is invalid
	RE (ICWE) Bit 1 = 0, IOCF0 (ICIE) Bit 1 = 1 Set RF (ICIF) = 1, Oscillator, TCC, TCCX and IR/PWM are stopped. Port 5 input status changed wake-up is invalid.	N/A
	RE (ICWE) Bit 1 = 1, IOCF0 (ICIE) Bit 1 = 0 Wake-up + Next Instruction Oscillator, TCC, TCCX and IR/PWM are stopped.	N/A
	RE (ICWE) Bit 1 = 1, DISI + IOCF0 (ICIE) Bit 1 = 1 Wake-up + Next Instruction + Set RF (ICIF) = 1 Oscillator, TCC, TCCX and IR/PWM are stopped.	DISI + IOCF0 (ICIE) Bit 1 = 1 Next Instruction + Set RF (ICIF) = 1
	RE (ICWE) Bit 1 = 1, ENI + IOCF0 (ICIE) Bit 1 = 1 Wake-up + Interrupt Vector (006H) + Set RF (ICIF) = 1 Oscillator, TCC, TCCX and IR/PWM are stopped.	ENI + IOCF0 (ICIE) Bit 1 = 1 Interrupt Vector(006H)+ Set RF (ICIF) = 1
TCC Over Flow	N/A	DISI + IOCF0 (TCIE) Bit 0 = 1
		Next Instruction + Set RF (TCIF) = 1
		ENI + IOCF0 (TCIE) Bit 0 = 1
		Interrupt Vector (009H) + Set RF (TCIF) = 1
AD Conversion	RE (ADWE) Bit 3 = 0, IOCE0 (ADIE) Bit 5 = 0 Clear R9 (ADRUN) = 0, ADC is stopped, AD conversion wake-up is invalid. Oscillator, TCC, TCCX and IR/PWM are stopped.	IOCE0 (ADIE) Bit 5 = 0 AD conversion interrupted is invalid
	RE (ADWE) Bit 3 = 0, IOCE0 (ADIE) Bit 5 = 1 Set RF (ADIF) = 1, R9 (ADRUN)=0, ADC is stopped, AD conversion wake-up is invalid. Oscillator, TCC, TCCX and IR/PWM are stopped.	N/A
	RE (ADWE) Bit 3 = 1, IOCE0 (ADIE) Bit 5 = 0 Wake-up + Next Instruction, Oscillator, TCC, TCCX and IR/PWM keep on running. Wake-up when ADC is completed.	N/A
	RE (ADWE) Bit 3 = 1, DISI + IOCE0 (ADIE) Bit 5 = 1 Wake-up + Next Instruction + RE (ADIF) = 1, Oscillator, TCC, TCCX and IR/PWM keep on running. Wake-up when ADC is completed.	DISI + IOCE0 (ADIE) Bit 5 = 1 Next Instruction + RE (ADIF) = 1
	RE (ADWE) Bit 3 = 1, ENI + IOCE0 (ADIE) Bit 5 = 1 Wake-up + Interrupt Vector (00CH) + RE (ADIF) = 1, Oscillator, TCC, TCCX and IR/PWM keep on running. Wake-up when ADC completed.	ENI + IOCE0 (ADIE) Bit 5 = 1 Interrupt Vector (00CH) + Set RE (ADIF) = 1



Signal	Sleep Mode	Normal Mode	
Comparator (Comparator Output Status Change)	RE (CMPWE) Bit 2 = 0, IOCE0 (CMPIE) Bit 4 = 0 Comparator output status changed wake-up is invalid. Oscillator, TCC, TCCX and IR/PWM are stopped.	IOCF0 (CMPIE) Bit 4 = 0 Comparator output status change interrupted is invalid.	
	RE (CMPWE) Bit 2 = 0, IOCE0 (CMPIE) Bit 4 = 1 Set RE (CMPIF) = 1, Comparator output status changed wake-up is invalid. Oscillator, TCC, TCCX and IR/PWM are stopped.	N/A	
	RE (CMPWE) Bit 2 = 1, IOCE0 (CMPIE) Bit 4 = 0 Wake-up + Next Instruction, Oscillator, TCC, TCCX and IR/PWM are stopped.	N/A	
	RE (CMPWE) Bit 2 = 1, DISI + IOCE0 (CMPIE) Bit 4 = 1 Wake-up + Next Instruction + Set RE (CMPIF) = 1, Oscillator, TCC, TCCX and IR/PWM are stopped.	DISI + IOCE0 (CMPIE) Bit 4 = 1 Next Instruction + Set RE (CMPIF) = 1	
	RE (CMPWE) Bit 2 = 1, ENI + IOCE0 (CMPIE) Bit 4 = 1 Wake-up + Interrupt Vector (00FH) + Set RE (CMPIF) = 1, Oscillator, TCC, TCCX and IR/PWM are stopped.	ENI + IOCE0 (CMPIE) Bit 4 = 1 Interrupt Vector (00FH) + Set RE (CMPIF) = 1	
	IR/PWM underflow interrupt (High-pulse width timer underflow interrupt)	N/A	DISI + IOCF0 (HPWTIF) Bit 6 = 1
			Next Instruction + Set RF (HPWTIE) = 1
			ENI + IOCF0 (HPWTIF) Bit 6 = 1
Interrupt Vector (012H) + Set RF (HPWTIE) = 1			
IR/PWM underflow interrupt (Low-pulse width timer underflow interrupt)	N/A	DISI + IOCF0 (LPWTIF) Bit 7 = 1	
		Next Instruction + Set RF (LPWTIE) = 1	
		ENI + IOCF0 (LPWTIF) Bit 7 = 1	
		Interrupt Vector (015H) + Set RF (LPWTIE) = 1	
TCCA Over Flow	N/A	DISI + IOCF0 (TCCAIE) Bit 3 = 1	
		Next Instruction + Set RF (TCCAIF) = 1	
		ENI + IOCF0 (TCCAIE) Bit 3 = 1	
		Interrupt Vector (018H) + Set RF (TCCAIF) = 1	
TCCB Over Flow	N/A	DISI + IOCF0 (TCCBIE) Bit 4 = 1	
		Next Instruction + Set RF (TCCBIF) = 1	
		ENI + IOCF0 (TCCBIE) Bit 4 = 1	
		Interrupt Vector (01BH) + Set RF (TCCBIF) = 1	
TCCC Over Flow	N/A	DISI + IOCF0 (TCCCIE) Bit 5 = 1	
		Next Instruction + Set RF (TCCCIF) = 1	
		ENI + IOCF0 (TCCCIE) Bit 5=1	
		Interrupt Vector (01EH) + Set RF (TCCCIF) = 1	
WDT Time Out IOCE (WDTE) Bit 7=1	Wake-up + Reset (Address 0x00)	Reset (address 0x00)	



6.5.1.2 Register Initial Values after a Reset

The following summarizes the initialized values for registers.

Address	Name	Reset Type	Bit 7	Bit 6	Bit 5	Bit 4	Bit 3	Bit 2	Bit 1	Bit 0		
N/A	IOC50	Bit Name	C57		C56		C55	C54	C53	C52	C51	C50
		Type	259 N	260 N	259 N	260 N	-	-	-	-	-	-
		Power-on	0	1	0	1	1	1	1	1	1	1
		/RESET and WDT	0	1	0	1	1	1	1	1	1	1
		Wake-up from Pin Change	0	P	0	P	P	P	P	P	P	P
N/A	IOC60	Bit Name	C67		C66		C65	C64	C63	C62	C61	C60
		Power-on	1	1	1	1	1	1	1	1	1	1
		/RESET and WDT	1	1	1	1	1	1	1	1	1	1
		Wake-up from Pin Change	P	P	P	P	P	P	P	P	P	P
N/A	IOC70	Bit Name	X	X	X	X	X	X	X	X	X	C70
		Power-on	0	0	0	0	0	0	0	0	0	1
		/RESET and WDT	0	0	0	0	0	0	0	0	0	1
		Wake-up from Pin Change	P	P	P	P	P	P	P	P	P	P
N/A	IOC80	Bit Name	X	X	CMPOUT	COS1	COS0	TCCAEN	TCCATS	TCCATE		
		Power-on	0	0	0	0	0	0	0	0	0	
		/RESET and WDT	0	0	0	0	0	0	0	0	0	
		Wake-up from Pin Change	P	P	P	P	P	P	P	P	P	
N/A	IOC90	Bit Name	TCCBHE	TCCBEN	TCCBTS	TCCBTE	X	TCCCEN	TCCCTS	TCCCTE		
		Power-on	0	0	0	0	0	0	0	0	0	
		/RESET and WDT	0	0	0	0	0	0	0	0	0	
		Wake-up from Pin Change	P	P	P	P	P	P	P	P	P	
N/A	IOCA0 (IR CR)	Bit Name	TCCCS0	TCCCS1	TCCCS2	TCCCS0	IRE	HF	LGP	IROUTE		
		Power-on	0	0	0	0	0	0	0	0	0	
		/RESET and WDT	0	0	0	0	0	0	0	0	0	
		Wake-up from Pin Change	P	P	P	P	P	P	P	P	P	
N/A	IOCB0 (PDCR)	Bit Name	/PD57	/PD56	/PD55	/PD54	/PD53	/PD52	/PD51	/PD50		
		Power-on	1	1	1	1	1	1	1	1	1	
		/RESET and WDT	1	1	1	1	1	1	1	1	1	
		Wake-up from Pin Change	P	P	P	P	P	P	P	P	P	
N/A	IOCC0 (ODCR)	Bit Name	/OD67	/OD66	/OD65	/OD64	/OD63	/OD62	/OD61	/OD60		
		Power-on	1	1	1	1	1	1	1	1	1	
		/RESET and WDT	1	1	1	1	1	1	1	1	1	
		Wake-up from Pin Change	P	P	P	P	P	P	P	P	P	



Address	Name	Reset Type	Bit 7	Bit 6	Bit 5	Bit 4	Bit 3	Bit 2	Bit 1	Bit 0
N/A	IOCD0 (PHCR)	Bit Name	/PH57	/PH56	/PH55	/PH54	/PH53	/PH52	/PH51	/PH50
		Power-on	1	1	1	1	1	1	1	1
		/RESET and WDT	1	1	1	1	1	1	1	1
		Wake-up from Pin Change	P	P	P	P	P	P	P	P
N/A	IOCE0	Bit Name	WDTC	EIS	ADIE	CMPIE	PSWE	PSW2	PSW1	PSW0
		Power-on	0	0	0	0	0	0	0	0
		/RESET and WDT	0	0	0	0	0	0	0	0
		Wake-up from Pin Change	P	P	P	P	P	P	P	P
N/A	IOCF0	Bit Name	LPWTIE	HPWTIE	TCCCIE	TCCBIE	TCCAIE	EXIE	ICIE	TCIE
		Power-on	0	0	0	0	0	0	0	0
		/RESET and WDT	0	0	0	0	0	0	0	0
		Wake-up from Pin Change	P	P	P	P	P	P	P	P
N/A	IOC51 (TCCA)	Bit Name	TCCA7	TCCA6	TCCA5	TCCA4	TCCA3	TCCA2	TCCA1	TCCA0
		Power-on	0	0	0	0	0	0	0	0
		/RESET and WDT	0	0	0	0	0	0	0	0
		Wake-up from Pin Change	P	P	P	P	P	P	P	P
N/A	IOC61 (TCCB)	Bit Name	TCCB7	TCCB6	TCCB5	TCCB4	TCCB3	TCCB2	TCCB1	TCCB0
		Power-on	0	0	0	0	0	0	0	0
		/RESET and WDT	0	0	0	0	0	0	0	0
		Wake-up from Pin Change	P	P	P	P	P	P	P	P
N/A	IOC71 (TCCBH)	Bit Name	TCCBH7	TCCBH6	TCCBH5	TCCBH4	TCCBH3	TCCBH2	TCCBH1	TCCBH0
		Power-on	0	0	0	0	0	0	0	0
		/RESET and WDT	0	0	0	0	0	0	0	0
		Wake-up from Pin Change	P	P	P	P	P	P	P	P
N/A	IOC81 (TCCC)	Bit Name	TCCC7	TCCC6	TCCC5	TCCC4	TCCC3	TCCC2	TCCC1	TCCC0
		Power-On	0	0	0	0	0	0	0	0
		/RESET and WDT	0	0	0	0	0	0	0	0
		Wake-up from Pin Change	P	P	P	P	P	P	P	P
N/A	IOC91 (LTR)	Bit Name	LTR7	LTR6	LTR5	LTR4	LTR3	LTR2	LTR1	LTR0
		Power-on	0	0	0	0	0	0	0	0
		/RESET and WDT	0	0	0	0	0	0	0	0
		Wake-up from Pin Change	P	P	P	P	P	P	P	P



Address	Name	Reset Type	Bit 7	Bit 6	Bit 5	Bit 4	Bit 3	Bit 2	Bit 1	Bit 0
N/A	IOCA1 (HTR)	Bit Name	HTR7	HTR6	HTR5	HTR4	HTR3	HTR2	HTR1	HTR0
		Power-on	0	0	0	0	0	0	0	0
		/RESET and WDT	0	0	0	0	0	0	0	0
		Wake-up from Pin Change	P	P	P	P	P	P	P	P
N/A	IOCB1 (HLTS)	Bit Name	HTSE	HTS2	HTS1	HTS0	LTSE	LTS2	LTS1	LTS0
		Power-on	0	0	0	0	0	0	0	0
		/RESET and WDT	0	0	0	0	0	0	0	0
		Wake-up from Pin Change	P	P	P	P	P	P	P	P
N/A	IOCC1 (TCCPC)	Bit Name	TCCPC7	TCCPC6	TCCPC5	TCCPC4	TCCPC3	TCCPC2	TCCPC1	TCCPC0
		Power-on	0	0	0	0	0	0	0	0
		/RESET and WDT	0	0	0	0	0	0	0	0
		Wake-up from Pin Change	P	P	P	P	P	P	P	P
N/A	CONT	Bit Name	INTE	INT	TS	TE	PSTE	PST2	PST1	PST0
		Power-on	1	0	1	1	0	0	0	0
		/RESET and WDT	1	0	1	1	0	0	0	0
		Wake-up from Pin Change	P	P	P	P	P	P	P	P
0x00	R0(IAR)	Bit Name	–	–	–	–	–	–	–	–
		Power-on	U	U	U	U	U	U	U	U
		/RESET and WDT	P	P	P	P	P	P	P	P
		Wake-up from Pin Change	P	P	P	P	P	P	P	P
0x01	R1(TCC)	Bit Name	–	–	–	–	–	–	–	–
		Power-on	0	0	0	0	0	0	0	0
		/RESET and WDT	0	0	0	0	0	0	00	0
		Wake-up from Pin Change	P	P	P	P	P	P	P	P
0x02	R2(PC)	Bit Name	–	–	–	–	–	–	–	–
		Power-on	0	0	0	0	0	0	0	0
		/RESET and WDT	0	0	0	0	0	0	0	0
		Wake-up from Pin Change	Jump to address 0x06 or continue to execute next instruction							
0x03	R3(SR)	Bit Name	RST	IOCS	PS0	T	P	Z	DC	C
		Power-on	0	0	0	1	1	U	U	U
		/RESET and WDT	0	0	0	T	t	P	P	P
		Wake-up from Pin Change	P	P	P	T	t	P	P	P



Address	Name	Reset Type	Bit 7	Bit 6	Bit 5	Bit 4	Bit 3	Bit 2	Bit 1	Bit 0
0x04	R4(RSR)	Bit Name	X	BS	X	X	X	X	X	X
		Power-on	0	0	U	U	U	U	U	U
		/RESET and WDT	0	0	P	P	P	P	P	P
		Wake-up from Pin Change	0	P	P	P	P	P	P	P
0x05	R5	Bit Name	P57	P56	P55	P54	P53	P52	P51	P50
		Power-on	1	1	1	1	1	1	1	1
		/RESET and WDT	1	1	1	1	1	1	1	1
		Wake-up from Pin Change	P	P	P	P	P	P	P	P
0x06	R6	Bit Name	P67	P66	P65	P64	P63	P62	P61	P60
		Power-on	1	1	1	1	1	1	1	1
		/RESET and WDT	1	1	1	1	1	1	1	1
		Wake-up from Pin Change	P	P	P	P	P	P	P	P
0x7	R7	Bit Name	–	–	–	–	–	–	–	P70
		Power-on	0	0	0	0	0	0	0	1
		/RESET and WDT	0	0	0	0	0	0	0	1
		Wake-up from Pin Change	P	P	P	P	P	P	P	P
0x8	R8 (AISR)	Bit Name	–	–	–	–	ADE3	ADE2	ADE1	ADE0
		Power-on	0	0	0	0	0	0	0	0
		/RESET and WDT	0	0	0	0	0	0	0	0
		Wake-up from Pin Change	0	0	0	0	P	P	P	P
0x9	R9 (ADCON)	Bit Name	VREFS	CKR1	CKR0	ADRUN	ADPD	–	ADIS1	ADIS0
		Power-on	0	0	0	0	0	0	0	0
		/RESET and WDT	0	0	0	0	0	0	0	0
		Wake-up from Pin Change	P	P	P	P	P	0	P	P
0xA	RA (ADOC)	Bit Name	CALI	SIGN	VOF[2]	VOF[1]	VOF[0]	–	–	–
		Power-on	0	0	0	0	0	0	0	0
		/RESET and WDT	0	0	0	0	0	0	0	0
		Wake-up from Pin Change	P	P	P	P	P	P	P	P
0xB	RB (ADDATA)	Bit Name	AD11	AD10	AD9	AD8	AD7	AD6	AD5	AD4
		Power-on	U	U	U	U	U	U	U	U
		/RESET and WDT	U	U	U	U	U	U	U	U
		Wake-up from Pin Change	P	P	P	P	P	P	P	P



6.5.2 The T and P Status under STATUS (R3) Register

A RESET condition is initiated by one of the following events:

1. Power-on reset
2. /RESET pin input "low"
3. WDT time-out (if enabled).

The values of RST, T, and P as listed in the table below, are used to check how the processor wakes up.

Reset Type	RST	T	P
Power-on	0	1	1
/RESET during Operating mode	0	*P	*P
/RESET wake-up during Sleep mode	0	1	0
WDT during Operating mode	0	0	1
WDT wake-up during Sleep mode	0	0	0
Wake-up on pin change during Sleep mode	1	1	0

*P: Previous status before reset

The following shows the events that may affect the status of T and P.

Event	RST	T	P
Power-on	0	1	1
WDT instruction	*P	1	1
WDT time-out	0	0	*P
SLEP instruction	*P	1	0
Wake-up on pin changed during Sleep mode	1	1	0

Note: * P: Previous value before reset

6.6 Interrupt

The EM78P259N/260N has six interrupts as listed below:

1. TCC, TCCA, TCCB, TCCC overflow interrupt
2. Port 5 Input Status Change Interrupt
3. External interrupt [(P60, /INT) pin]
4. Analog to Digital conversion completed
5. IR/PWM underflow interrupt
6. When the comparators status changes

Before the Port 5 Input Status Change Interrupt is enabled, reading Port 5 (e.g. "MOV R5,R5") is necessary. Each Port 5 pin will have this feature if its status changes. The Port 5 Input Status Change Interrupt will wake-up the EM78P259N/260N from the sleep mode if it is enabled prior to going into the sleep mode by executing SLEP instruction. When wake-up occurs, the controller will continue to execute program in-line if the global interrupt is disabled. If enabled, the global interrupt will branch out to the interrupt vector 006H.



External interrupt equipped with digital noise rejection circuit (input pulse less than 8 system clocks time) is eliminated as noise. However, under Low XTAL oscillator (LXT) mode the noise rejection circuit will be disabled. Edge selection is possible with INTE of CONT. When an interrupt is generated by the External interrupt (when enabled), the next instruction will be fetched from address 003H. Refer to the Word 1 Bits 9 & 8 (Section 6.14.2, *Code Option Register (Word1)*) for digital noise rejection definition

RF and RE are the interrupt status register that records the interrupt requests in the relative flags/bits. IOCF0 and IOCE0 are interrupt mask registers. The global interrupt is enabled by the ENI instruction and is disabled by the DISI instruction. Once in the interrupt service routine, the source of an interrupt can be determined by polling the flag bits in RF. The interrupt flag bit must be cleared by instructions before leaving the interrupt service routine to avoid recursive interrupts.

The flag (except for the ICIF bit) in the Interrupt Status Register (RF) is set regardless of the ENI execution. Note that the result of RF will be the logic AND of RF and IOCF0 (refer to figure below). The RETI instruction ends the interrupt routine and enables the global interrupt (the ENI execution).

When an interrupt is generated by the Timer clock/counter (when enabled), the next instruction will be fetched from Address 009, 018, 01B, and 01EH (TCC, TCCA, TCCB, and TCCC respectively).

When an interrupt generated by the AD conversion is completed (when enabled), the next instruction will be fetched from Address 00CH.

When an interrupt is generated by the High time / Low time down counter underflow (when enabled), the next instruction will be fetched from Address 012 and 015H (High time and Low time respectively).

When an interrupt is generated by the Comparators (when enabled), the next instruction will be fetched from Address) 00FH (Comparator interrupt).

Before the interrupt subroutine is executed, the contents of ACC and the R3 and R4 registers will be saved by the hardware. If another interrupt occurs, the ACC, R3, and R4 will be replaced by the new interrupt. After the interrupt service routine is completed, the ACC, R3, and R4 registers are restored.

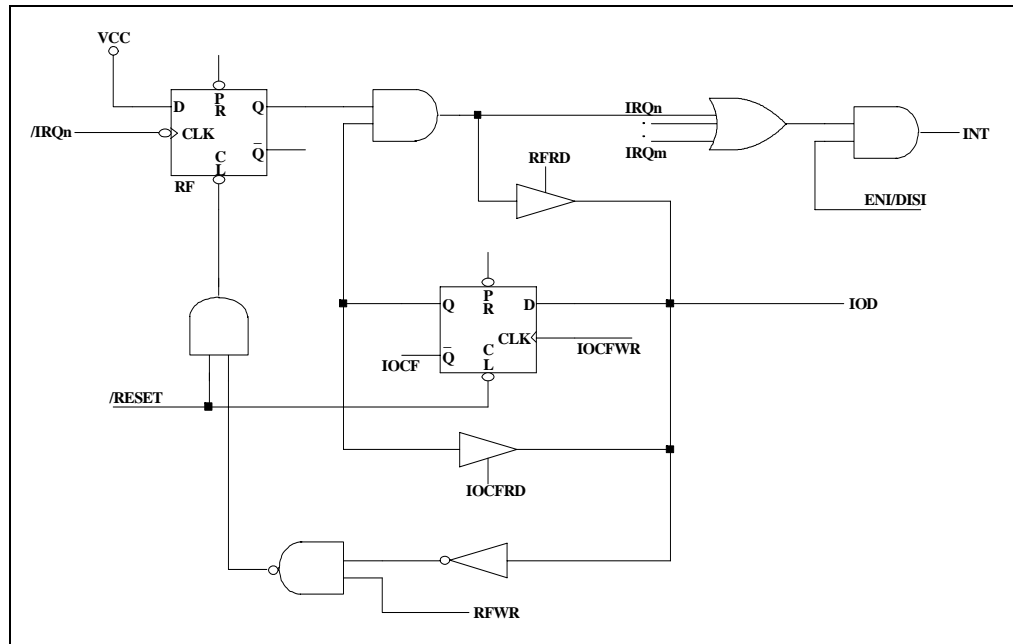

Fig 6-7 Interrupt Input Circuit

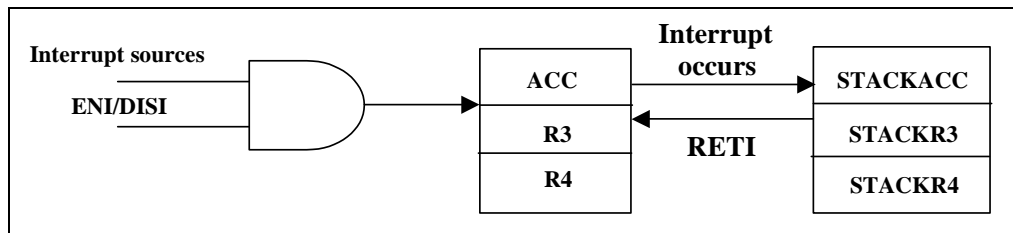

Fig 6-8 Interrupt Back-up Diagram

In EM78P259N/260N, each individual interrupt source has its own interrupt vector as depicted in the table below.

Interrupt Vector	Interrupt Status	Priority*
003H	External interrupt	1
006H	Port 5 pin change	2
009H	TCC overflow interrupt	3
00CH	AD conversion complete interrupt	4
00FH	Comparator interrupt	5
012H	High-pulse width timer underflow interrupt	6
015H	Low-pulse width timer underflow interrupt	7
018H	TCCA overflow interrupt	8
01BH	TCCB overflow interrupt	9
01EH	TCCC overflow interrupt	10

Note: *Priority: 1 = highest ; 10 = lowest priority

6.7 Analog-to-Digital Converter (ADC)

The analog-to-digital circuitry consist of a 4-bit analog multiplexer; three control registers (AISR/R8, ADCON/R9, & ADOC/RA), three data registers (ADDATA/RB, ADDATA1H/RC, & ADDATA1L/RD), and an ADC with 12-bit resolution as shown in the functional block diagram below. The analog reference voltage (Vref) and the analog ground are connected via separate input pins.

The ADC module utilizes successive approximation to convert the unknown analog signal into a digital value. The result is fed to the ADDATA, ADDATA1H, and ADDATA1L. Input channels are selected by the analog input multiplexer via the ADCON register Bits ADIS1 and ADIS0.

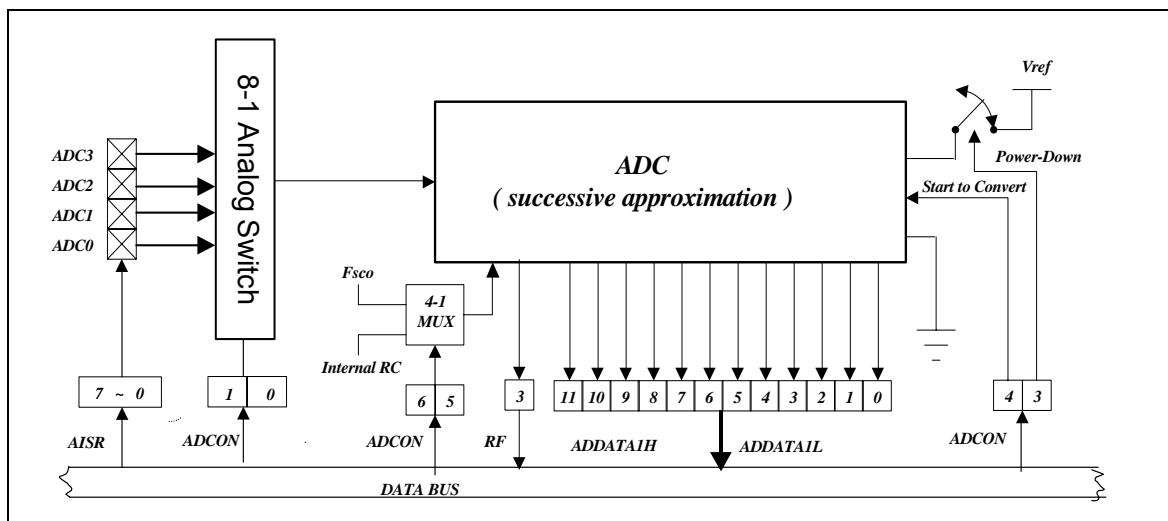

Fig 6-9 Analog-to-Digital Conversion Functional Block Diagram

6.7.1 ADC Control Register (AISR/R8, ADCON/R9, ADOC/RA)

6.7.1.1 R8 (AISR: ADC Input Select Register)

Bit 7	Bit 6	Bit 5	Bit 4	Bit 3	Bit 2	Bit 1	Bit 0
–	–	–	–	ADE3	ADE2	ADE1	ADE0

AISR register defines the Port 5 pins as analog inputs or as digital I/O, individually.

Bit 7 ~ 4: Not used

Bit 3 (ADE3): AD converter enable bit of P53 pin
0 = Disable ADC3, P53 acts as I/O pin
1 = Enable ADC3 acts as analog input pin

Bit 2 (ADE2): AD converter enable bit of P52 pin
0 = Disable ADC2, P53 acts as I/O pin
1 = Enable ADC2 acts as analog input pin



Bit 1 (ADE1): AD converter enable bit of P51 pin
 0 = Disable ADC1, P51 acts as I/O pin
 1 = Enable ADC1 acts as analog input pin

Bit 0 (ADE0): AD converter enable bit of P50 pin
 0 = Disable ADC0, P50 acts as I/O pin
 1 = Enable ADC0 acts as analog input pin

6.7.1.2 R9 (ADCON: AD Control Register)

Bit 7	Bit 6	Bit 5	Bit 4	Bit 3	Bit 2	Bit 1	Bit 0
VREFS	CKR1	CKR0	ADRUN	ADPD	-	ADIS1	ADIS0

ADCON register controls the operation of the AD conversion and decides which pin should be currently active.

Bit 7(VREFS): The input source of the ADC Vref
 0 = The ADC Vref is connected to Vdd (default value), and the P54/VREF pin carries out the P54 function
 1 = The ADC Vref is connected to P54/VREF

NOTE

*The P54/TCC/VREF pin cannot be applied to TCC and VREF at the same time. IF P54/TCC/VREF acts as VREF analog input pin, then CONT Bit 5 (TS) must be "0".
 The P54/TCC/VREF pin priority is as follows:*

P54/TCC/VREF Pin Priority		
High	Medium	Low
VREF	TCC	P54

Bit 6 ~ Bit 5 (CKR1 ~ CKR0): The ADC prescaler oscillator clock rate

- 00 = 1: 16 (default value)
- 01 = 1: 4
- 10 = 1: 64
- 11 = 1: WDT ring oscillator frequency

CKR1:CKR0	Operation Mode	Max. Operation Frequency
00	Fsco/16	4 MHz
01	Fsco/4	1 MHz
10	Fsco/64	16MHz
11	Internal RC	-



Bit 4 (ADRUN): ADC starts to RUN

1 = an AD conversion is started. This bit can be set by software.

0 = reset on completion of the conversion. This bit cannot be reset though software.

Bit 3 (ADPD): ADC Power-down mode.

1 = ADC is operating

0 = switch off the resistor reference to save power even while the CPU is operating.

Bit 2: Not used

Bit 1 ~ Bit 0 (ADIS1 ~ ADIS0): Analog Input Select

00 = ADIN0/P50

01 = ADIN1/P51

10 = ADIN2/P52

11 = ADIN3/P53

These bits can only be changed when the ADIF bit and the ADRUN bit are both LOW.

6.7.1.3 RA (ADOC: AD Offset Calibration Register)

Bit 7	Bit 6	Bit 5	Bit 4	Bit 3	Bit 2	Bit 1	Bit 0
CALI	SIGN	VOF[2]	VOF[1]	VOF[0]	–	–	–

Bit 7 (CALI): Calibration enable bit for ADC offset

0 = Calibration disable

1 = Calibration enable

Bit 6 (SIGN): Polarity bit of offset voltage

0 = Negative voltage

1 = Positive voltage

Bit 5 ~ Bit 3 (VOF[2] ~ VOF[0]): Offset voltage bits.

VOF[2]	VOF[1]	VOF[0]	EM78P259N/260N	ICE259N
0	0	0	0LSB	0LSB
0	0	1	2LSB	1LSB
0	1	0	4LSB	2LSB
0	1	1	6LSB	3LSB
1	0	0	8LSB	4LSB
1	0	1	10LSB	5LSB
1	1	0	12LSB	6LSB
1	1	1	14LSB	7LSB

Bit 2 ~ Bit 0: Unimplemented, read as '0'



6.7.2 ADC Data Register (ADDATA/RB, ADDATA1H/RC, ADDATA1L/RD)

When the AD conversion is completed, the result is loaded to the ADDATA, ADDATA1H and ADDATA1L registers. The ADRUN bit is cleared, and the ADIF is set.

6.7.3 ADC Sampling Time

The accuracy, linearity, and speed of the successive approximation of AD converter are dependent on the properties of the ADC and the comparator. The source impedance and the internal sampling impedance directly affect the time required to charge the sample holding capacitor. The application program controls the length of the sample time to meet the specified accuracy. Generally speaking, the program should wait for $2\mu\text{s}$ for each $K\Omega$ of the analog source impedance and at least $2\mu\text{s}$ for the low-impedance source. The maximum recommended impedance for analog source is $10K\Omega$ at $V_{\text{dd}}=5\text{V}$. After the analog input channel is selected, this acquisition time must be done before the conversion is started.

6.7.4 AD Conversion Time

CKR1 and CKR0 select the conversion time (T_{ct}), in terms of instruction cycles. This allows the MCU to run at a maximum frequency without sacrificing the AD conversion accuracy. For the EM78P259N/260N, the conversion time per bit is about $4\mu\text{s}$. The table below shows the relationship between T_{ct} and the maximum operating frequencies.

CKR1:CKR0	Operation Mode	Max. Operation Frequency	Max. Conversion Rate/Bit	Max. Conversion Rate
00	Fsco/16	4 MHz	250kHz (4us)	$15 \times 4\mu\text{s} = 60\mu\text{s}$ (16.7kHz)
01	Fsco/4	1MHz	250kHz (4us)	$15 \times 4\mu\text{s} = 60\mu\text{s}$ (16.7kHz)
10	Fsco/64	16MHz	250kHz (4us)	$15 \times 4\mu\text{s} = 60\mu\text{s}$ (16.7kHz)
11	Internal RC	–	14kHz (71us)	$15 \times 71\mu\text{s} = 1065\mu\text{s}$ (0.938kHz)

NOTE

- Pin not used as an analog input pin can be used as a regular input or output pin.
- During conversion, do not perform output instruction to maintain precision for all of the pins.

6.7.5 ADC Operation during Sleep Mode

In order to obtain a more accurate ADC value and reduce power consumption, the AD conversion remains operational during sleep mode. As the SLEP instruction is executed, all the MCU operations will stop except for the Oscillator, TCC, TCCA, TCCB, TCCC and AD conversion.



The AD Conversion is considered completed as determined by:

1. ADRUN bit of R9 register is cleared (“0” value).
2. ADIF bit of RE register is set to “1”.
3. ADWE bit of the RE register is set to “1.” Wake-up from ADC conversion (where it remains in operation during sleep mode).
4. Wake-up and executes the next instruction if ADIE bit of IOCE0 is enabled and the “DISI” instruction is executed.
5. Wake-up and enters into Interrupt vector (address 0x00C) if ADIE bit of IOCE0 is enabled and the “ENI” instruction is executed.
6. Enters into Interrupt vector (address 0x00C) if ADIE bit of IOCE0 is enabled and the “ENI” instruction is executed.

The results are fed into the ADDATA, ADDATA1H, and ADDATA1L registers when the conversion is completed. If the ADIE is enabled, the device will wake up. Otherwise, the AD conversion will be shut off, no matter what the status of ADPD bit is.

6.7.6 Programming Process/Considerations

6.7.6.1 Programming Process

Follow these steps to obtain data from the ADC:

1. Write to the four bits (ADE3: ADE0) on the R8 (AISR) register to define the characteristics of R5 (digital I/O, analog channels, or voltage reference pin)
2. Write to the R9/ADCON register to configure the AD module:
 - a) Select the ADC input channel (ADIS1: ADIS0)
 - b) Define the AD conversion clock rate (CKR1: CKR0)
 - c) Select the VREFS input source of the ADC
 - d) Set the ADPD bit to 1 to begin sampling
3. Set the ADWE bit, if the wake-up function is employed
4. Set the ADIE bit, if the interrupt function is employed
5. Write “ENI” instruction, if the interrupt function is employed
6. Set the ADRUN bit to 1
7. Write “SLEP” instruction or Polling
8. Wait for wake-up, or for the ADRUN bit to be cleared to “0”, or for the interrupt flag (ADIF) to be set to “1,” or for an ADC interrupt to occur
9. Read the ADDATA or ADDATA1H and ADDATA1L conversion data registers. If the ADC input channel changes at this time, the ADDATA, ADDATA1H, and ADDATA1L values can be cleared to ‘0’.
10. Clear the interrupt flag bit (ADIF)



11. For the next conversion, go to Step 1 or Step 2 as required. At least 2 Tct is required before the next acquisition starts.

NOTE

In order to obtain accurate values, it is necessary to avoid any data transition on the I/O pins during AD conversion.

6.7.6.2 Sample Demo Programs

A. Define a General Register

```
R_0 == 0          ; Indirect addressing register
PSW == 3          ; Status register
PORT5 == 5
PORT6 == 6
R_E== 0XE        ; Interrupt status register
```

B. Define a Control Register

```
IOC50 == 0X5     ; Control Register of Port 5
IOC60 == 0X6     ; Control Register of Port 6
C_INT== 0XF      ; Interrupt Control Register
```

C. ADC Control Register

```
ADDATA == 0xB    ; The contents are the results of ADC
AISR == 0x08     ; ADC input select register
ADCON == 0x9     ; 7 6 5 4 3 2 1 0
                  ; VREFS CKR1 CKR0 ADRUN ADPD ADIS2 ADIS1 ADIS0
```

D. Define Bits in ADCON

```
ADRUN == 0x4     ; ADC is executed as the bit is set
ADPD == 0x3      ; Power Mode of ADC
```

E. Program Starts

```
ORG 0            ; Initial address
JMP INITIAL     ;

ORG 0x0C        ; Interrupt vector
JMP CLRRE
;
;
;(User program section)
;
CLRRE:
MOV A,RE
AND A, @0BXX0XXXXX ; To clear the ADIF bit, "X" by application
MOV RE,A
BS ADCON, ADRUN   ; To start to execute the next AD conversion
                  if necessary

RETI
INITIAL:
```



```
MOV A,@0B00000001 ; To define P50 as an analog input
MOV AISR,A
MOV A,@0B00001000 ; To select P50 as an analog input channel, and
                    AD power on
MOV ADCON,A ; To define P50 as an input pin and set clock
            rate at fosc/16

En_ADC:
MOV A, @0BXXXXXXX1 ; To define P50 as an input pin, and the others
IOW PORT5 ; are dependent on applications
MOV A, @0BXXXX1XXX ; Enable the ADWE wake-up function of ADC, "X"
                  by application

MOV RE,A
MOV A, @0BXXXX1XXX ; Enable the ADIE interrupt function of ADC,
                  "X" by application

IOW C_INT
ENI ; Enable the interrupt function

BS ADCON, ADRUN ; Start to run the ADC

; If the interrupt function is employed, the following three lines
; may be ignored

;If Sleep:
SLEP
;
;(User program section)
;

or
;If Polling:
POLLING:
JBC ADCON, ADRUN ; To check the ADRUN bit continuously;
JMP POLLING ; ADRUN bit will be reset as the AD conversion
            is completed

;
;(User program section)
;
```

6.8 Infrared Remote Control Application/PWM Waveform Generation

6.8.1 Overview

This LSI can easily output infrared carrier or PWM standard waveform. As illustrated below, the IR and PWM waveform generation function include an 8-bit down count timer/counter, high-time, low-time, and IR control register. The IROUT pin waveform is determined by IOCA0 (IR and TCCC scale control register), IOCB1 (high-time rate, low-time rate control register), IOC81 (TCCC counter), IOCA1 (high-time register), and IOC91 (low-time register).

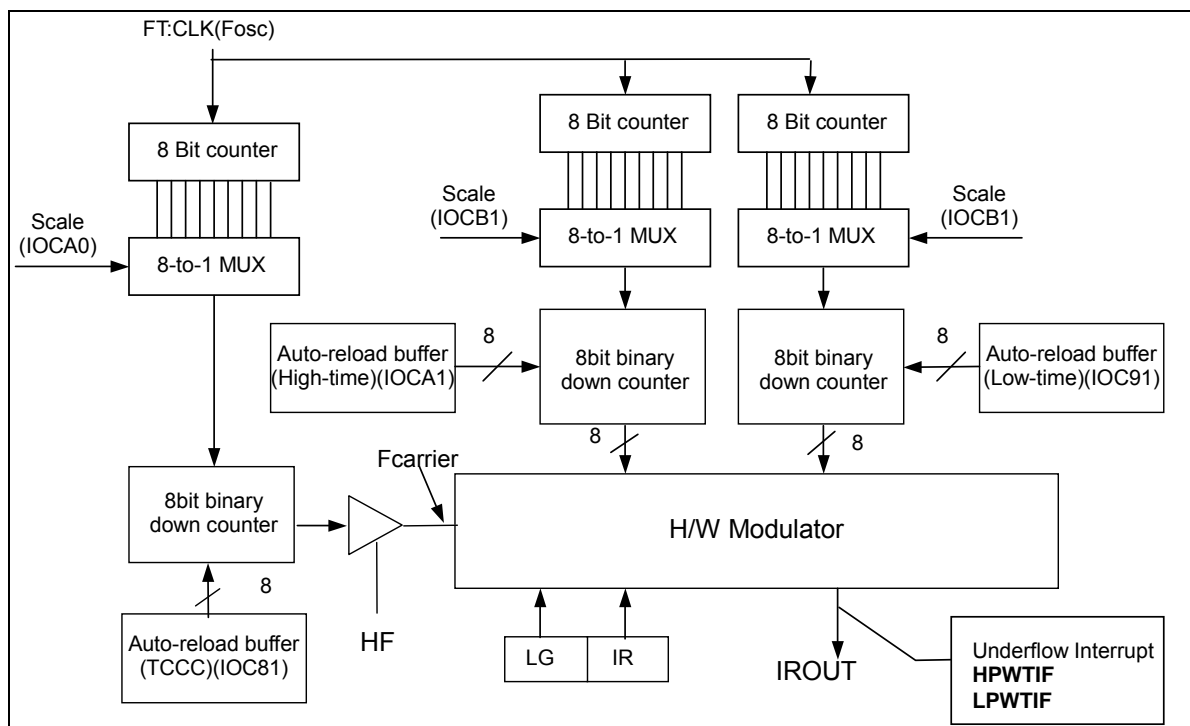

Fig 6-10 IR/PWM System Block Diagram

NOTE

Details of the $F_{carrier}$ high time width and low time width are explained below:

$$F_{carrier} = \frac{FT}{2} \{ [1 + \text{decimal TCCC Counter value (IOC81)}] * \text{TCCC Scale (IOCA0)} \}$$

$$\text{High time width} = \frac{\{ [1 + \text{decimal high-time value (IOCA1)}] * \text{High time Scale (IOCB1)} \}}{FT}$$

$$\text{Low time width} = \frac{\{ [1 + \text{decimal low-time value (IOC91)}] * \text{Low time Scale (IOCB1)} \}}{FT}$$

Where FT is the system clock $FT = F_{osc}/1$ (CLK=2)

$FT = F_{osc}/2$ (CLK=4)

When an interrupt is generated by the High time down counter underflow (when enabled), the next instruction will be fetched from address 018 and 01BH (High time and Low time respectively).

6.8.2 Function Description

The following figure shows **LGP=0** and **HF=1**. The IROUT waveform modulates the Fcarrier waveform at low-time segments of the pulse.

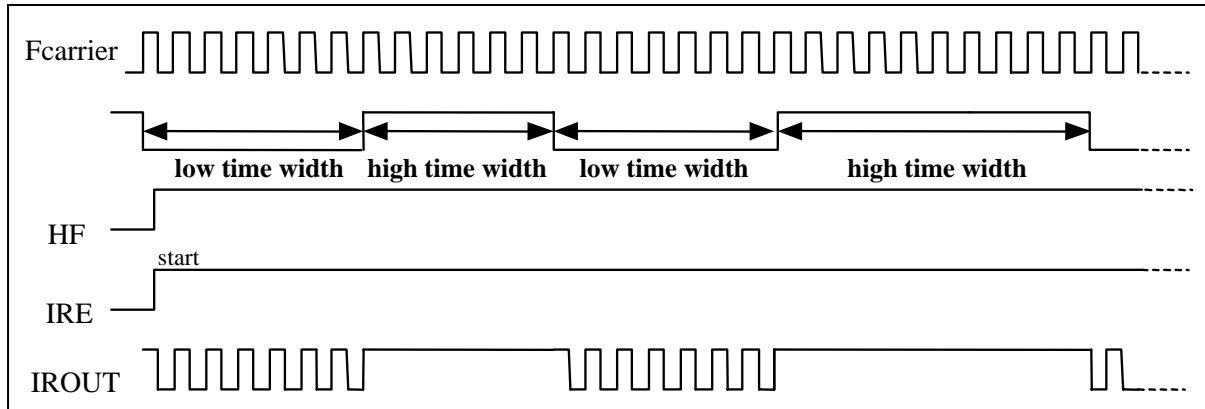

Fig 6-11a LGP=0, HF=1, IROUT Pin Output Waveform

The following figure shows **LGP=0** and **HF=0**. The IROUT waveform cannot modulate the Fcarrier waveform at low-time segments of the pulse. So IROUT waveform is determined by the high time width and low time width instead. This mode can produce standard PWM waveform

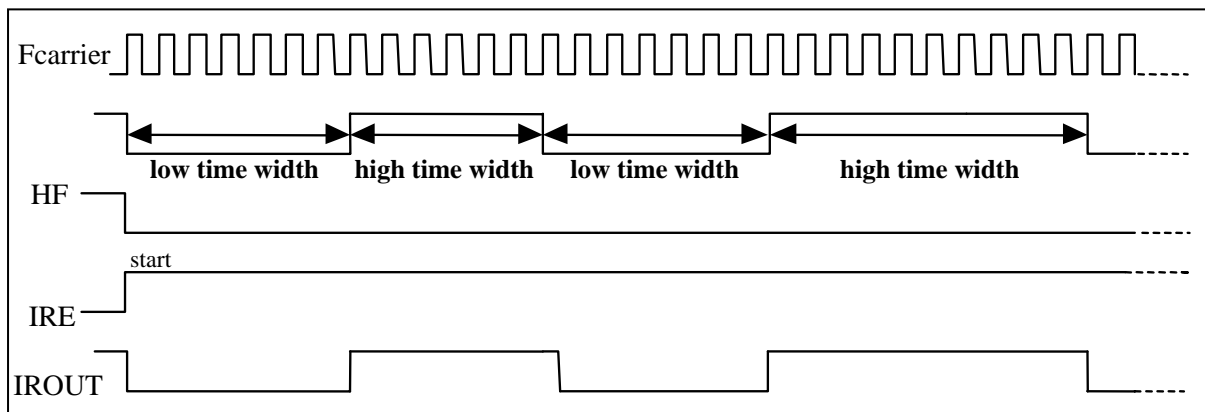

Fig 6-11b LGP=0, HF=0, IROUT Pin Output Waveform



The following figure shows **LGP=0** and **HF=1**. The IROUT waveform modulates the Fcarrier waveform at low-time segments of the pulse. When IRE goes low from high, the output waveform of IROUT will keep transmitting till high-time interrupt occurs.

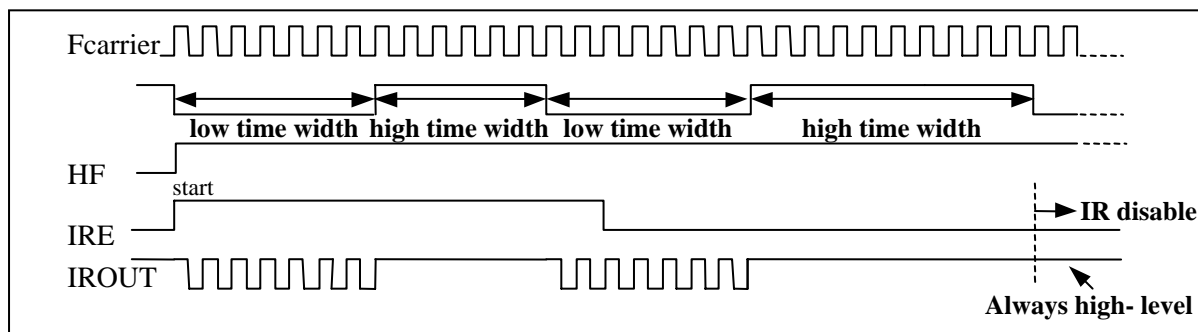

Fig 6-11c LGP=0, HF=1, When IRE goes Low from High, IROUT Pin Outputs Waveform

The following figure shows **LGP=0** and **HF=0**. The IROUT waveform cannot modulate the Fcarrier waveform at low-time segments of the pulse. So IROUT waveform is determined by high time width and low time width. This mode can produce standard PWM waveform when IRE goes low from high. The output waveform of IROUT will keep on transmitting "till high-time interrupt occurs.

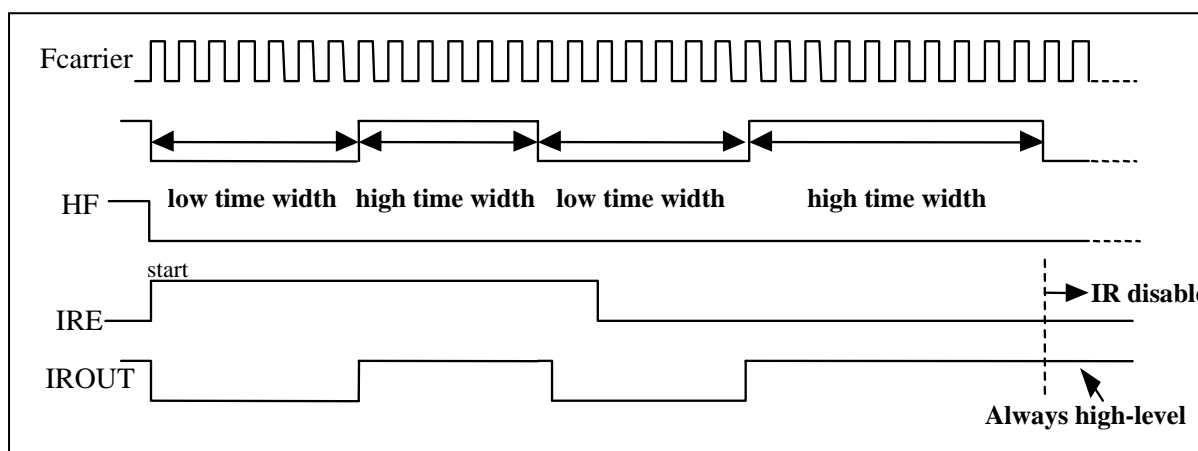

Fig 6-11d LGP=0, HF=0, When IRE goes Low from High, IROUT Pin Output Waveform

The following figure shows **LGP=1** and **HF=1**. When this bit is set to high level, the high-time segment of the pulse is ignored. So, IROUT waveform output is determined by low-time width.

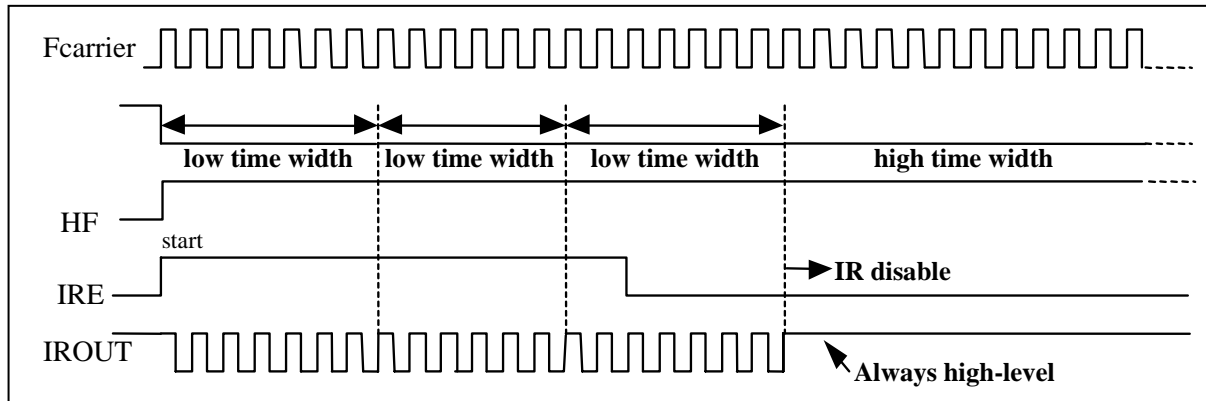

Fig 6-11e LGP=1 and HP=1, IROUT Pin Output Waveform

6.8.3 Programming the Related Registers

When defining IR/PWM, refer to the operation of the related registers as shown in the tables below.

IR/PWM Related Control Registers

Address	Name	Bit 7	Bit 6	Bit 5	Bit 4	Bit 3	Bit 2	Bit 1	Bit 0
0x09	IOC90	TCCBHE /0	TCCBEN/0	TCCBTS/0	TCCBTE/0	0	TCCCNEN/0	TCCCTS/0	TCCCTE/0
0X0A	IR CR /IOCA0	TCCCSE /0	TCCCS2/0	TCCCS1/0	TCCCS0/0	IRE/0	HF/0	LGP/0	IROUTE/0
0x0F	IMR /IOCF0	LPWTIE /0	HPWTIE/0	TCCCIE/0	TCCBIE/0	TCCAIE/0	EXIE/0	ICIE/0	TCIE/0
0X0B	HLTS /IOCB1	HTSE /0	HTS2/0	HTS1/0	HTS0/0	LTSE/0	LTS2/0	LTS1/0	LTS0/0

IR/PWM Related Status/Data Registers

Address	Name	Bit 7	Bit 6	Bit 5	Bit 4	Bit 3	Bit 2	Bit 1	Bit 0
0x0F	ISR/RF	LPWTIF/0	HPWTIF/0	TCCCIF/0	TCCBIF/0	TCCAIF/0	EXIF/0	ICIF/0	TCIF/0
0x06	TCCC /IOC81	TCCC7/0	TCCC6/0	TCCC5/0	TCCC4/0	TCCC3/0	TCCC2/0	TCCC1/0	TCCC0/0
0X09	LTR /IOC91	LTR7/0	LTR6/0	LTR5/0	LTR4/0	LTR3/0	LTR2/0	LTR1/0	LTR0/0
0X0A	HTR /IOCA1	HTR7/0	HTR6/0	HTR5/0	HTR4/0	HTR3/0	HTR2/0	HTR1/0	HTR0/0

6.9 Timer/Counter

6.9.1 Overview

Timer A (TCCA) is an 8-bit clock counter. Timer B (TCCB) is a 16-bit clock counter. Timer C (TCCC) is an 8-bit clock counter that can be extended to 16-bit clock counter with programmable scalars. TCCA, TCCB, and TCCC can be read and written to, and are cleared at every reset condition.

6.9.2 Function Description

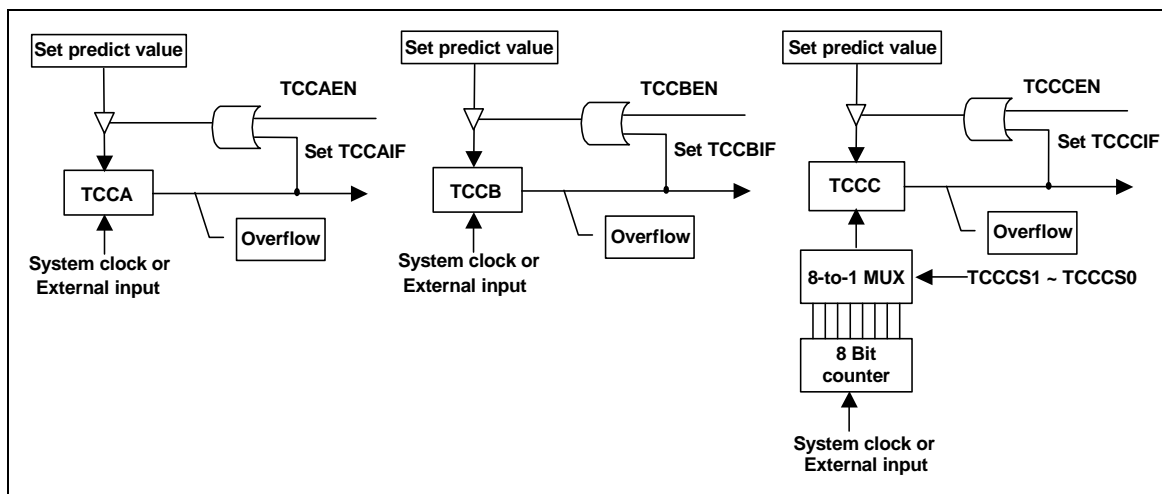

Fig 6.12 TIMER Block Diagram

Each signal and block of the above TIMER block diagram is described as follows:

TCCX: Timer A~C register. TCCX increases until it matches with zero, and then reload the predicted value. When writing a value to TCCX, the predicted value and TCCX value become the set value. When reading from TCCX, the value will be the TCCX direct value. When TCCXEN is enabled, the reload of the predicted value to TCCX, TCCXIE is also enabled. TCCXIF will be set at the same time. It is an up counter.

Under TCCA Counter (IOC51):

IOC51 (TCCA) is an 8-bit clock counter. It can be read, written, and cleared on any reset condition and is an UP Counter.

NOTE

- TCCA timeout period $[1/F_{osc} \times (256 - TCCA \text{ cnt}) \times 1 \text{ (CLK=2)}]$
- TCCA timeout period $[1/F_{osc} \times (256 - TCCA \text{ cnt}) \times 2 \text{ (CLK=4)}]$

Under TCCB Counter (IOC61):

An 8-bit clock counter is for the least significant byte of TCCBX (TCCB). It can be read, written, and cleared on any reset condition and is an UP Counter.



Under TCCBH / MSB Counter (IOC71):

An 8-bit clock counter is for the most significant byte of TCCBX (TCCBH). It can be read, written, and cleared on any reset condition.

When TCCBHE (IOC90) is "0," then TCCBH is disabled. When TCCBHE is "1," then TCCB is a 16-bit length counter.

NOTE

When TCCBH is Disabled:

TCCB timeout period $[1/Fosc \times (256 - TCCB \text{ cnt}) \times 1 (CLK=2)]$

TCCB timeout period $[1/Fosc \times (256 - TCCB \text{ cnt}) \times 2 (CLK=4)]$

When TCCBH is Enabled:

TCCB timeout period $\{1/Fosc \times [65536 - (TCCBH * 256 + TCCB \text{ cnt})] \times 1 (CLK=2)\}$

TCCB timeout period $\{1/Fosc \times [65536 - (TCCBH * 256 + TCCB \text{ cnt})] \times 2 (CLK=4)\}$

Under TCCC Counter (IOC81):

IOC81 (TCCC) is an 8-bit clock counter. It can be read, written, and cleared on any reset condition.

If HF (Bit 2 of IOCA0) = 1 and IRE (Bit 3 of IOCA0) = 1, TCCC counter scale uses the low-time segments of the pulse generated by Fcarrier frequency modulation (see Fig. 6-11 in Section 6.8.2, *Function Description*). Then the TCCC value will be the TCCC predicted value.

When HP = 0 or IRE = 0, the TCCC is an UP Counter.

NOTE

Under TCCC UP Counter Mode:

■ *TCCC time-out period* $[1/Fosc \times scaler (IOCA0) \times (256 - TCCC \text{ cnt}) \times 1 (CLK=2)]$

■ *TCCC time-out period* $[1/Fosc \times scaler (IOCA0) \times (256 - TCCC \text{ cnt}) \times 2 (CLK=4)]$

When HP = 1 and IRE = 1, the TCCC counter scale uses the low-time segments of the pulse generated by Fcarrier frequency modulation.

NOTE

Under IR Mode:

■ $F_{carrier} = FT / 2 \{ [1 + \text{decimal TCCC Counter value (IOC81)}] * TCCC \text{ Scale (IOCA0)} \}$

■ *FT is system clock:* $FT = Fosc / 1 (CLK=2)$

$FT = Fosc / 2 (CLK=4)$



6.9.3 Programming the Related Registers

When defining TCCX, refer to the operation of its related registers as shown in the tables below.

TCCX Related Control Registers:

Address	Name	Bit 7	Bit 6	Bit 5	Bit 4	Bit 3	Bit 2	Bit 1	Bit 0
0x08	IOC80	0	0	CPOUT/0	COS1/0	COS0/0	TCCAEN /0	TCCATS /0	TCCATE /0
0x09	IOC90	TCCBHE /0	TCCBEN /0	TCCBTS /0	TCCBTE /0	0	TCCCNEN /0	TCCCTS /0	TCCCTE /0
0x0A	IR CR /IOCA0	TCCCSE /0	TCCCS2 /0	TCCCS1/0	TCCCS0 /0	IRE/0	HF/0	LGP/0	IRROUTE/0
0x0F	IMR /IOCF0	LPWTE/0	HPWTE/0	TCCCIE/0	TCCBIE/0	TCCAIE/0	EXIE/0	ICIE/0	TCIE/0

Related TCCX Status/Data Registers:

Address	Name	Bit 7	Bit 6	Bit 5	Bit 4	Bit 3	Bit 2	Bit 1	Bit 0
0x0F	ISR/RF	LPWTF/0	HPWTF/0	TCCCIF/0	TCCBIF/0	TCCAIF/0	EXIF/0	ICIF/0	TCIF/0
0x05	TCCA /IOC51	TCCA7/0	TCCA6/0	TCCA5/0	TCCA4/0	TCCA3/0	TCCA2/0	TCCA1/0	TCCA0/0
0x06	TCCB /IOC61	TCCB7/0	TCCB6/0	TCCB5/0	TCCB4/0	TCCB3/0	TCCB2/0	TCCB1/0	TCCB0/0
0x07	TCCBH /IOC71	TCCBH7 /0	TCCBH6 /0	TCCBH5 /0	TCCBH4 /0	TCCBH3 /0	TCCBH2 /0	TCCBH1 /0	TCCBH0 /0
0x08	TCCC /IOC81	TCCC7/0	TCCC6/0	TCCC5/0	TCCC4/0	TCCC3/0	TCCC2/0	TCCC1/0	TCCC0/0

6.10 Comparator

EM78P259N/260N has one comparator which has two analog inputs and one output. The comparator can be employed to wake-up from the sleep mode. The Figure below shows the comparator circuit.

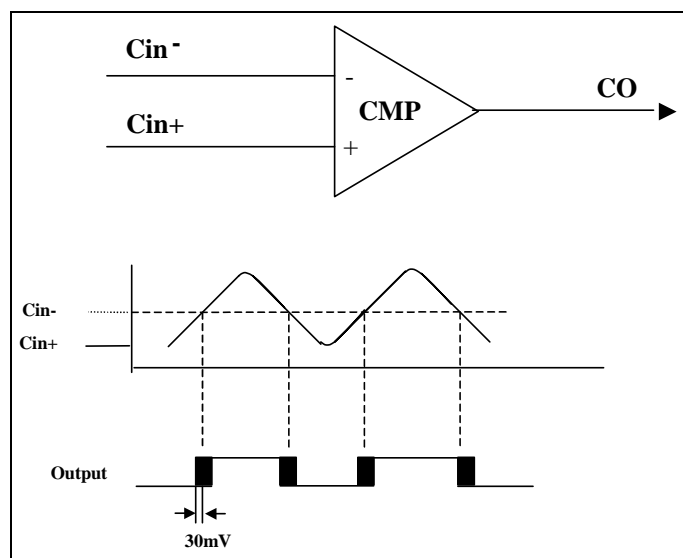

Fig 6.13 Comparator Operating Mode

6.10.1 External Reference Signal

The analog signal that is presented at Cin- compares to the signal at Cin+. The digital output (CO) of the comparator is adjusted accordingly by taking the following notes into considerations:

NOTE

- The reference signal must be between Vss and Vdd.
- The reference voltage can be applied to either pin of the comparator.
- Threshold detector applications may be of the same reference.
- The comparator can operate from the same or different reference sources.

6.10.2 Comparator Outputs

- The compared result is stored in the CMPOUT of IOC80.
- The comparator outputs are sent to CO (P64) through programming Bit 4 & Bit 3 <COS1, COS0> of the IOC80 register to <1,0>. See table under Section 6.2.4, *IOC80 (Comparator and TCCA Control Registers)* for Comparator/OP select bits function description.

The following figure shows the Comparator Output block diagram.

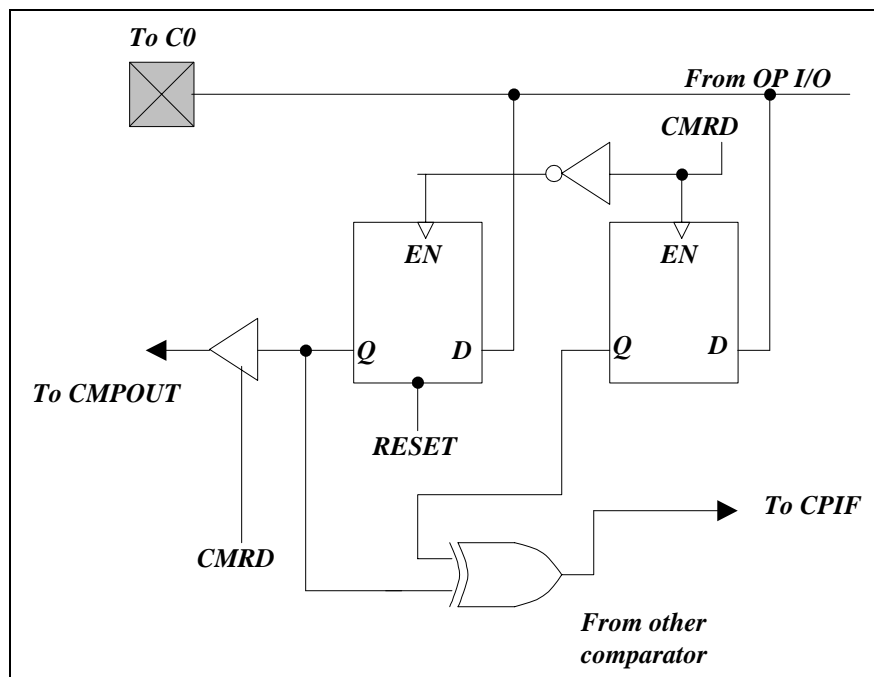

Fig 6-14 Comparator Output Configuration



6.10.3 Using a Comparator as an Operation Amplifier

The comparator can be used as an operation amplifier if a feedback resistor is externally connected from the input to the output. In this case, the Schmitt trigger can be disabled for power saving purposes, by setting Bit 4, Bit 3 <COS1, COS0> of the IOC80 register to <1, 1>. See table under Section 6.2.4, *IOC80 (Comparator and TCCA Control Registers)* for Comparator/OP select bits function description.

NOTE

Under Operation Amplifier:

- The CMPIE (IOCE0.4), CMPWE (RE.2), and CMPIF (RE.4) bits are invalid.
- The comparator interrupt is invalid.
- The comparator wake-up is invalid.

6.10.4 Comparator Interrupt

- CMPIE (IOCE0.4) must be enabled for the “ENI” instruction to take effect
- Interrupt is triggered whenever a change occurs on the comparator output pin
- The actual change on the pin can be determined by reading the Bit CMPOUT, IOC80 <5>.
- CMPIF (RE.4), the comparator interrupt flag, can only be cleared by software

6.10.5 Wake-up from Sleep Mode

- If the CMPWE bit of the RE register is set to “1,” the comparator remains active and the interrupt remains functional, even in Sleep mode.
- If a mismatch occurs, the change will wake up the device from Sleep mode.
- The power consumption should be taken into consideration for the benefit of energy conservation.
- If the function is unemployed during Sleep mode, turn off the comparator before entering into sleep mode.

The Comparator is considered completed as determined by:

1. COS1 and COS0 bits of IOC80 register setting selects Comparator.
2. CMPIF bit of RE register is set to “1”.
3. CMPWE bit of RE register is set to “1”. Wakes-up from Comparator (where it remains in operation during sleep mode)
4. Wakes-up and executes the next instruction, if CMPIE bit of IOCE0 is enabled and the “DISI” instruction is executed.
5. Wake-up and enters into Interrupt vector (address 0x00F), if ADIE bit of IOCE0 is enabled and the “ENI” instruction is executed
6. Enters into Interrupt vector (address 0x00F), if CMPIE bit of IOCE0 is enabled and the “ENI” instruction is executed.

6.11 Oscillator

6.11.1 Oscillator Modes

The EM78P259N/260N can be operated in four different oscillator modes, such as High Crystal oscillator mode (HXT), Low Crystal oscillator mode (LXT), External RC oscillator mode (ERC), and RC oscillator mode with Internal RC oscillator mode (IRC). You can select one of them by programming the OSC2, OCS1, and OSC0 in the CODE Option register.

The Oscillator modes defined by OSC2, OCS1, and OSC0 are described below.

Oscillator Modes	OSC2	OSC1	OSC0
ERC ¹ (External RC oscillator mode); P70/OSCO acts as P70	0	0	0
ERC ¹ (External RC oscillator mode); P70/OSCO acts as OSCO	0	0	1
IRC ² (Internal RC oscillator mode); P70/OSCO acts as P70	0	1	0
IRC ² (Internal RC oscillator mode); P70/OSCO acts as OSCO	0	1	1
LXT ³ (Low Crystal oscillator mode)	1	1	0
HXT ³ (High Crystal oscillator mode) (default)	1	1	1

Note: ¹ In ERC mode, OSCI is used as oscillator pin. OSCO/P70 is defined by code option Word 0 Bit 6 ~ Bit 4.

² In IRC mode, P55 is normal I/O pin. OSCO/P70 is defined by code option Word 0 Bit 6 ~ Bit 4.

³ In LXT and HXT modes; OSCI and OSCO are used as oscillator pins. These pins cannot and should not be defined as normal I/O pins.

NOTE

The transient point of the system frequency between HXT and LXY is 400kHz.

The maximum operating frequency limit of crystal/resonator at different VDDs, are as follows:

Conditions	VDD	Max. Freq. (MHz)
Two clocks	2.3	4
	3.0	8
	5.0	20



6.11.2 Crystal Oscillator/Ceramic Resonators (Crystal)

The EM78P259N/260N can be driven by an external clock signal through the OSCI pin as illustrated below.

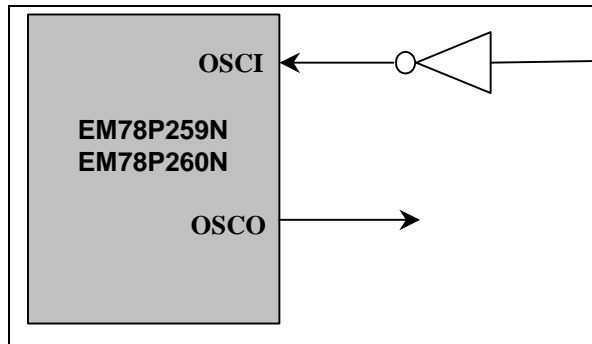

Fig 6-15 External Clock Input Circuit

In most applications, Pin OSCI and Pin OSCO can be connected with a crystal or ceramic resonator to generate oscillation. Fig. 6-16 below depicts such circuit. The same applies to the HXT mode and the LXT mode.

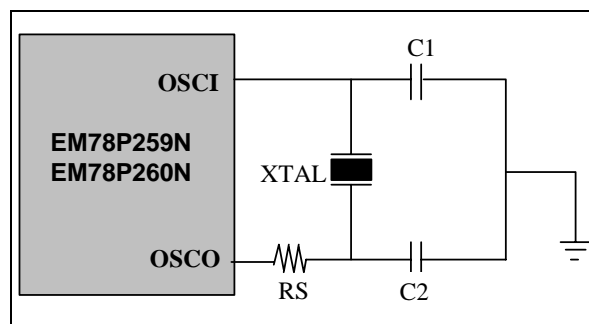

Fig 6-16 Crystal/Resonator Circuit

The following table provides the recommended values for C1 and C2. Since each resonator has its own attribute, you should refer to the resonator specifications for the appropriate values of C1 and C2. RS, a serial resistor, may be required for AT strip cut crystal or low frequency mode.

Capacitor selection guide for crystal oscillator or ceramic resonators:

Oscillator Type	Frequency Mode	Frequency	C1 (pF)	C2 (pF)
Ceramic Resonators	HXT	455kHz	100~150	100~150
		2.0 MHz	20~40	20~40
		4.0 MHz	10~30	10~30
Crystal Oscillator	LXT	32.768kHz	25	15
		100kHz	25	25
		200kHz	25	25
	HXT	455kHz	20~40	20~150
		1.0 MHz	15~30	15~30
		2.0 MHz	15	15
		4.0 MHz	15	15

Circuit diagrams for serial and parallel modes Crystal/Resonator:

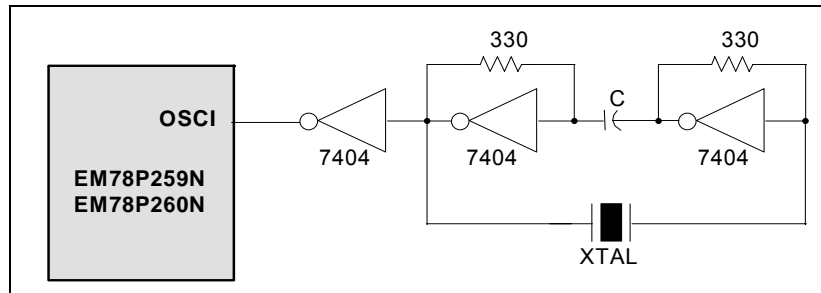

Fig 6-17 Serial Mode Crystal/Resonator Circuit Diagram

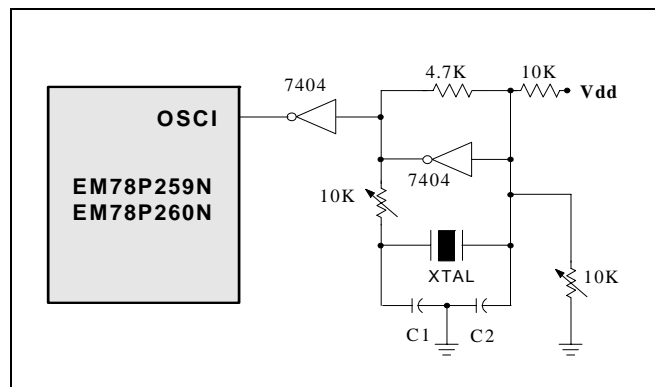

Fig 6-18 Parallel Mode Crystal/Resonator Circuit Diagram

6.11.3 External RC Oscillator Mode

For some applications that do not require precise timing calculation, the RC oscillator (Fig. 6-19 right) offers a cost-effective solution. Nevertheless, it should be noted that the frequency of the RC oscillator is influenced by the supply voltage, the values of the resistor (R_{ext}), the capacitor (C_{ext}), and even by the operation temperature. Moreover, the frequency also changes slightly from one chip to another due to manufacturing process variations.

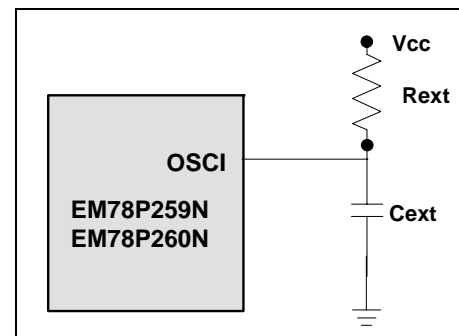

Fig 6-19 External RC Oscillator Mode Circuit

In order to maintain a stable system frequency, the values of the C_{ext} should be no less than 20pF, and that of R_{ext} should be no greater than 1M Ω . If the frequency cannot be kept within this range, the frequency can be affected easily by noise, humidity, and leakage.

The smaller the R_{ext} in the RC oscillator is, the faster its frequency will be. On the contrary, for very low R_{ext} values, for instance, 1 K Ω , the oscillator will become unstable because the NMOS cannot discharge the capacitance current correctly.



Based on the stated facts, it must be kept in mind that all supply voltage, operation temperature, the components of the RC oscillator, the package types, and the way the PCB is layout, have certain effect on the system frequency.

The RC Oscillator frequencies:

Cext	Rext	Average Fosc 5V,25°C	Average Fosc 3V, 25°C
20 pF	3.3k	3.5 MHz	3.2 MHz
	5.1k	2.5 MHz	2.3 MHz
	10k	1.30 MHz	1.25 MHz
	100k	140 KHz	140kHz
100 pF	3.3k	1.27 MHz	1.21 MHz
	5.1k	850kHz	820kHz
	10k	450kHz	450kHz
	100k	48kHz	50kHz
300 pF	3.3k	560kHz	540kHz
	5.1k	370kHz	360kHz
	10k	196kHz	192kHz
	100k	20kHz	20kHz

Note: 1. Measured on DIP packages
 2. Design reference only
 3. The frequency drift is $\pm 30\%$

6.11.4 Internal RC Oscillator Mode

EM78P259N/260N offers a versatile internal RC mode with default frequency value of 4MHz. Internal RC oscillator mode has other frequencies (1MHz, 8MHz, and 455kHz) that can be set by Code Option (Word 1), RCM1, and RCM0. The Table below describes the EM78P259N/260N internal RC drift with voltage, temperature, and process variation.

Internal RC Drift Rate (Ta=25°C, VDD=5V \pm 5%, VSS=0V)

Internal RC Frequency	Drift Rate			
	Temperature (-40°C ~+85°C)	Voltage (2.3V~5.5V)	Process	Total
4MHz	$\pm 10\%$	$\pm 5\%$	$\pm 4\%$	$\pm 19\%$
8MHz	$\pm 10\%$	$\pm 6\%$	$\pm 4\%$	$\pm 20\%$
1MHz	$\pm 10\%$	$\pm 5\%$	$\pm 4\%$	$\pm 19\%$
455MHz	$\pm 10\%$	$\pm 5\%$	$\pm 4\%$	$\pm 19\%$

Note: Theoretical values, for reference only. Actual values may vary depending on the actual process.

6.12 Power-on Considerations

Any microcontroller is not warranted to start operating properly before the power supply stabilizes in steady state. The EM78P259N/260N POR voltage range is 1.9 ~ 2.1V. Under customer application, when power is switched OFF, Vdd must drop below 1.9V and remains at OFF state for 10 μ s before power can be switched ON again. Subsequently, the EM78P259N/260N will reset and work normally. The extra external reset circuit will work well if Vdd rises fast enough (50ms or less). However, under critical applications, extra devices are still required to assist in solving power-on problems.

6.12.1 Programmable WDT Time-Out Period

The Option word (WDTPS) is used to define the WDT time-out period (18ms⁵ or 4.5ms⁶). Theoretically, the range is from 4.5ms or 18ms. For most crystal or ceramic resonators, the lower the operation frequency is, the longer is the required set-up time.

6.12.2 External Power-on Reset Circuit

The circuit shown in the following figure implements an external RC to produce a reset pulse. The pulse width (time constant) should be kept long enough to allow Vdd to reach the minimum operating voltage. This circuit is used when the power supply has a slow power rise time. Because the current leakage from the /RESET pin is about $\pm 5\mu$ A, it is recommended that R should not be greater than 40 K. This way, the voltage at Pin /RESET is held below 0.2V. The diode (D) acts as a short circuit at power-down. The "C" capacitor is discharged rapidly and fully. Rin, the current-limited resistor, prevents high current discharge or ESD (electrostatic discharge) from flowing into Pin /RESET.

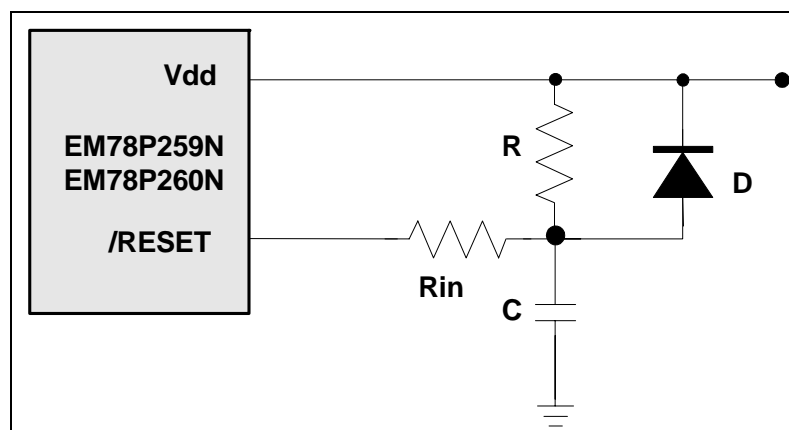

Fig 6-20 External Power-on Reset Circuit

⁵ VDD=5V, WDT time-out period = 16.5ms \pm 30%.
VDD=3V, WDT time-out period = 18ms \pm 30%.

⁶ VDD=5V, WDT time-out period = 4.2ms \pm 30%.
VDD=3V, WDT time-out period = 4.5ms \pm 30%.



6.12.3 Residual Voltage Protection

When the battery is replaced, device power (Vdd) is removed but the residual voltage remains. The residual voltage may trip below Vdd minimum, but not to zero. This condition may cause a poor power-on reset. Fig. 6-21 and Fig. 6-22 show how to create a protection circuit against residual voltage.

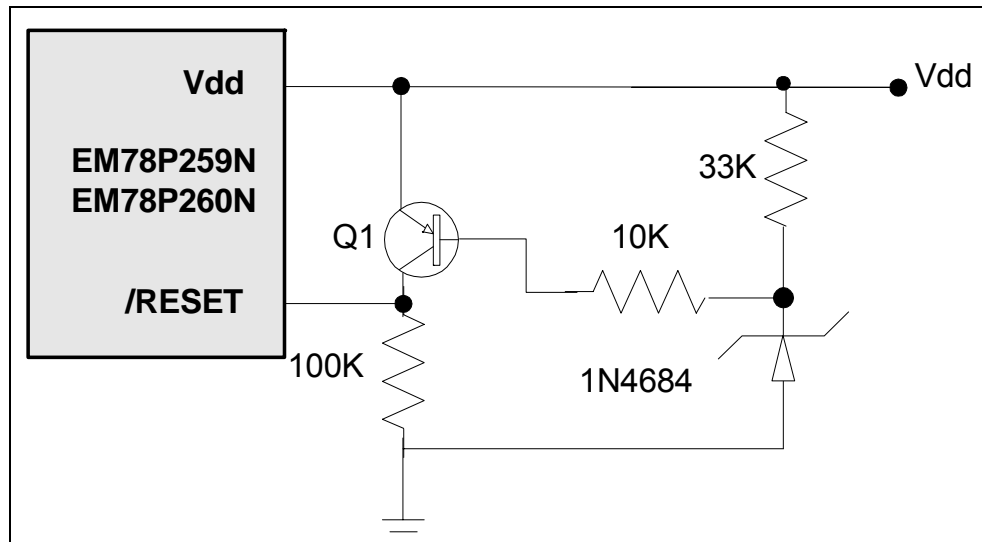

Fig 6-21 Residual Voltage Protection Circuit 1

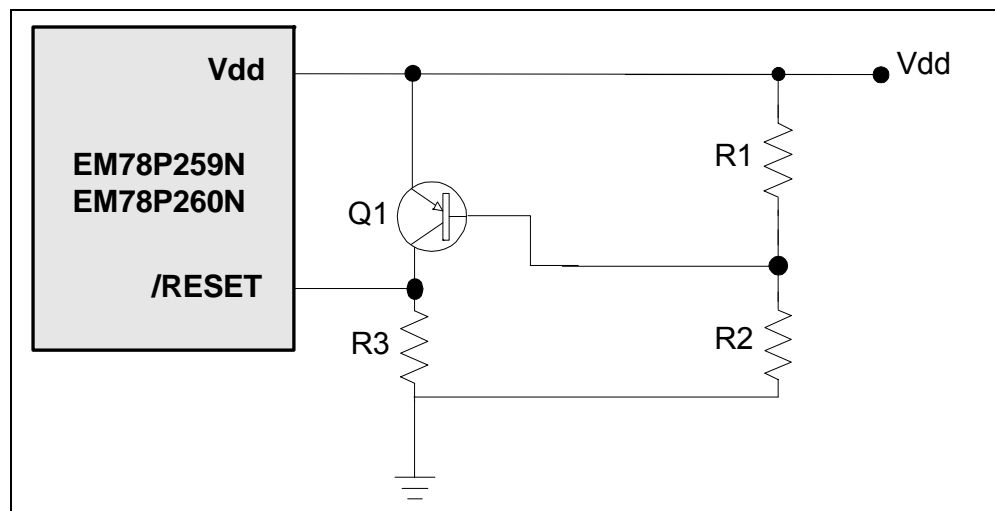

Fig 6-22 Residual Voltage Protection Circuit 2



6.13 Code Option

EM78P259N/260N has two Code option words and one Customer ID word that are not part of the normal program memory.

Word 0	Word1	Word 2
Bit 12 ~ Bit 0	Bit 12 ~ Bit 0	Bit 12 ~ Bit 0

6.13.1 Code Option Register (Word 0)

Word 0												
Bit 12	Bit 11	Bit 10	Bit 9	Bit 8	Bit 7	Bit 6	Bit 5	Bit 4	Bit 3	Bit 2	Bit 1	Bit 0
-	-	-	TYPE	CLKS	ENWDTB	OSC2	OSC1	OSC0	HLP	PR2	PR1	PR0

Bit 12 ~ 10: Not used (reserved). These bits are set to "1" all the time

Bit 9 (TYPE): Type selection for EM78P259N or EM78P260N
0 = EM78P260N
1 = EM78P259N (default)

Bit 8 (CLKS): Instruction period option bit
0 = two oscillator periods
1 = four oscillator periods (default)
 Refer to Section 6.15 for Instruction Set

Bit 7 (ENWDTB): Watchdog timer enable bit
0 = Enable
1 = Disable (default)

Bit 6, 5 & 4 (OSC2, OSC1 & OSC0): Oscillator Modes Selection bits

Oscillator Modes	OSC2	OSC1	OSC0
ERC ¹ (External RC oscillator mode); P70/OSCO acts as P70	0	0	0
ERC ¹ (External RC oscillator mode); P70/OSCO acts as OSC0	0	0	1
IRC ² (Internal RC oscillator mode); P70/OSCO acts as P70	0	1	0
IRC ² (Internal RC oscillator mode); P70/OSCO acts as OSC0	0	1	1
LXT ³ (Low XTAL oscillator mode)	1	1	0
HXT ³ High XTAL oscillator mode) (default)	1	1	1

Note: ¹ Under ERC mode, OSCI is used as oscillator pin. OSC0/P70 is defined by code option WORD0 Bit 6 ~ Bit 4.

² Under IRC mode, P55 is normal I/O pin. OSC0/P70 is defined by code option WORD0 Bit 6 ~ Bit 4.

³ Under LXT and HXT modes; OSCI and OSC0 are used as oscillator pins. These pins cannot and should not be defined as normal I/O pins.

NOTE

The transient point of the system frequency between HXT and LXY is around 400kHz.



Bit 3 (HLP): Power consumption selection

0 = Low power consumption, applies to working frequency at or below 4MHz

1 = High power consumption, applies to working frequency above 4MHz

Bit 2 ~ 0 (PR2 ~ PR0): Protect Bits

PR2 ~ PR0 are protect bits. Each protect status is as follows:

PR2	PR1	PR0	Protect
0	0	0	Enable
0	0	1	Enable
0	1	0	Enable
0	1	1	Enable
1	0	0	Enable
1	0	1	Enable
1	1	0	Enable
1	1	1	Disable

6.13.2 Code Option Register (Word 1)

Word 1												
Bit 12	Bit 11	Bit 10	Bit 9	Bit 8	Bit 7	Bit 6	Bit 5	Bit 4	Bit 3	Bit 2	Bit 1	Bit 0
-	-	RCOUT	NRHL	NRE	WDTPS	CYES	C3	C2	C1	C0	RCM1	RCM0

Bits 12 ~ 11: Not used (reserved). These bits are set to “1” all the time

Bit 10 (RCOUT): System clock output enable bit in IRC or ERC mode

0 = OSCO pin is open drain

1 = OSCO output system clock

Bit 9 (NRHL): Noise rejection high/low pulses define bit. INT pin is falling or rising edge trigger

0 = Pulses equal to $8/f_c$ [s] is regarded as signal

1 = Pulses equal to $32/f_c$ [s] is regarded as signal (default)

NOTE

The noise rejection function is turned off in LXT and sleep mode.

Bit 8 (NRE): Noise rejection enable

0 = disable noise rejection

1 = enable noise rejection (default), but under Low Crystal oscillator (LXT) mode, the noise rejection circuit is always disabled.



Bit 7 (WDTPS): WDT Time-out Period Selection bit

WDT Time	Watchdog Time*
1	18 ms
0	4.5 ms

* Theoretical values, for reference only

Bit 6 (CYES): Instruction cycle selection bit

0 = one instruction cycle

1 = two instructions cycle (default)

Bit 5, 4, 3, & Bit 2 (C3, C2, C1, C0): Calibration bits in internal RC mode

C3, C2, C1, & C0 must be set to "1" only (auto-calibration).

Bit 1 & Bit 0 (RCM1, RCM0): RC mode selection bits

RCM 1	RCM 0	Frequency (MHz)
1	1	4
1	0	8
0	1	1
0	0	455kHz

6.13.3 Customer ID Register (Word 2)

Word 2												
Bit 12	Bit 11	Bit 10	Bit 9	Bit 8	Bit 7	Bit 6	Bit 5	Bit 4	Bit 3	Bit 2	Bit 1	Bit 0
X	X	X	X	X	X	X	X	X	X	X	X	X

Bit 12 ~ 0: Customer's ID code

6.14 Instruction Set

Each instruction in the instruction set is a 13-bit word divided into an OP code and one or more operands. Normally, all instructions are executed within one single instruction cycle (one instruction consists of 2 oscillator periods), unless the program counter is changed by instructions "MOV R2,A," "ADD R2,A," or by instructions of arithmetic or logic operation on R2 (e.g., "SUB R2,A," "BS(C) R2,6," "CLR R2," etc.). In this case, these instructions need one or two instruction cycles as determined by Code Option Register CYES bit.

In addition, the instruction set has the following features:

1. Every bit of any register can be set, cleared, or tested directly.
2. The I/O registers can be regarded as general registers. That is, the same instruction can operate on I/O registers.



The symbol "R" represents a register designator that specifies which of the registers (including operational registers and general-purpose registers) is to be utilized by the instruction. The symbol "b" represents a bit field designator that selects the value for the bit located in the register "R" that is affected by the operation. The symbol "k" represents an 8 or 10-bit constant or literal value.

The following are the EM78P259N/260N instruction set

Convention:

R = Register designator that specifies which one of the registers (including operation and general purpose registers) is to be utilized by the instruction.

Bits 6 and 7 in R4 determine the selected register bank.

b = Bit field designator that selects the value for the bit located in the register R and which affects the operation.

k = 8 or 10-bit constant or literal value

Binary Instruction	Hex	Mnemonic	Operation	Status Affected
0 0000 0000 0000	0000	NOP	No Operation	None
0 0000 0000 0001	0001	DAA	Decimal Adjust A	C
0 0000 0000 0010	0002	CONTW	A → CONT	None
0 0000 0000 0011	0003	SLEP	0 → WDT, Stop oscillator	T, P
0 0000 0000 0100	0004	WDTC	0 → WDT	T, P
0 0000 0000 rrrr	000r	IOW R	A → IOCR	None ¹
0 0000 0001 0000	0010	ENI	Enable Interrupt	None
0 0000 0001 0001	0011	DISI	Disable Interrupt	None
0 0000 0001 0010	0012	RET	[Top of Stack] → PC	None
0 0000 0001 0011	0013	RETI	[Top of Stack] → PC, Enable Interrupt	None
0 0000 0001 0100	0014	CONTR	CONT → A	None
0 0000 0001 rrrr	001r	IOR R	IOCR → A	None ¹
0 0000 01rr rrrr	00rr	MOV R,A	A → R	None
0 0000 1000 0000	0080	CLRA	0 → A	Z
0 0000 11rr rrrr	00rr	CLR R	0 → R	Z
0 0001 00rr rrrr	01rr	SUB A,R	R-A → A	Z, C, DC
0 0001 01rr rrrr	01rr	SUB R,A	R-A → R	Z, C, DC
0 0001 10rr rrrr	01rr	DECA R	R-1 → A	Z
0 0001 11rr rrrr	01rr	DEC R	R-1 → R	Z
0 0010 00rr rrrr	02rr	OR A,R	A ∨ VR → A	Z
0 0010 01rr rrrr	02rr	OR R,A	A ∨ VR → R	Z
0 0010 10rr rrrr	02rr	AND A,R	A & R → A	Z
0 0010 11rr rrrr	02rr	AND R,A	A & R → R	Z
0 0011 00rr rrrr	03rr	XOR A,R	A ⊕ R → A	Z
0 0011 01rr rrrr	03rr	XOR R,A	A ⊕ R → R	Z
0 0011 10rr rrrr	03rr	ADD A,R	A + R → A	Z, C, DC
0 0011 11rr rrrr	03rr	ADD R,A	A + R → R	Z, C, DC
0 0100 00rr rrrr	04rr	MOV A,R	R → A	Z
0 0100 01rr rrrr	04rr	MOV R,R	R → R	Z
0 0100 10rr rrrr	04rr	COMA R	/R → A	Z
0 0100 11rr rrrr	04rr	COM R	/R → R	Z
0 0101 00rr rrrr	05rr	INCA R	R+1 → A	Z



Binary Instruction	Hex	Mnemonic	Operation	Status Affected
0 0101 01rr rrrr	05rr	INC R	R+1 → R	Z
0 0101 10rr rrrr	05rr	DJZA R	R-1 → A, skip if zero	None
0 0101 11rr rrrr	05rr	DJZ R	R-1 → R, skip if zero	None
0 0110 00rr rrrr	06rr	RRC A R	R(n) → A(n-1), R(0) → C, C → A(7)	C
0 0110 01rr rrrr	06rr	RRC R	R(n) → R(n-1), R(0) → C, C → R(7)	C
0 0110 10rr rrrr	06rr	RLCA R	R(n) → A(n+1), R(7) → C, C → A(0)	C
0 0110 11rr rrrr	06rr	RLC R	R(n) → R(n+1), R(7) → C, C → R(0)	C
0 0111 00rr rrrr	07rr	SWAPA R	R(0-3) → A(4-7), R(4-7) → A(0-3)	None
0 0111 01rr rrrr	07rr	SWAP R	R(0-3) ↔ R(4-7)	None
0 0111 10rr rrrr	07rr	JZA R	R+1 → A, skip if zero	None
0 0111 11rr rrrr	07rr	JZ R	R+1 → R, skip if zero	None
0 100b bbrr rrrr	0xxx	BC R,b	0 → R(b)	None ²
0 101b bbrr rrrr	0xxx	BS R,b	1 → R(b)	None ³
0 110b bbrr rrrr	0xxx	JBC R,b	if R(b)=0, skip	None
0 111b bbrr rrrr	0xxx	JBS R,b	if R(b)=1, skip	None
1 00kk kkkk kkkk	1kkk	CALL k	PC+1 → [SP], (Page, k) → PC	None
1 01kk kkkk kkkk	1kkk	JMP k	(Page, k) → PC	None
1 1000 kkkk kkkk	18kk	MOV A,k	k → A	None
1 1001 kkkk kkkk	19kk	OR A,k	A ∨ k → A	Z
1 1010 kkkk kkkk	1Akk	AND A,k	A & k → A	Z
1 1011 kkkk kkkk	1Bkk	XOR A,k	A ⊕ k → A	Z
1 1100 kkkk kkkk	1Ckk	RETL k	k → A, [Top of Stack] → PC	None
1 1101 kkkk kkkk	1Dkk	SUB A,k	k-A → A	Z, C, DC
1 1111 kkkk kkkk	1Fkk	ADD A,k	k+A → A	Z, C, DC

Note: ¹ This instruction is applicable to IOC50 ~ IOC60, IOC51 ~ IOC61 only.

² This instruction is not recommended for RF operation.

³ This instruction cannot operate under RF.

7 Absolute Maximum Ratings

Items	Rating		
Temperature under bias	-40°C	to	85°C
Storage temperature	-65°C	to	150°C
Input voltage	Vss-0.3V	to	Vdd+0.5V
Output voltage	Vss-0.3V	to	Vdd+0.5V
Working Voltage	2.5V	to	5.5V
Working Frequency	DC	to	20MHz

8 DC Electrical Characteristics

Ta=25 °C, VDD=5.0V±5%, VSS=0V

Symbol	Parameter	Condition	Min	Typ	Max	Unit
Fxt	Crystal: VDD to 5V	Two cycle with two clocks	DC	-	20	MHz
	Crystal: VDD to 3V		DC	-	8	MHz
	ERC: VDD to 5V	R: 5.1KΩ, C: 100 pF	F±30%	830	F±30%	kHz
	IRC: VDD to 5V	8MHz, 4MHz, 1MHz, 455kHz	F±30%	F	F±30%	Hz
IRC1	IRC:VDD to 5V	RCM0:RCM1=1:1	3.84	4.0	4.16	MHz
IRC2	IRC:VDD to 5V	RCM0:RCM1=1:0	7.68	8.0	8.32	MHz
IRC3	IRC:VDD to 5V	RCM0:RCM1=0:1	0.96	1.0	1.06	MHz
IRC4	IRC:VDD to 5V	RCM0:RCM1=0:0	436.8	455	473.2	kHz
VIHRC	Input High Threshold Voltage (Schmitt Trigger)	OSCI in RC mode	-	3.5	-	V
VILRC	Input Low Threshold Voltage (Schmitt Trigger)	OSCI in RC mode	-	1.5	-	V
IIL	Input Leakage Current for input pins	VIN = VDD, VSS	-1	0	1	μA
VIH1	Input High Voltage (Schmitt Trigger)	Ports 5, 6, 7	-	3.75	-	V
VIL1	Input Low Voltage (Schmitt Trigger)	Ports 5, 6, 7	-	1.25	-	V
VIHT1	Input High Threshold Voltage (Schmitt Trigger)	/RESET	-	2.0	-	V
VILT1	Input Low Threshold Voltage (Schmitt Trigger)	/RESET	-	1.0	-	V
VIHT2	Input High Threshold Voltage (Schmitt Trigger)	TCC,INT	-	3.75	-	V
VILT2	Input Low Threshold Voltage (Schmitt Trigger)	TCC,INT	-	1.25	-	V
VIHX1	Clock Input High Voltage	OSCI in crystal mode	-	3.5	-	V
VILX1	Clock Input Low Voltage	OSCI in crystal mode	-	1.5	-	V
IOH1	Output High Voltage (Ports 5, P60~66, P70)	VOH = VDD-0.5V	-	-3.7	-	mA
IOH2	Output High Voltage (IR OUT (Port 67))	VOH = VDD-0.5V	-	-10	-	mA
IOL1	Output Low Voltage (Ports 5, P60~66, P70)	VOL = GND+0.5V	-	10	-	mA
IOL2	Output Low Voltage (IR OUT (Port 67))	VOL = GND+0.5V	-	15	-	mA
IPH	Pull-high current	Pull-high active, input pin at VSS	-70	-75	-80	μA
IPL	Pull-low current	Pull-low active, input pin at Vdd	35	40	45	μA
ISB1	Power down current	All input and I/O pins at VDD, output pin floating, WDT disabled	-	1.0	2.0	μA
ISB2	Power down current	All input and I/O pins at VDD, output pin floating, WDT enabled	-	6.0	10	μA



Symbol	Parameter	Condition	Min	Typ	Max	Unit
ICC1	Operating supply current at two clocks (VDD to 3V)	/RESET= 'High', Fosc=32kHz (Crystal type,CLKS="0"), output pin floating, WDT disabled	-	15	20	μA
ICC2	Operating supply current at two clocks (VDD to 3V)	/RESET= 'High', Fosc=32kHz (Crystal type,CLKS="0"), output pin floating, WDT enabled	-	15	25	μA
ICC3	Operating supply current at two clocks	/RESET= 'High', Fosc=4MHz (Crystal type, CLKS="0"), output pin floating, WDT enabled	-	1.9	2.2	mA
ICC4	Operating supply current at two clocks	/RESET= 'High', Fosc=10MHz (Crystal type, CLKS="0"), output pin floating, WDT enabled	-	3.0	3.5	mA

- Note:**
1. These parameters are hypothetical (not tested) and are provided for design reference use only.
 2. Data under minimum, typical, & maximum (Min, Typ, & Max) columns are based on hypothetical results at 25°C. These data are for design reference only.

8.1 AD Converter Characteristics

Vdd=2.5V to 5.5V, Vss=0V, Ta=25°C

Symbol	Parameter	Condition	Min.	Typ.	Max.	Unit	
V _{AREF}	Analog reference voltage	V _{AREF} - V _{ASS} ≥ 2.5V	2.5	-	V _{dd}	V	
V _{ASS}			V _{ss}	-	V _{ss}	V	
V _{AI}	Analog input voltage	-	V _{ASS}	-	V _{AREF}	V	
IAI1	Analog supply current	V _{dd} =V _{AREF} =5.0V, V _{ASS} =0.0V (V referenced from V _{dd})	I _{vdd}	750	850	1000	μA
			I _{vref}	-10	0	+10	μA
IAI2	Analog supply current	V _{dd} =V _{AREF} =5.0V, V _{ASS} =0.0V (V referenced from V _{REF})	I _{vdd}	500	600	820	μA
			I _{vref}	200	250	300	μA
IOP	OP current	V _{dd} =5.0V, OP used Output voltage swing 0.2V to 4.8V	450	550	650	μA	
RN	Resolution	V _{dd} =V _{AREF} =5.0V, V _{ASS} =0.0V	10	11	-	Bits	
LN	Linearity error	V _{dd} = 2.5 to 5.5V Ta=25°C	0	±4	±8	LSB	
DNL	Differential nonlinear error	V _{dd} = 2.5 to 5.5V Ta=25°C	0	±0.5	±0.9	LSB	
FSE	Full scale error	V _{dd} =V _{AREF} =5.0V, V _{ASS} =0.0V	±0	±4	±8	LSB	
OE	Offset error	V _{dd} =V _{AREF} =5.0V, V _{ASS} =0.0V	±0	±2	±4	LSB	
ZAI	Recommended impedance of analog voltage source	-	0	8	10	KΩ	
TAD	ADC clock period	V _{dd} =V _{AREF} =5.0V, V _{ASS} =0.0V	4	-	-	us	
TCN	AD conversion time	V _{dd} =V _{AREF} =5.0V, V _{ASS} =0.0V	15	-	15	TAD	
ADIV	ADC OP input voltage range	V _{dd} =V _{AREF} =5.0V, V _{ASS} =0.0V	0	-	V _{AREF}	V	
ADOV	ADC OP output voltage swing	V _{dd} =V _{AREF} =5.0V, V _{ASS} =0.0V, RL=10KΩ	0	0.2	0.3	V	
			4.7	4.8	5		
ADSR	ADC OP slew rate	V _{dd} =V _{AREF} =5.0V, V _{ASS} =0.0V	0.1	0.3	-	V/us	
PSR	Power Supply Rejection	V _{dd} =5.0V±0.5V	±0	-	±2	LSB	

- Note:**
1. These parameters are hypothetical (not tested) and are provided for design reference use only.
 2. There is no current consumption when ADC is off other than minor leakage current.
 3. AD conversion result will not decrease when an increase of input voltage and no missing code will result.



8.2 Comparator (OP) Characteristics

Vdd = 5.0V, Vss=0V, Ta=25°C)

Symbol	Parameter	Condition	Min.	Typ.	Max.	Unit
SR	Slew rate	-	0.1	0.2	-	V/us
IVR	Input voltage range	Vdd =5.0V, Vss =0.0V	0	-	5	V
OVS	Output voltage swing	Vd =5.0V, Vss =0.0V, RL=10KΩ	0	0.2	0.3	V
			4.7	4.8	5	
Iop	Supply current of OP	-	250	350	500	uA
Ico	Supply current of Comparator	-	-	300	-	uA
PSR R	Power-supply Rejection Ration for OP	Vdd= 5.0V, Vss =0.0V	50	60	70	dB
Vs	Operating range	-	2.5		5.5	V

Note: These parameters are hypothetical (not tested) and are provided for design reference only.

8.3 Device Characteristics

The graphs below were derived based on a limited number of samples and they are provided for reference only. Hence, the device characteristic shown herein cannot be guaranteed as fully accurate. In these graphs, the data maybe out of the specified operating warranted range.

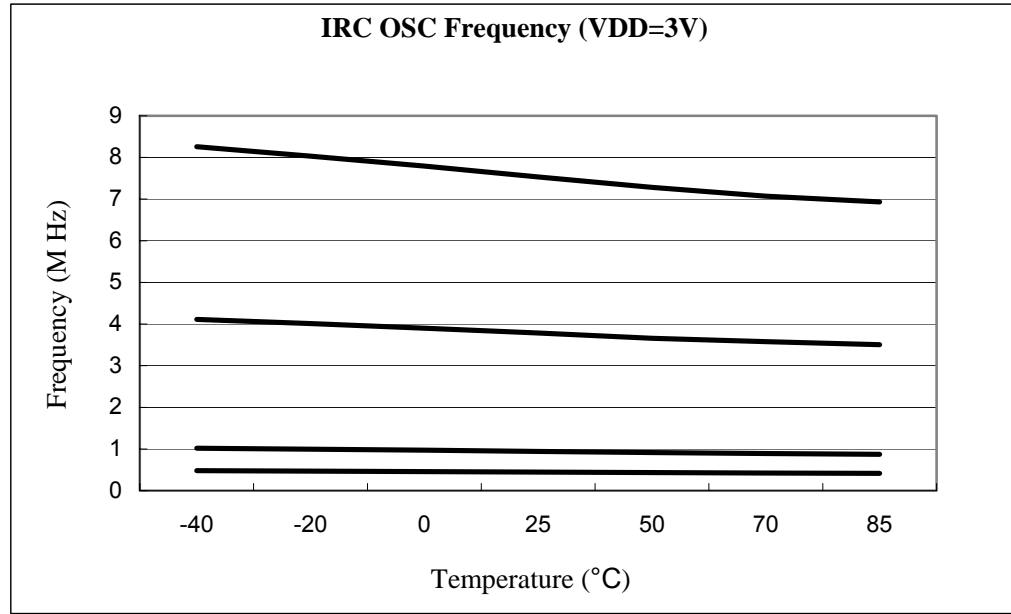

Fig 8-1 Internal RC OSC Frequency vs. Temperature, VDD=3V

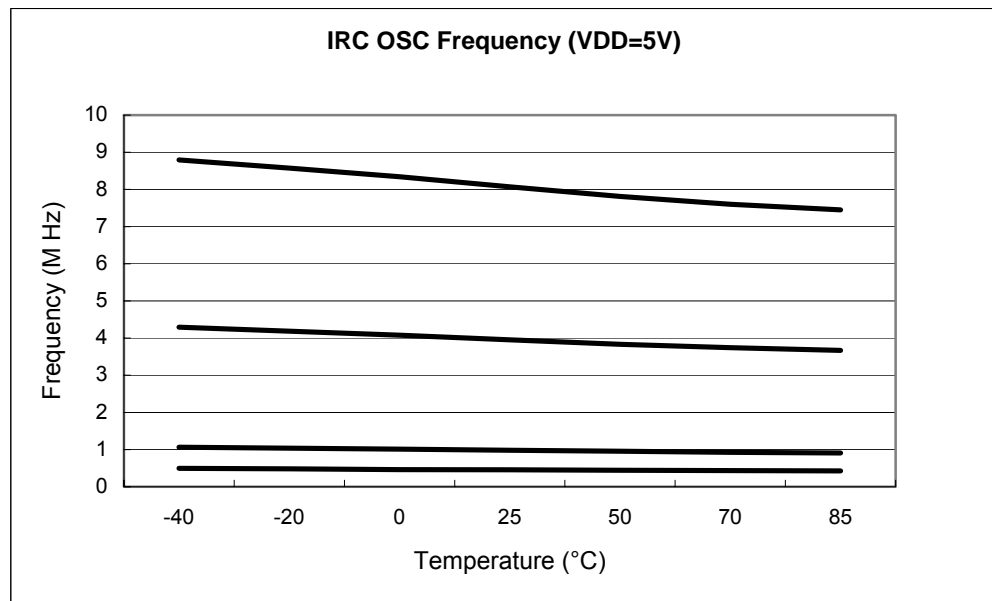

Fig 8-2 Internal RC OSC Frequency vs. Temperature, VDD=5V

9 AC Electrical Characteristic

Ta=25 °C, VDD=5V±5%, VSS=0V

Symbol	Parameter	Conditions	Min	Typ	Max	Unit
Dclk	Input CLK duty cycle	-	45	50	55	%
Tins	Instruction cycle time (CLKS="0")	Crystal type	100	-	DC	ns
		RC type	500	-	DC	ns
Ttcc	TCC input period	-	(Tins+20)/N*	-	-	ns
Tdrh	Device reset hold time	Ta = 25°C	11.3	16.2	21.6	ms
Trst	/RESET pulse width	Ta = 25°C	2000	-	-	ns
Twdt	Watchdog timer period	Ta = 25°C	11.3	16.2	21.6	ms
Tset	Input pin setup time	-	-	0	-	ns
Thold	Input pin hold time	-	15	20	25	ns
Tdelay	Output pin delay time	Cload=20pF	45	50	55	ns
Tdrc	ERC delay time	Ta = 25°C	1	3	5	ns

- Note:**
1. N = selected prescaler ratio
 2. Twdt1: The Option Word 1 (WDTPS) is used to define the oscillator set-up time. WDT timeout length is the same as set-up time (18ms).
 3. Twdt2: The Option Word 1 (WDTPS) is used to define the oscillator set-up time. WDT timeout length is the same as set-up time (4.5ms).
 4. These parameters are hypothetical (not tested) and are provided for design reference only.
 5. Data under minimum, typical, & maximum (Min, Typ, & Max) columns are based on hypothetical results at 25°C. These data are for design reference use only.
 6. The Watchdog timer duration is determined by code option Word1 (WDTPS).

10 Timing Diagrams

AC Test Input/Output Waveform

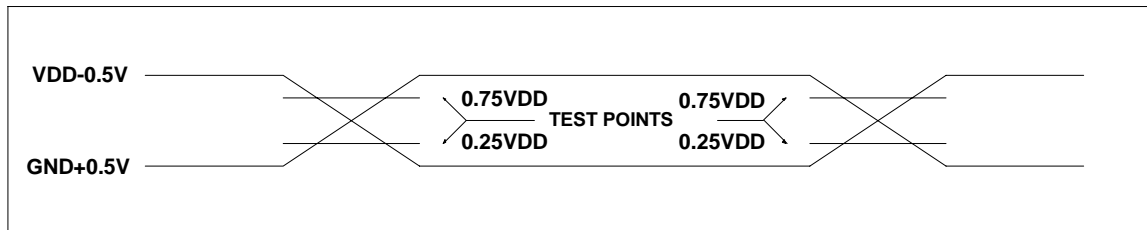

AC Testing : Input is driven at VDD-0.5V for logic "1", and GND+0.5V for logic "0". Timing measurements are made at 0.75VDD for logic "1", and 0.25VDD for logic "0".

RESET Timing (CLK="0")

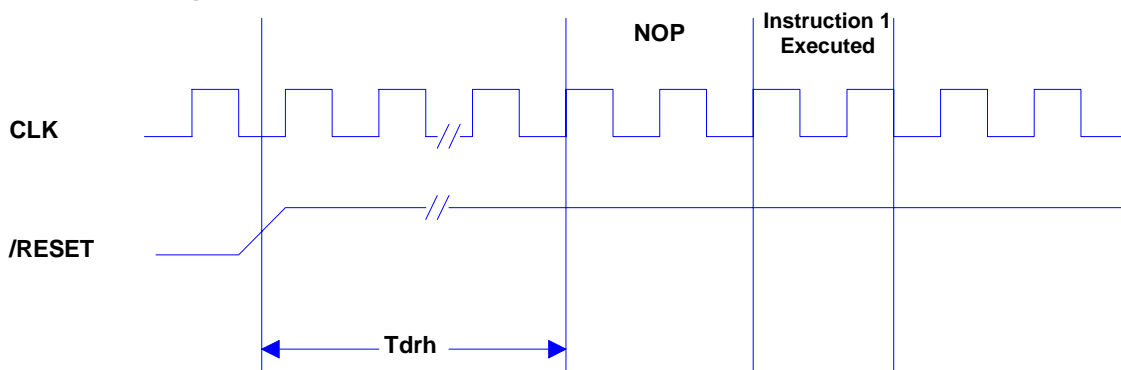

TCC Input Timing (CLKS="0")

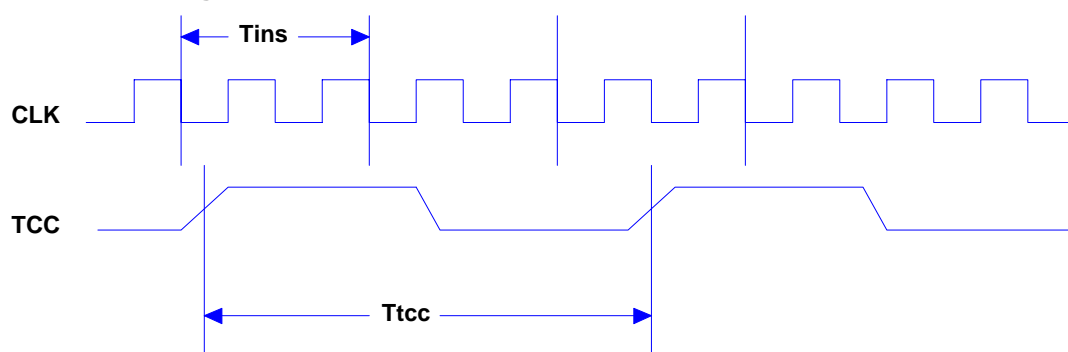

APPENDIX

A Package Type Summary

OTP MCU	Package Type	Pin Count	Package Size
EM78P259NP	DIP	18	300mil
EM78P259NM	SOP	18	300mil
EM78P260NP	DIP	20	300mil
EM78P260NM	SOP	20	300mil
EM78P260NKM	SSOP	20	209mil

B Packaging Configurations

B.1 18-Lead Plastic Dual in line (PDIP) — 300 mil

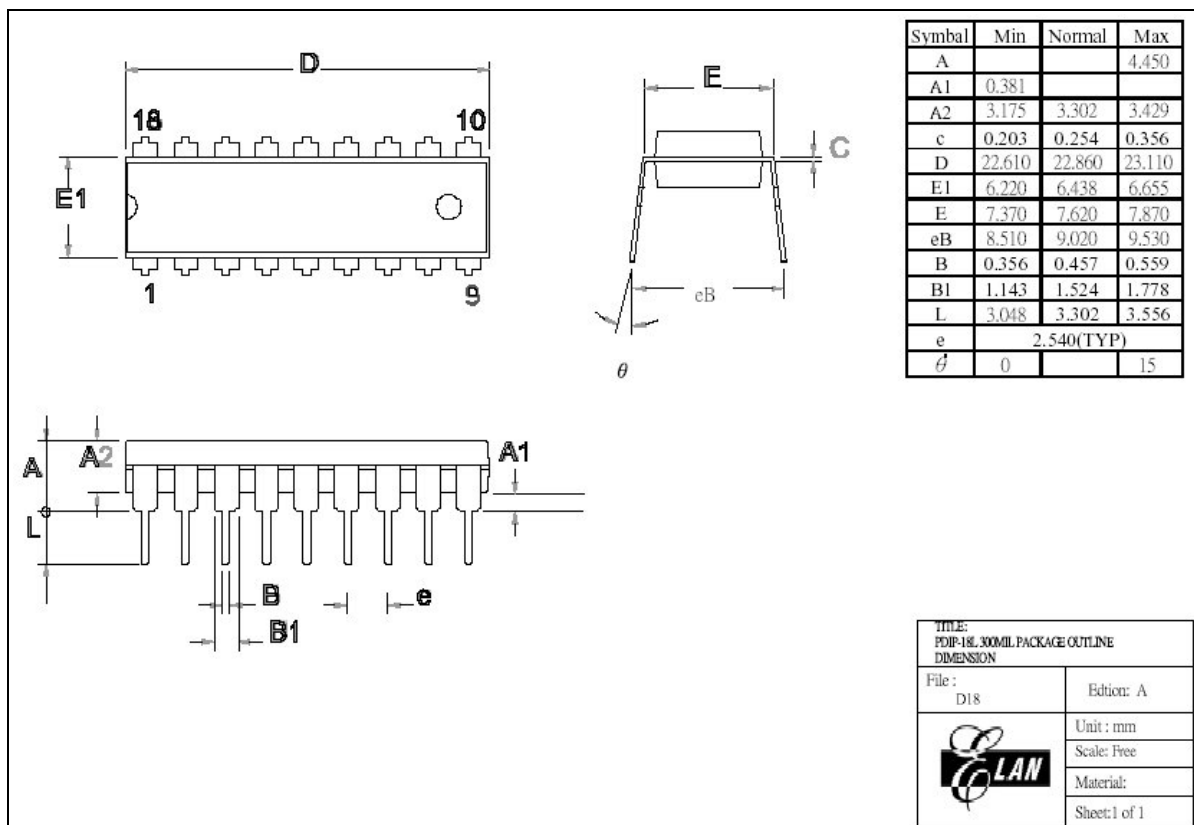

B.2 18-Lead Plastic Small Outline (SOP) — 300 mil

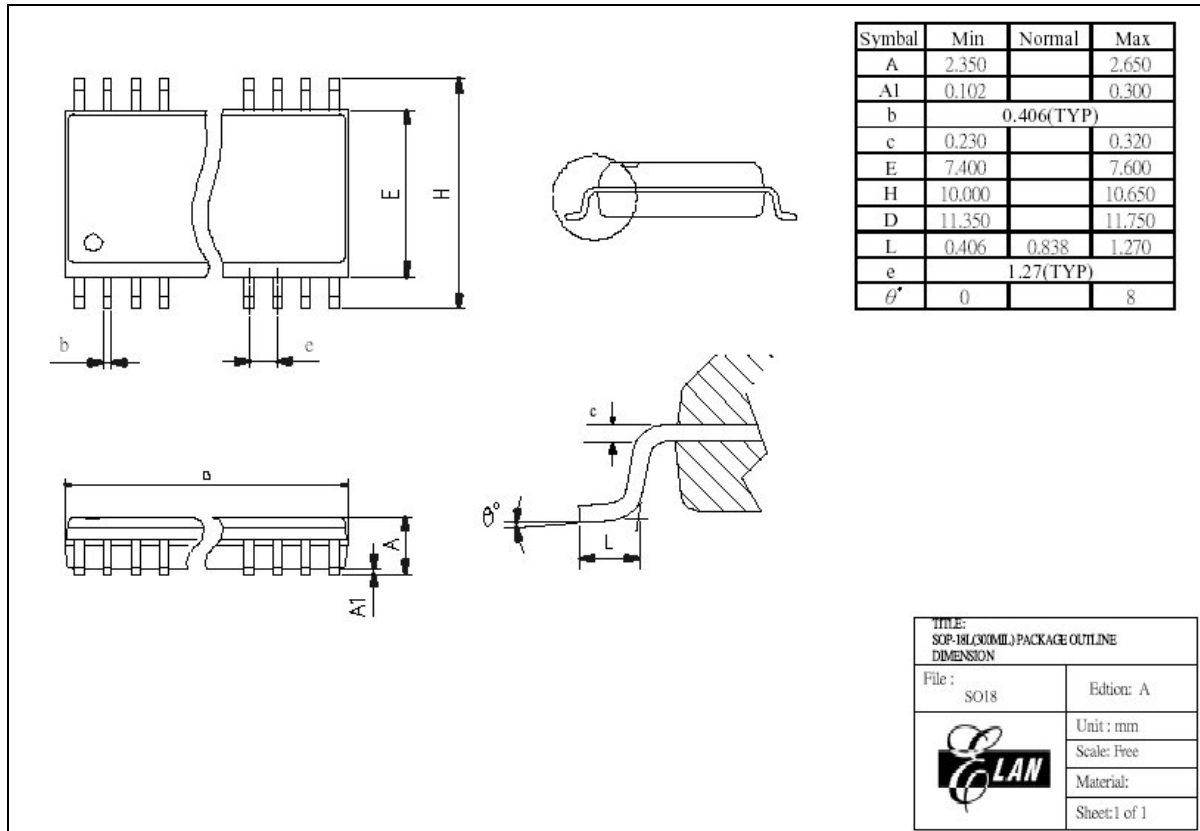



B.3 20-Lead Plastic Shrink Small Outline (SSOP) — 209 mil

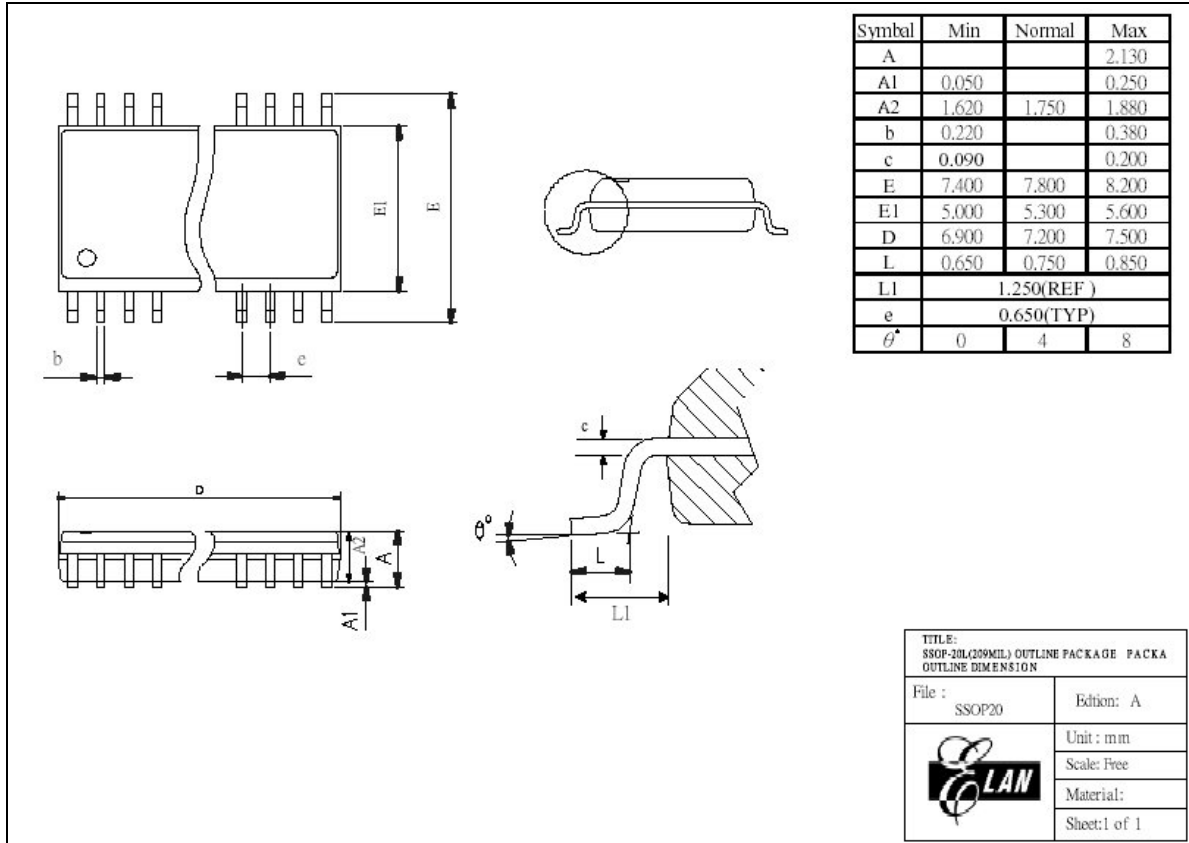

B.4 20-Lead Plastic Dual-in-line (PDIP) — 300 mil

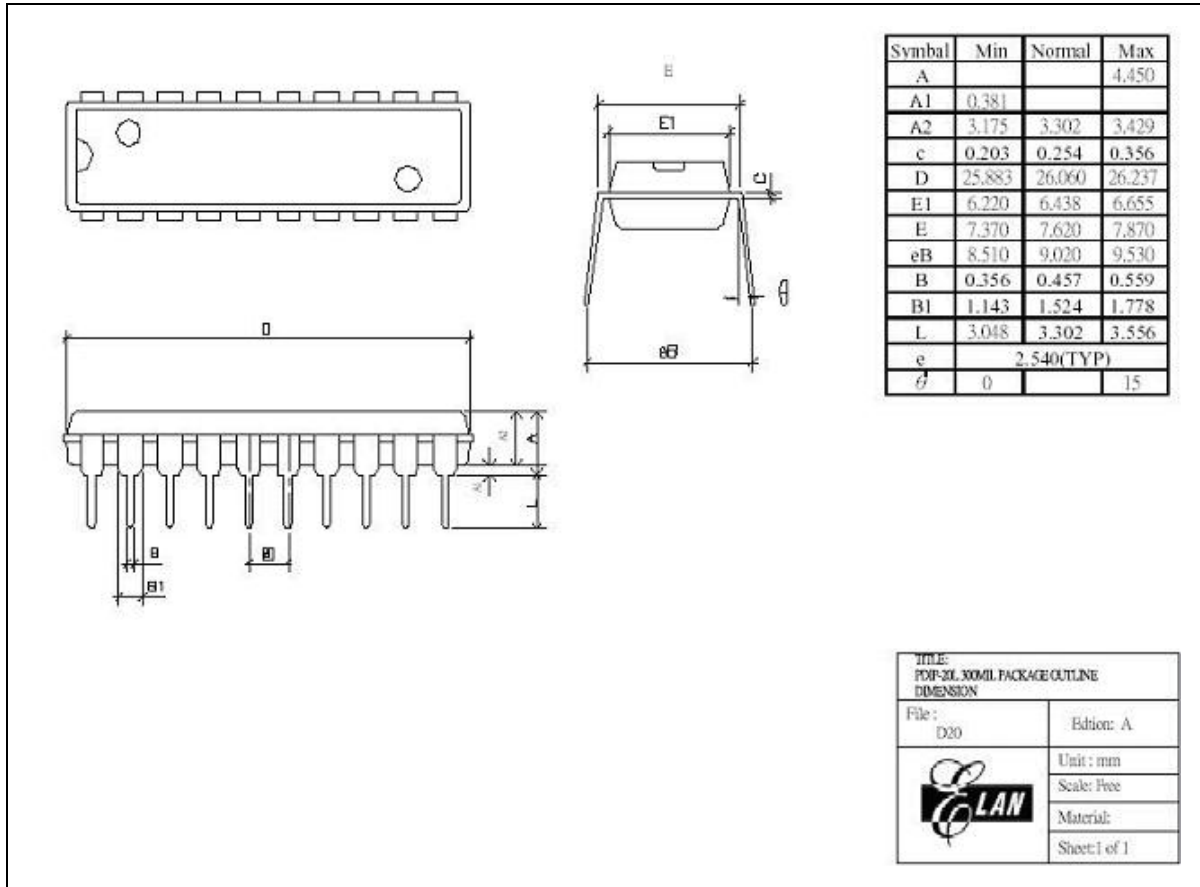



B.5 20-Lead Plastic Small Outline (SOPP) — 300 mil

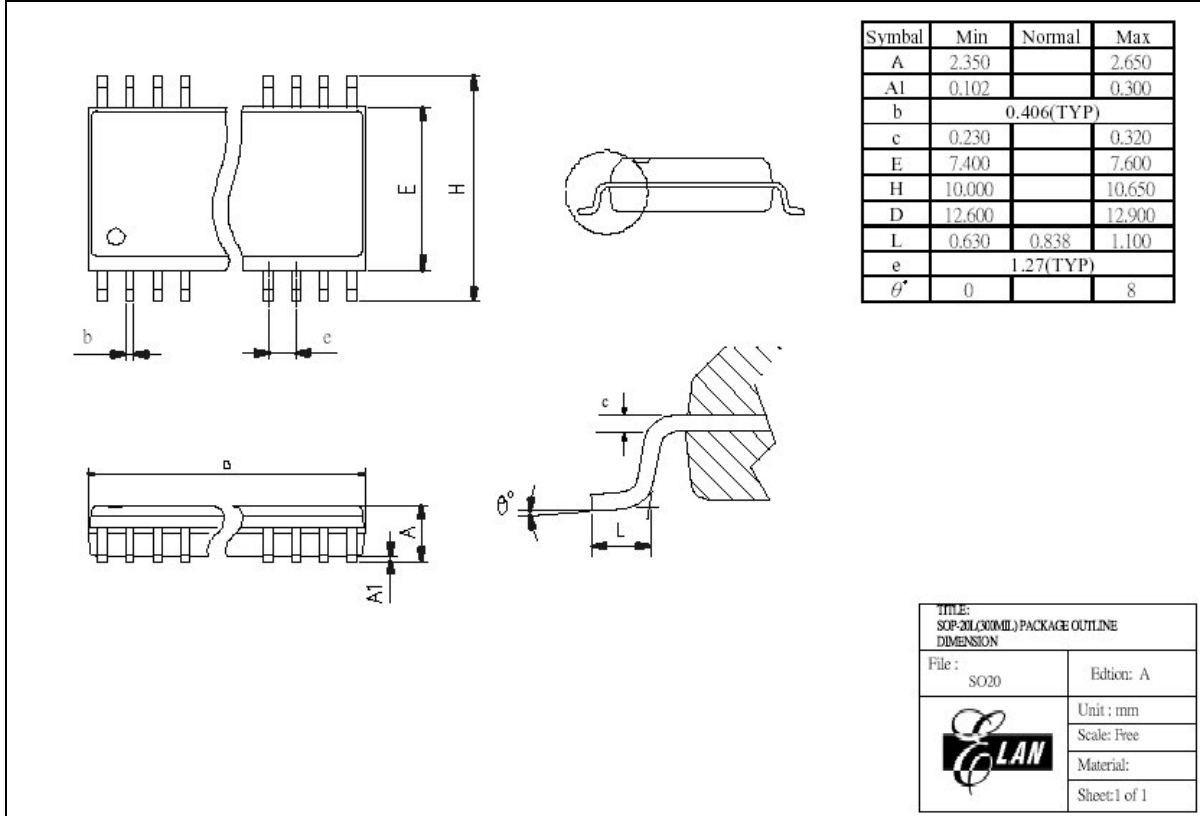

C Quality Assurance and Reliability

Test Category	Test Conditions	Remarks
Solderability	Solder temperature = 245±5°C, for 5 seconds up to the stopper using a rosin-type flux	
Pre-condition	Step 1: TCT, 65°C ~150°C, 10 cycles (15 mins)	For SMD IC (such as SOP, QFP, SOJ, etc)
	Step 2: Bake at 125°C, TD (durance) = 24 hrs	
	Step 3: Soak at 30°C/60% , TD (durance) = 192 hrs	
	Step 4: IR flow 3 cycles (Pkg thickness ≥ 2.5 mm or Pkg volume ≥ 350 mm ³ ----225 ± 5°C) (Pkg thickness ≤ 2.5 mm or Pkg volume ≤ 350 mm ³ ----240 ± 5°C)	
Temperature cycle test	-65°C ~150°C, 200 cycles (15 mins)	
Pressure cooker test	TA =121°C, RH=100%, pressure = 2 atm, TD (durance) = 96 hrs	
High temperature / High humidity test	TA=85°C , RH=85% , TD (durance) = 168, 500 hrs	
High-temperature storage life	TA=150°C, TD (durance) = 500, 1000 hrs	
High-temperature operating life	TA=125°C, VCC=Max. operating voltage, TD (durance) =168, 500, 1000 hrs	
Latch-up	TA=25°C, VCC = max. operating voltage, 150mA/20V	
ESD (HBM)	TA=25°C, ≥ ± 3KV	IP_ND,OP_ND,IO_ND IP_NS,OP_NS,IO_NS IP_PD,OP_PD,IO_PD, IP_PS,OP_PS,IO_PS, VDD-VSS(+),VDD_VSS (-) mode
ESD (MM)	TA=25°C, ≥ ± 300V	

C.1 Address Trap Detect

An address trap detect is one of the MCU embedded fail-safe functions that detects MCU malfunction caused by noise or the like. Whenever the MCU attempts to fetch an instruction from a certain section of ROM, an internal recovery circuit is auto started. If a noise caused address error is detected, the MCU will repeat execution of the program until the noise is eliminated. The MCU will then continue to execute the next program.

