

Standard Rectifier Module

$$V_{RRM} = 2 \times 1600 \text{ V}$$

$$I_{FAV} = 380 \text{ A}$$

$$V_F = 0.93 \text{ V}$$

Phase leg

Part number

MDMA380P1600KC

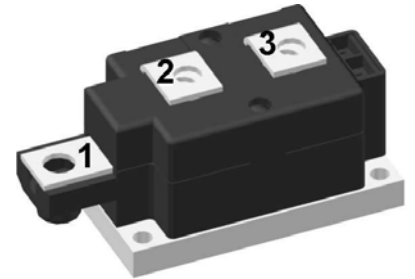

Backside: isolated

 E72873

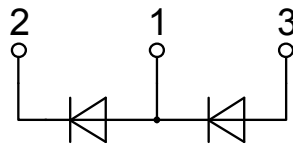

Features / Advantages:

- Planar passivated chips
- Very low leakage current
- Very low forward voltage drop
- Improved thermal behaviour

Applications:

- Diode for main rectification
- For single and three phase bridge configurations
- Supplies for DC power equipment
- Input rectifiers for PWM inverter
- Battery DC power supplies
- Field supply for DC motors

Package: Y1

- Isolation Voltage: 4800 V~
- Industry standard outline
- RoHS compliant
- Base plate: Copper internally DCB isolated
- Advanced power cycling

Rectifier				Ratings				
Symbol	Definition	Conditions		min.	typ.	max.	Unit	
V_{RSM}	max. non-repetitive reverse blocking voltage					1700	V	
V_{RRM}	max. repetitive reverse blocking voltage					1600	V	
I_R	reverse current	$V_R = 1600$ V	$T_{VJ} = 25^\circ\text{C}$			500	μA	
		$V_R = 1600$ V	$T_{VJ} = 150^\circ\text{C}$			20	mA	
V_F	forward voltage drop	$I_F = 300$ A	$T_{VJ} = 25^\circ\text{C}$			1.05	V	
						1.18	V	
		$I_F = 600$ A	$T_{VJ} = 125^\circ\text{C}$			0.93	V	
						1.10	V	
I_{FAV}	average forward current	$T_C = 100^\circ\text{C}$ rectangular $d = 0.5$	$T_{VJ} = 150^\circ\text{C}$			380	A	
V_{FO}	threshold voltage	} for power loss calculation only				0.75	V	
r_F	slope resistance					0.53	m Ω	
R_{thJC}	thermal resistance junction to case					0.11	K/W	
R_{thCH}	thermal resistance case to heatsink				0.04		K/W	
P_{tot}	total power dissipation			$T_C = 25^\circ\text{C}$		1140	W	
I_{FSM}	max. forward surge current	$t = 10$ ms; (50 Hz), sine	$T_{VJ} = 45^\circ\text{C}$			11.0	kA	
						11.9	kA	
		$t = 8,3$ ms; (60 Hz), sine	$V_R = 0$ V	$T_{VJ} = 150^\circ\text{C}$			9.35	kA
							10.1	kA
I^2t	value for fusing	$t = 10$ ms; (50 Hz), sine	$T_{VJ} = 45^\circ\text{C}$			605.0	kA ² s	
						587.1	kA ² s	
		$t = 8,3$ ms; (60 Hz), sine	$V_R = 0$ V	$T_{VJ} = 150^\circ\text{C}$			437.1	kA ² s
							424.4	kA ² s
C_J	junction capacitance	$V_R = 400$ V; $f = 1$ MHz		$T_{VJ} = 25^\circ\text{C}$		27	pF	

Package Y1			Ratings			
Symbol	Definition	Conditions	min.	typ.	max.	Unit
I_{RMS}	RMS current	per terminal			600	A
T_{VJ}	virtual junction temperature		-40		150	°C
T_{op}	operation temperature		-40		125	°C
T_{stg}	storage temperature		-40		125	°C
Weight				750		g
M_D	mounting torque		4.5		7	Nm
M_T	terminal torque		11		13	Nm
$d_{Spp/APP}$	creepage distance on surface striking distance through air	terminal to terminal	16.0			mm
$d_{Spb/Apb}$		terminal to backside	16.0			mm
V_{ISOL}	isolation voltage	t = 1 second	4800			V
		t = 1 minute	4000			V

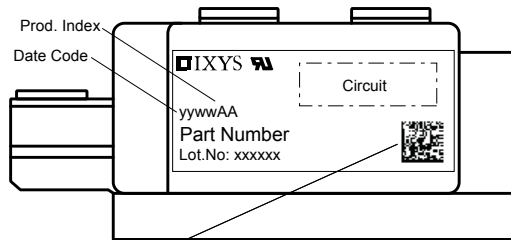

Data Matrix: Typ (1-19), DC+Prod.Index (20-25), FKT# (26-31)
leer (33), Ifid.# (33-36)

Part number

- M = Module
- D = Diode
- M = Standard Rectifier
- A = (up to 1800V)
- 380 = Current Rating [A]
- P = Phase leg
- 1600 = Reverse Voltage [V]
- KC = Y1-CU

Ordering	Part Number	Marking on Product	Delivery Mode	Quantity	Code No.
Standard	MDMA380P1600KC	MDMA380P1600KC	Box	3	512611

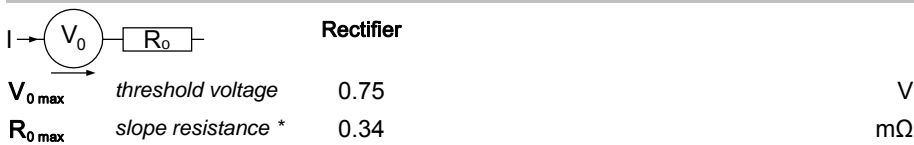
Equivalent Circuits for Simulation
** on die level*
 $T_{VJ} = 150\text{ °C}$

Outlines Y1

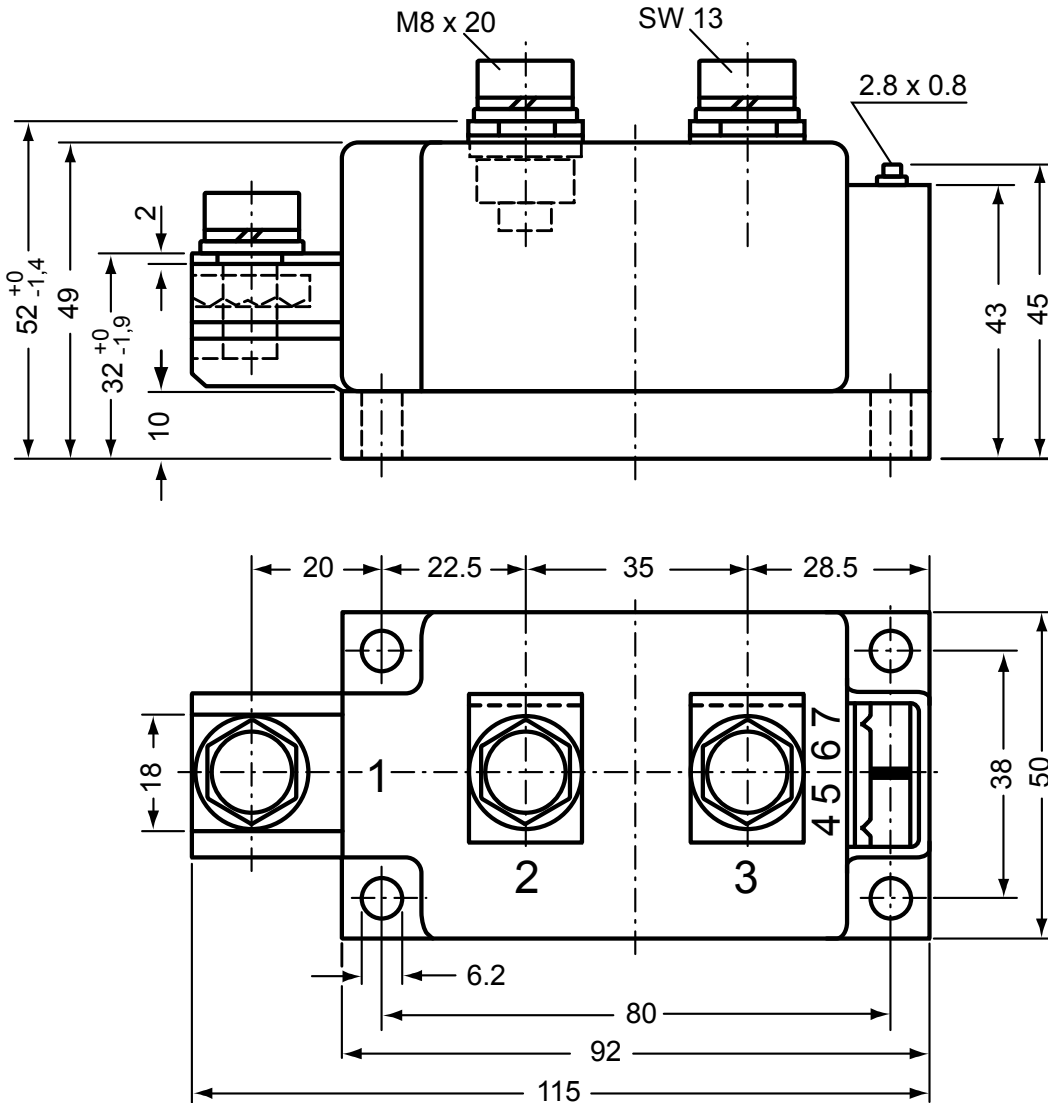

Optional accessories for modules

Keyed gate/cathode twin plugs with wire length = 350 mm, gate = white, cathode = red

Type ZY 180L (L = Left for pin pair 4/5)
 Type ZY 180R (R = Right for pin pair 6/7) } UL 758, style 3751

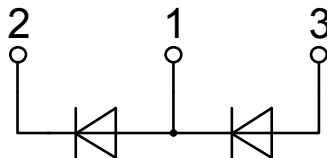

Rectifier

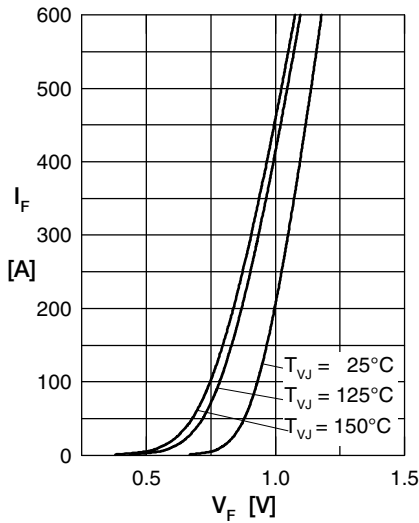

Fig. 1 Forward current versus voltage drop per diode

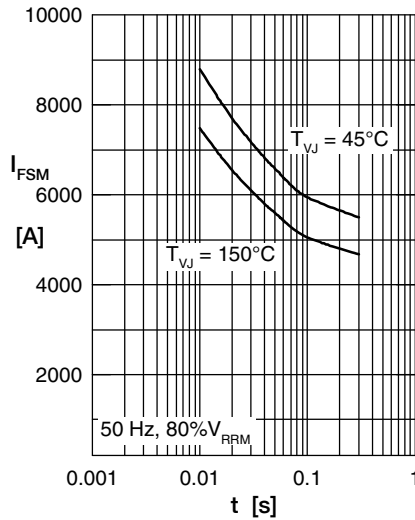

Fig. 2 Surge overload current vs. time per diode

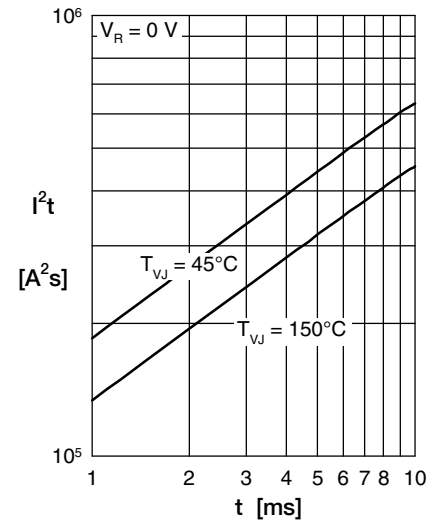

Fig. 3 I^2t versus time per diode

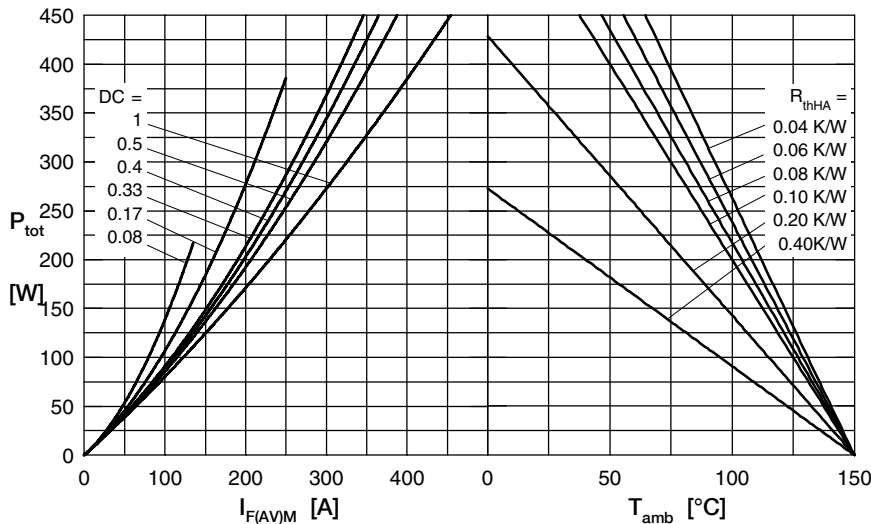

Fig. 4 Power dissipation vs. forward current and ambient temperature per diode

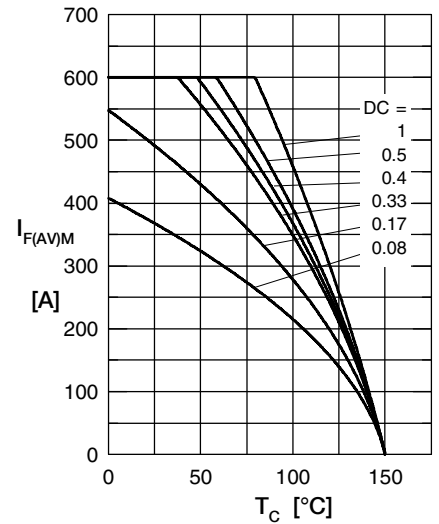

Fig. 5 Max. forward current vs. case temperature per diode

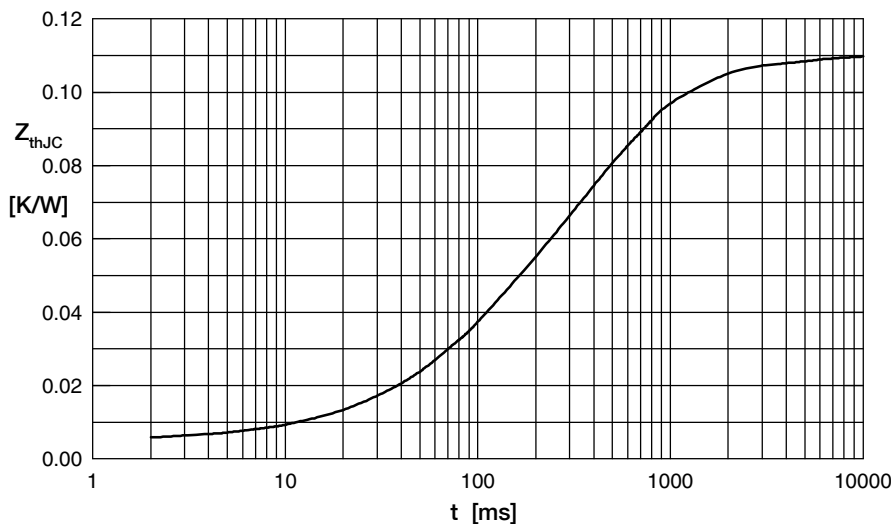

Fig. 6 Transient thermal impedance junction to case vs. time per diode

Constants for Z_{thJC} calculation:

i	R_{thi} (K/W)	t_i (s)
1	0.005	0.0005
2	0.029	0.0980
3	0.068	0.4500
4	0.008	3.0000