



# Winstar Display Co., LTD

## 華凌光電股份有限公司



住址: 407 台中市中清路 163 號  
No.163 Chung Ching RD.,  
Taichune, Taiwan, R.O.C

WEB: <http://www.winstar.com.tw>  
E-mail: sales@winstar.com.tw  
Tel:886-4-24262208 Fax : 886-4-24262207

### SPECIFICATION

**CUSTOMER :** \_\_\_\_\_

**MODULE NO.:** WH1602C-TMI-CT#

<b>APPROVED BY:</b>  ( FOR CUSTOMER USE ONLY )	<b>PCB VERSION:</b>	<b>DATA:</b>

SALES BY	APPROVED BY	CHECKED BY	PREPARED BY

VERSION	DATE	REVISED PAGE NO.	SUMMARY
C	2011/7/28	21	Modify backlight information.

RECORDS OF REVISION			DOC. FIRST ISSUE
VERSION	DATE	REVISED PAGE NO.	SUMMARY
0	2007.06.28		First issue
A	2008/5/12	20	Modify backlight information.
B	2009/4/30	20	Modify backlight information.
C	2011/7/28	21	Modify backlight information.

# **Contents**

- 1.Module Classification Information
- 2.Precautions in use of LCD Modules
- 3.General Specification
- 4.Absolute Maximum Ratings
- 5.Electrical Characteristics
- 6.Optical Characteristics
- 7.Interface Pin Function
- 8.Contour Drawing & Block Diagram
- 9.Function Description
- 10.Character Generator ROM Pattern
- 11.Instruction Table
- 12.Timing Characteristics
- 13.Initializing of LCM
- 14.Reliability
- 15.Backlight Information
16. Inspection specification
17. Material List of Components for RoHs
18. Recommendable storage

# 1.Module Classification Information

W H   1 6 0 2   C-T M I-   CT#  
 ① ②                    ③                    ④ ⑤ ⑥ ⑦                    ⑧

- ① Brand : WINSTAR DISPLAY CORPORATION
- ② Display Type : H→Character Type, G→Graphic Type
- ③ Display Font : Character 16 words, 2Lines.
- ④ Model serials no.
- ⑤ Backlight Type :     N→Without backlight                    T→LED, White  
                               B→EL, Blue green    A→LED, Amber  
                               D→EL, Green    R→LED, Red  
                               W→EL, White    O→LED, Orange  
                               F→CCFL, White    G→LED, Green  
                               Y→LED, Yellow Green
- ⑥ LCD Mode :            B→TN Positive, Gray                    T→FSTN Negative  
                               N→TN Negative,  
                               G→STN Positive, Gray  
                               Y→STN Positive, Yellow Green  
                               M→STN Negative, Blue  
                               F→FSTN Positive
- ⑦ LCD Polarize Type/    A→Reflective, N.T, 6:00                    H→Transflective, W.T,6:00  
   Temperature range/    D→Reflective, N.T, 12:00                    K→Transflective, W.T,12:00  
   View direction        G→Reflective, W. T, 6:00                    C→Transmissive, N.T,6:00  
                                   J→Reflective, W. T, 12:00                    F→Transmissive, N.T,12:00  
                                   B→Transflective, N.T,6:00                    I→Transmissive, W. T, 6:00  
                                   E→Transflective, N.T,12:00                    L→Transmissive, W.T,12:00
- ⑧ Special Code            CT: English and Cyrillic standard font;  
                                   #:Fit in with the ROHS Directions and regulations

## **2.Precautions in use of LCD Modules**

- (1) Avoid applying excessive shocks to the module or making any alterations or modifications to it.
- (2) Don't make extra holes on the printed circuit board, modify its shape or change the components of LCD module.
- (3) Don't disassemble the LCM.
- (4) Don't operate it above the absolute maximum rating.
- (5) Don't drop, bend or twist LCM.
- (6) Soldering: only to the I/O terminals.
- (7) Storage: please storage in anti-static electricity container and clean environment.
- (8) Winstar have the right to change the passive components, including R3,R6 & backlight adjust resistors. (Resistors, capacitors and other passive components will have different appearance and color caused by the different supplier.)
- (9) Winstar have the right to change the PCB Rev. (In order to satisfy the supplying stability, management optimization and the best product performance...etc, under the premise of not affecting the electrical characteristics and external dimensions, Winstar have the right to modify the version.)

## **3.General Specification**

<b>Item</b>	<b>Dimension</b>	<b>Unit</b>
Number of Characters	16 characters x 2 Lines	—
Module dimension	85.0 x 36.0 x 13.5(MAX)	mm
View area	66.0 x 16.0	mm
Active area	56.2 x 11.5	mm
Dot size	0.55 x 0.65	mm
Dot pitch	0.60 x 0.70	mm
Character size	2.95 x 5.55	Nmm
Character pitch	3.55 x 5.95	mm
LCD type	STN, Negative , Transmissive , Blue (In LCD production, It will occur slightly color difference. We can only guarantee the same color in the same batch.)	
Duty	1/16	
View direction	6 o'clock	
Backlight Type	LED , White	

## 4. Absolute Maximum Ratings

Item	Symbol	Min	Typ	Max	Unit
Operating Temperature	$T_{OP}$	-20	—	+70	°C
Storage Temperature	$T_{ST}$	-30	—	+80	°C
Input Voltage	$V_I$	$V_{SS}$	—	$V_{DD}$	V
Supply Voltage For Logic	$V_{DD}-V_{SS}$	-0.3	—	7	V
Supply Voltage For LCD	$V_{DD}-V_0$	-0.3	—	13	V

## 5. Electrical Characteristics

Item	Symbol	Condition	Min	Typ	Max	Unit
Supply Voltage For Logic	$V_{DD}-V_{SS}$	—	4.5	5.0	5.5	V
Supply Voltage For LCD	$V_{DD}-V_0$	$T_a=-20^{\circ}\text{C}$	—	—	5.2	V
*Note		$T_a=25^{\circ}\text{C}$	—	3.7	—	V
		$T_a=70^{\circ}\text{C}$	3.2	—	—	V
Input High Volt.	$V_{IH}$	—	$0.7V_{DD}$	—	$V_{DD}$	V
Input Low Volt.	$V_{IL}$	—	$V_{SS}$	—	0.6	V
Output High Volt.	$V_{OH}$	—	3.9	—	—	V
Output Low Volt.	$V_{OL}$	—	—	—	0.4	V
Supply Current	$I_{DD}$	$V_{DD}=5\text{V}$	—	1.2	—	mA

\* Note: Please design the VOP adjustment circuit on customer's main board

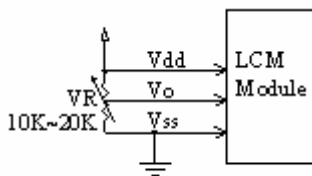

# 6. Optical Characteristics

Item	Symbol	Condition	Min	Typ	Max	Unit
View Angle	(V) $\theta$	$CR \geq 2$	20	—	40	deg
	(H) $\varphi$	$CR \geq 2$	-30	—	30	deg
Contrast Ratio	CR	—	—	3	—	—
Response Time	T rise	—	—	150	200	ms
	T fall	—	—	150	200	ms

## Definition of Operation Voltage (Vop)

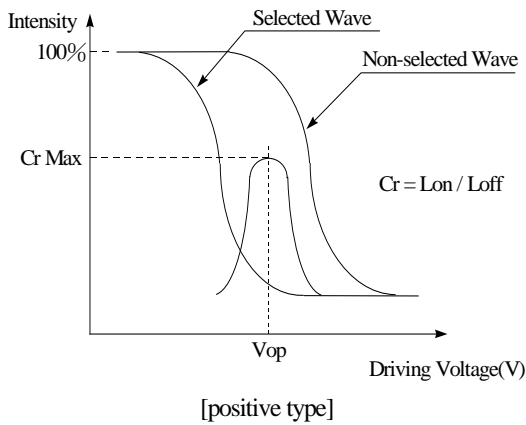

## Definition of Response Time (Tr, Tf)

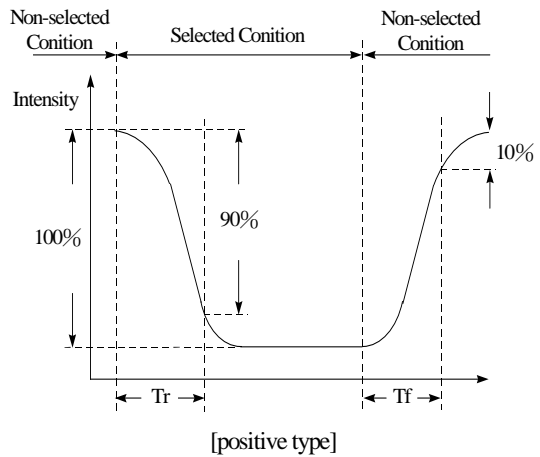

### Conditions :

Operating Voltage : Vop      Viewing Angle( $\theta$  ,  $\varphi$ ) :  $0^\circ$  ,  $0^\circ$   
 Frame Frequency : 64 HZ      Driving Waveform : 1/N duty , 1/a bias

## Definition of viewing angle( $CR \geq 2$ )

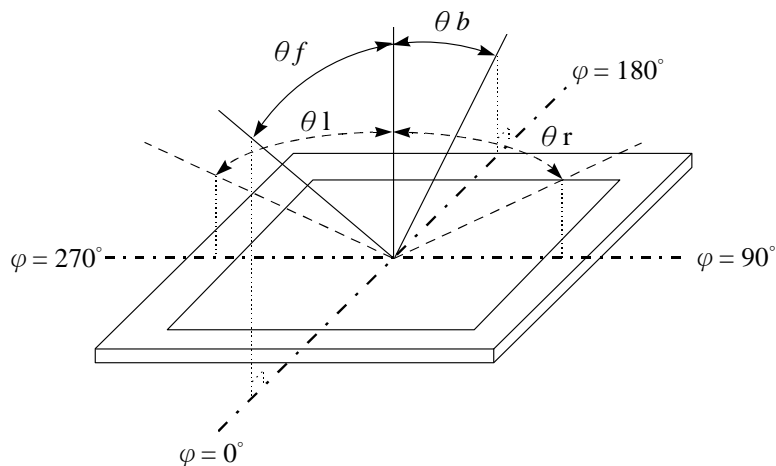

# 7.Interface Pin Function

Pin No.	Symbol	Level	Description
1	V <sub>SS</sub>	0V	Ground
2	V <sub>DD</sub>	5.0V	Supply Voltage for logic
3	VO	(Variable)	Operating voltage for LCD
4	RS	H/L	H: DATA, L: Instruction code
5	R/W	H/L	H: Read(MPU→Module) L: Write(MPU→Module)
6	E	H,H→L	Chip enable signal
7	DB0	H/L	Data bus line
8	DB1	H/L	Data bus line
9	DB2	H/L	Data bus line
10	DB3	H/L	Data bus line
11	DB4	H/L	Data bus line
12	DB5	H/L	Data bus line
13	DB6	H/L	Data bus line
14	DB7	H/L	Data bus line
15	A	—	LED +
16	K	—	LED —



# 8. Contour Drawing & Block Diagram

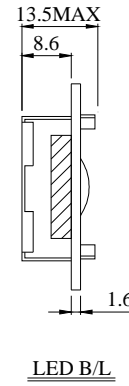
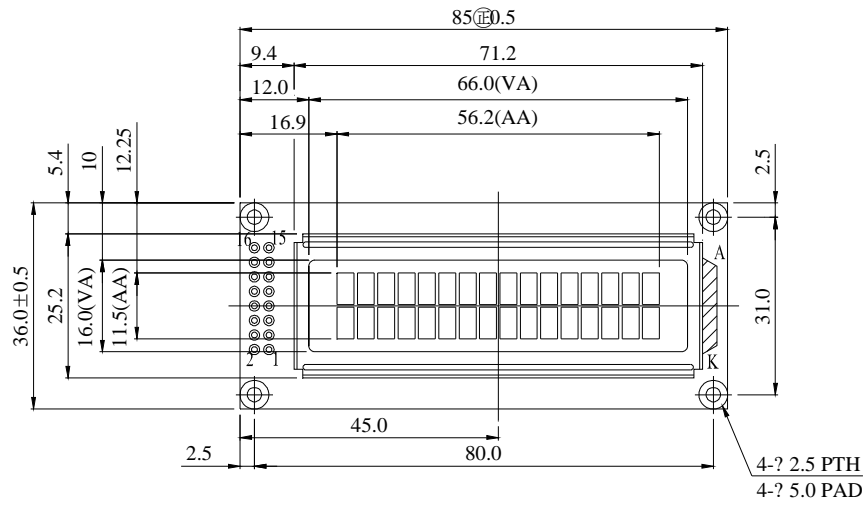

PIN NO.	SYMBOL
1	V <sub>SS</sub>
2	V <sub>DD</sub>
3	V <sub>O</sub>
4	RS
5	R/W
6	E
7	DB0
8	DB1
9	DB2
10	DB3
11	DB4
12	DB5
13	DB6
14	DB7
15	A
16	K

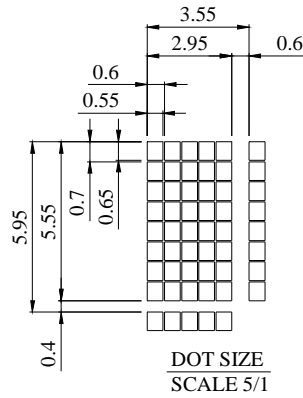
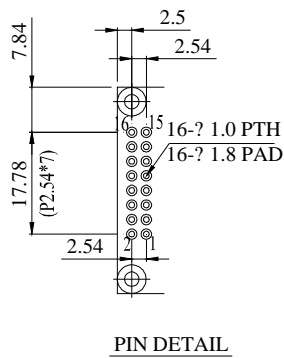

The non-specified tolerance of dimension is ±0.3mm.

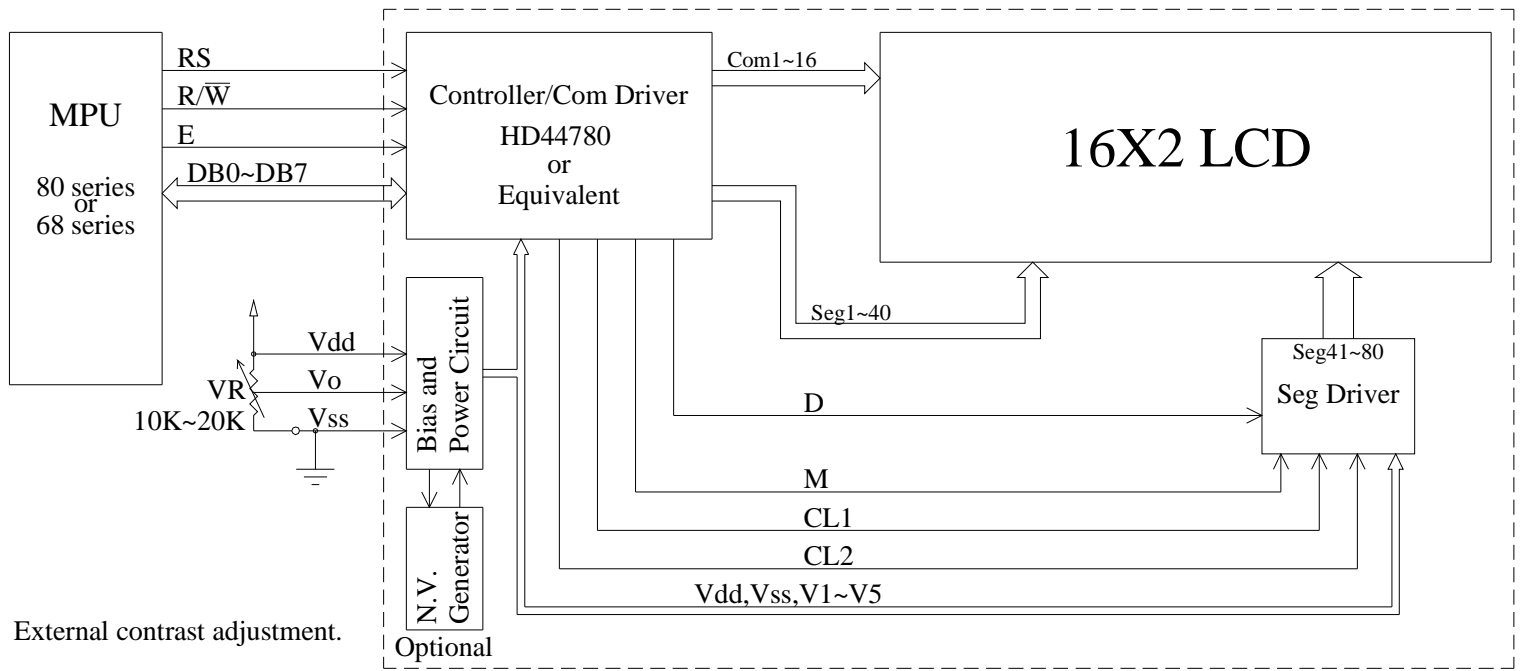

Character located	1	2	3	4	5	6	7	8	9	10	11	12	13	14	15	16
DDRAM address	00	01	02	03	04	05	06	07	08	09	0A	0B	0C	0D	0E	0F
DDRAM address	40	41	42	43	44	45	46	47	48	49	4A	4B	4C	4D	4E	4F

# 9. Function Description

The LCD display Module is built in a LSI controller, the controller has two 8-bit registers, an instruction register (IR) and a data register (DR).

The IR stores instruction codes, such as display clear and cursor shift, and address information for display data RAM (DDRAM) and character generator (CGRAM). The IR can only be written from the MPU. The DR temporarily stores data to be written or read from DDRAM or CGRAM. When address information is written into the IR, then data is stored into the DR from DDRAM or CGRAM. By the register selector (RS) signal, these two registers can be selected.

RS	R/W	Operation
0	0	IR write as an internal operation (display clear, etc.)
0	1	Read busy flag (DB7) and address counter (DB0 to DB7)
1	0	Write data to DDRAM or CGRAM (DR to DDRAM or CGRAM)
1	1	Read data from DDRAM or CGRAM (DDRAM or CGRAM to DR)

### Busy Flag (BF)

When the busy flag is 1, the controller LSI is in the internal operation mode, and the next instruction will not be accepted. When RS=0 and R/W=1, the busy flag is output to DB7. The next instruction must be written after ensuring that the busy flag is 0.

### Address Counter (AC)

The address counter (AC) assigns addresses to both DDRAM and CGRAM

### Display Data RAM (DDRAM)

This DDRAM is used to store the display data represented in 8-bit character codes. Its extended capacity is 80x8 bits or 80 characters. Below figure is the relationships between DDRAM addresses and positions on the liquid crystal display.

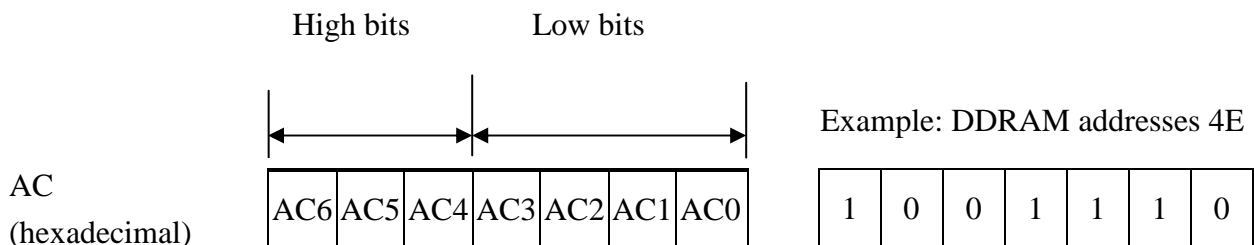

Display position DDRAM address

1	2	3	4	5	6	7	8	9	10	11	12	13	14	15	16
00	01	02	03	04	05	06	07	08	09	0A	0B	0C	0D	0E	0F
40	41	42	43	44	45	46	47	48	49	4A	4B	4C	4D	4E	4F

2-Line by 16-Character Display

**Character Generator ROM (CGROM)**

The CGROM generate 5×8 dot or 5×10 dot character patterns from 8-bit character codes. See Table 2.

**Character Generator RAM (CGRAM)**

In CGRAM, the user can rewrite character by program. For 5×8 dots, eight character patterns can be written, and for 5×10 dots, four character patterns can be written.

Write into DDRAM the character code at the addresses shown as the left column of table 1. To show the character patterns stored in CGRAM.

# Relationship between CGRAM Addresses, Character Codes (DDRAM) and Character patterns

**Table 1.**

For 5 \* 8 dot character patterns

Character Codes (DDRAM data)								CGRAM Address						Character Patterns (CGRAM data)																																									
7	6	5	4	3	2	1	0	5			4			3			2			1			0																																
High				Low				High			Low			High				Low																																					
0 0 0 0 * 0 0 0								0 0 0						0 0 0	*	*	*	0				0				Character pattern( 1 )																													
														0 0 1	*	*	*	0 0 0				0																																	
														0 1 0	*	*	*	0 0 0				0																																	
														0 1 1	*	*	*	0				0																																	
														1 0 0	*	*	*	0				0																																	
														1 0 1	*	*	*	0 0				0																																	
														1 1 0	*	*	*	0 0 0				0																																	
														1 1 1	*	*	*	0 0 0 0 0				0																																	
														0 0 0	*	*	*	0 0 0 0				0																																	
														0 0 1	*	*	*	0				0																																	
0 0 0 0 * 0 0 1								0 0 1						0 1 0	*	*	*	0				0				Character pattern( 2 )																													
														0 1 1	*	*	*	0 0				0 0																																	
														1 0 0	*	*	*	0 0 0				0 0																																	
														1 0 1	*	*	*	0 0				0 0																																	
														1 1 0	*	*	*	0 0 0 0				0 0																																	
														1 1 1	*	*	*	0 0 0 0 0				0 0																																	
																												0 0 0	*	*	*									Cursor pattern															
																												0 0 1	*	*	*																								
																												0 0 0 0 * 1 1 1								1 1 1						1 0 0	*	*	*										
																																										1 0 1	*	*	*										
1 1 0	*	*	*																																																				
1 1 1	*	*	*																																																				

For 5 \* 10 dot character patterns

Character Codes (DDRAM data)										CGRAM Address										Character Patterns (CGRAM data)																			
7	6	5	4	3	2	1	0	5					4					3					2					1					0						
High					Low					High					Low					High					Low														
0 0 0 0 * 0 0 0										0 0										0 0 0 0 0	*	*	*	0					0 0 0 0 0					0					Character pattern
																				0 0 0 0 1	*	*	*	0 0 0 0 0					0 0										
																				0 0 1 0 0	*	*	*	0					0 0										
																				0 0 1 1 1	*	*	*	0 0 0					0										
																				0 1 0 0 0	*	*	*	0 0 0 0					0										
																				0 1 0 1 1	*	*	*	0 0 0 0					0										
																				0 1 1 1 0	*	*	*	0 0 0 0 0					0										
																				1 0 0 0 0	*	*	*	0 0 0 0 0					0										
																				1 0 0 1 1	*	*	*	0 0 0 0 0					0										
																				1 0 1 0 0	*	*	*	0 0 0 0 0					0										
																				1 1 1 1 1	*	*	*						* * * * *					* * * * *					Cursor pattern

■ : " High "

# 10.Character Generator ROM Pattern

Table.2

Upper 4 bit Lower 4 bit	LLLL	LLLH	LLHL	LLHH	LHLL	LHLH	LHHL	LHHH	HLLL	HLLH	HLHL	HLHH	HHLL	HHLH	HHHL	HHHH
LLLL	CG RAM (1)			0	1	2	3	4			5	6	7	8	9	.
LLLH	CG RAM (2)		!	0	1	2	3	4			5	6	7	8	9	.
LLHL	CG RAM (3)		"	0	1	2	3	4			5	6	7	8	9	.
LLHH	CG RAM (4)		#	0	1	2	3	4			5	6	7	8	9	.
LHLL	CG RAM (5)		\$	0	1	2	3	4			5	6	7	8	9	.
LHLH	CG RAM (6)		%	0	1	2	3	4			5	6	7	8	9	.
LHHL	CG RAM (7)		&	0	1	2	3	4			5	6	7	8	9	.
LHHH	CG RAM (8)		'	0	1	2	3	4			5	6	7	8	9	.
HLLL	CG RAM (1)		(	0	1	2	3	4			5	6	7	8	9	.
HLLH	CG RAM (2)		)	0	1	2	3	4			5	6	7	8	9	.
HLHL	CG RAM (3)		*	0	1	2	3	4			5	6	7	8	9	.
HLHH	CG RAM (4)		+	0	1	2	3	4			5	6	7	8	9	.
HHLL	CG RAM (5)		,	0	1	2	3	4			5	6	7	8	9	.
HHLH	CG RAM (6)		-	0	1	2	3	4			5	6	7	8	9	.
HHHL	CG RAM (7)		.	0	1	2	3	4			5	6	7	8	9	.
HHHH	CG RAM (8)		/	0	1	2	3	4			5	6	7	8	9	.

# 11. Instruction Table

Instruction	Instruction Code										Description	Execution time (fosc=270Khz)	
	RS	R/W	DB7	DB6	DB5	DB4	DB3	DB2	DB1	DB0			
Clear Display	0	0	0	0	0	0	0	0	0	0	1	Write "20H" to DDRAM. and set DDRAM address to "00H" from AC	1.52ms
Return Home	0	0	0	0	0	0	0	0	0	1	—	Set DDRAM address to "00H" from AC and return cursor to its original position if shifted. The contents of DDRAM are not changed.	1.52ms
Entry Mode Set	0	0	0	0	0	0	0	0	1	I/D	SH	Sets cursor move direction and specifies display shift. These operations are performed during data write and read.	37 $\mu$ s
Display ON/OFF Control	0	0	0	0	0	0	0	1	D	C	B	D=1:entire display on C=1:cursor on B=1:cursor position on	37 $\mu$ s
Cursor or Display Shift	0	0	0	0	0	0	1	S/C	R/L	—	—	Set cursor moving and display shift control bit, and the direction, without changing DDRAM data.	37 $\mu$ s
Function Set	0	0	0	0	0	1	DL	N	F	—	—	DL:interface data is 8/4 bits N:number of line is 2/1 F:font size is 5x11/5x8	37 $\mu$ s
Set CGRAM Address	0	0	0	1	AC5	AC4	AC3	AC2	AC1	AC0		Set CGRAM address in address counter	37 $\mu$ s
Set DDRAM Address	0	0	1	AC6	AC5	AC4	AC3	AC2	AC1	AC0		Set DDRAM address in address counter	37 $\mu$ s
Read Busy Flag and Address	0	1	BF	AC6	AC5	AC4	AC3	AC2	AC1	AC0		Whether during internal operation or not can be known by reading BF. The contents of address counter can also be read.	0 $\mu$ s
Write Data to RAM	1	0	D7	D6	D5	D4	D3	D2	D1	D0		Write data into internal RAM (DDRAM/CGRAM)	37 $\mu$ s
Read Data from RAM	1	1	D7	D6	D5	D4	D3	D2	D1	D0		Read data from internal RAM (DDRAM/CGRAM)	37 $\mu$ s

\* "—" : don't care

# 12. Timing Characteristics

## 12.1 Writing data from MPU to ST7066U

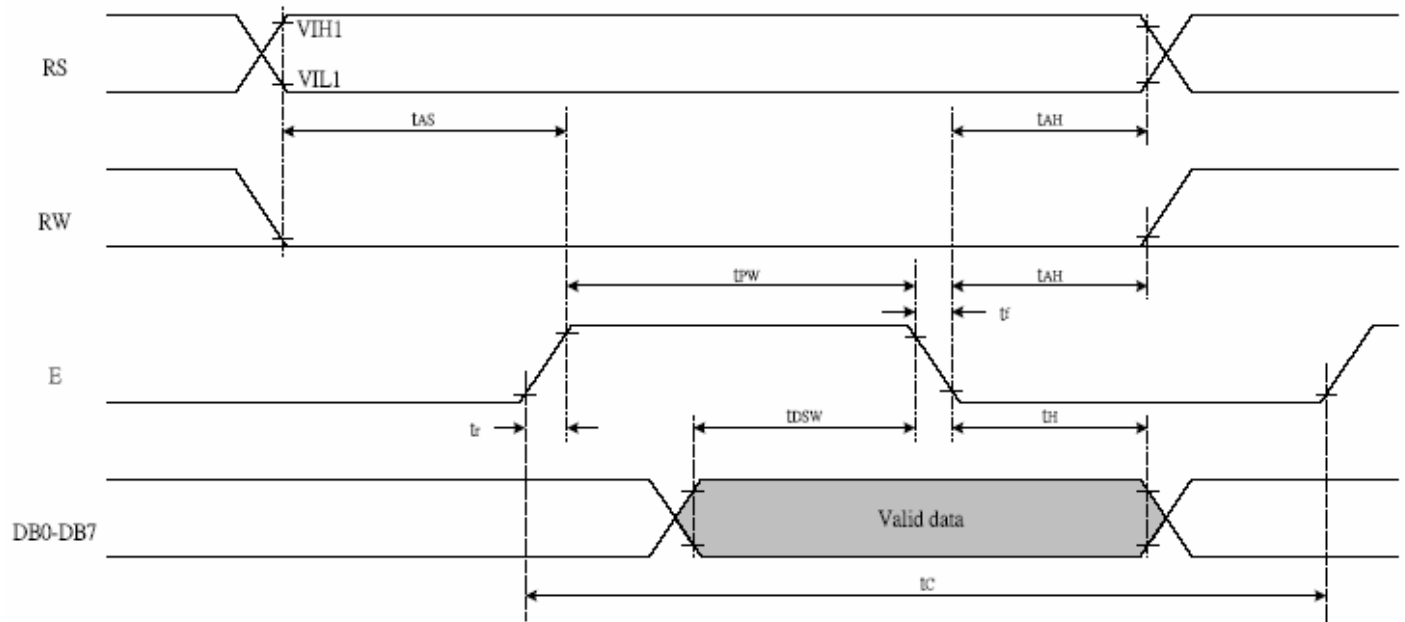

Ta=-30~+85°C, VDD=5.0±

0.5V

TC	Enable Cycle Time	Pin E	1200	-	-	ns
TPW	Enable Pulse Width	Pin E	140	-	-	ns
TR,TF	Enable Rise/Fall Time	Pin E	-	-	25	ns
TAS	Address Setup Time	Pins: RS,RW,E	0	-	-	ns
TAH	Address Hold Time	Pins: RS,RW,E	10	-	-	ns
TDSW	Data Setup Time	Pins: DB0 - DB7	40	-	-	ns
TH	Data Hold Time	Pins: DB0 - DB7	10	-	-	ns



## 12.2 Reading data from ST7066U to MPU

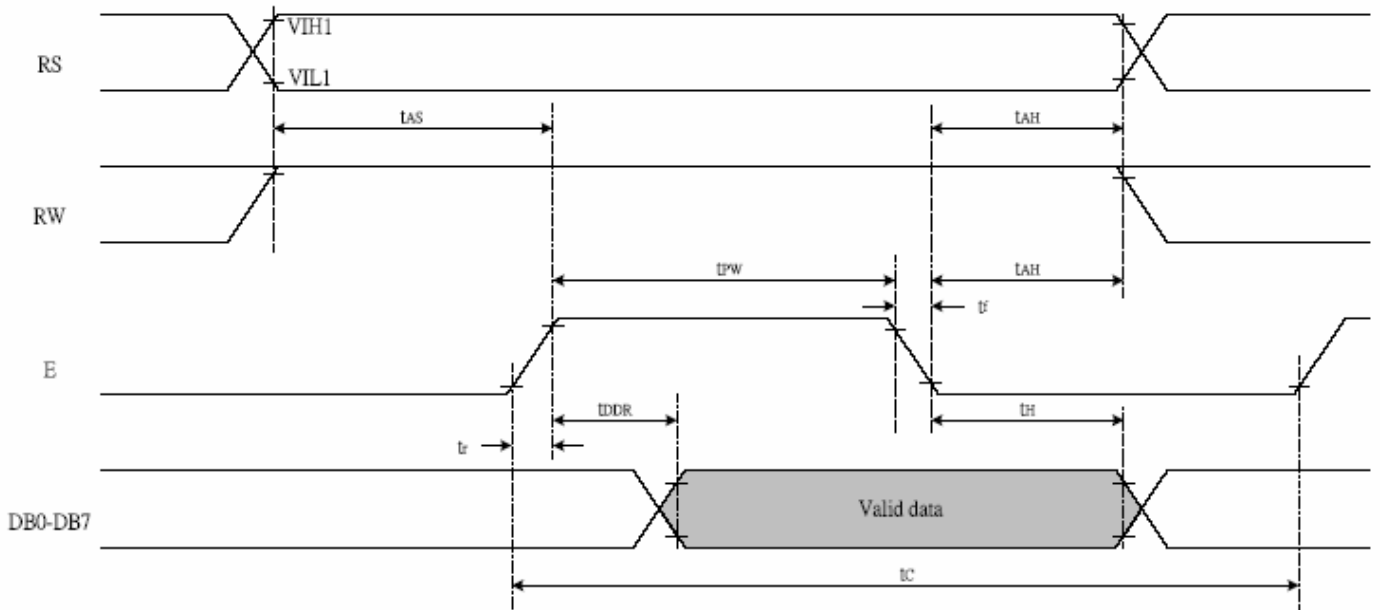

Ta=-30~+85°C, VDD=5.0±

0.5V

Read Mode		(Reading Data from ST7066U to MPU)				
TC	Enable Cycle Time	Pin E	1200	-	-	ns
TPW	Enable Pulse Width	Pin E	140	-	-	ns
TR,TF	Enable Rise/Fall Time	Pin E	-	-	25	ns
TAS	Address Setup Time	Pins: RS,RW,E	0	-	-	ns
TAH	Address Hold Time	Pins: RS,RW,E	10	-	-	ns
TDDR	Data Setup Time	Pins: DB0 - DB7	-	-	100	ns
TH	Data Hold Time	Pins: DB0 - DB7	10	-	-	ns

# 13. Initializing of LCM

- 4-bit Interface (fosc=270KHz)

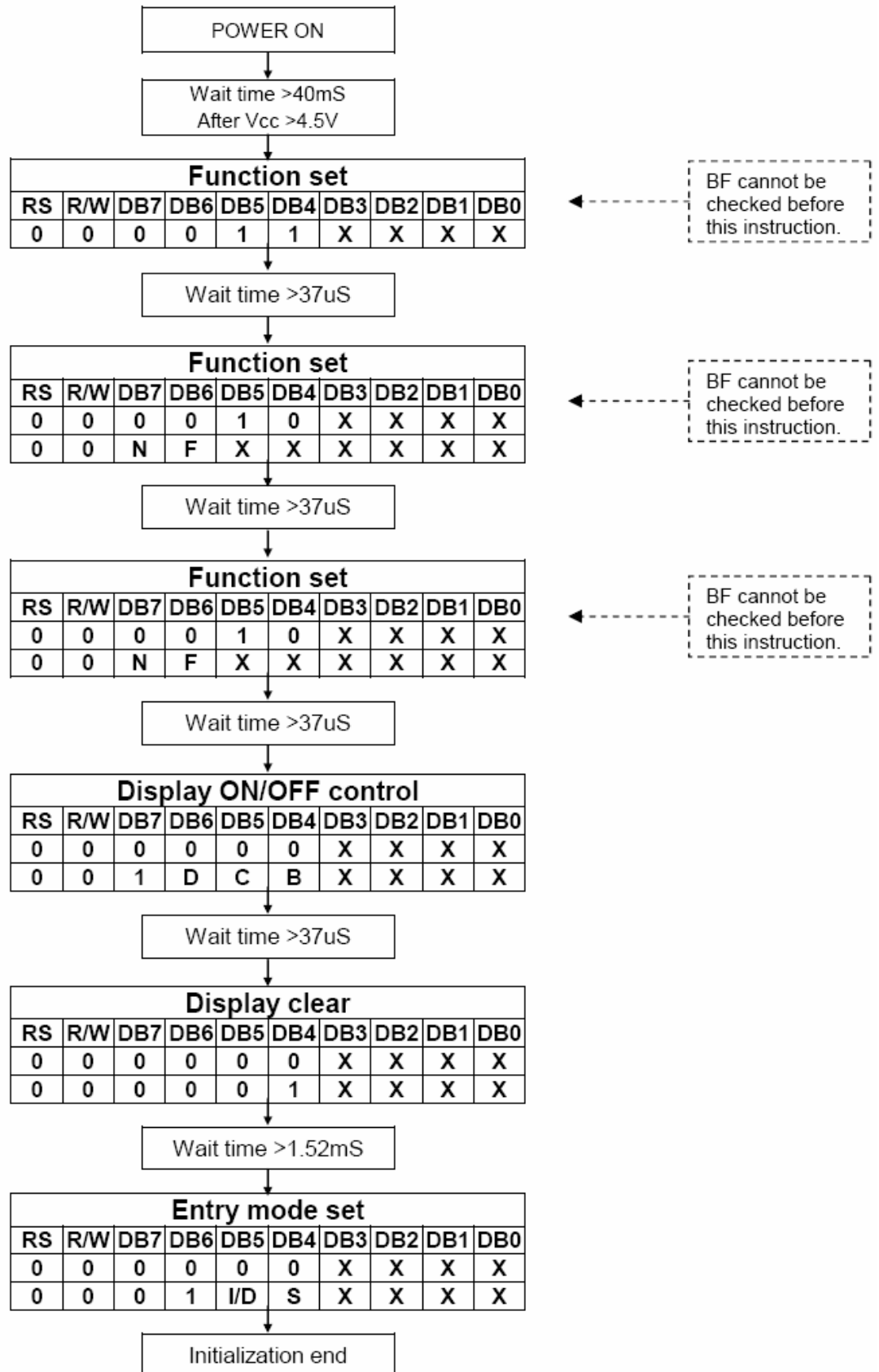

● 8-bit Interface ( $f_{osc}=270\text{KHz}$ )

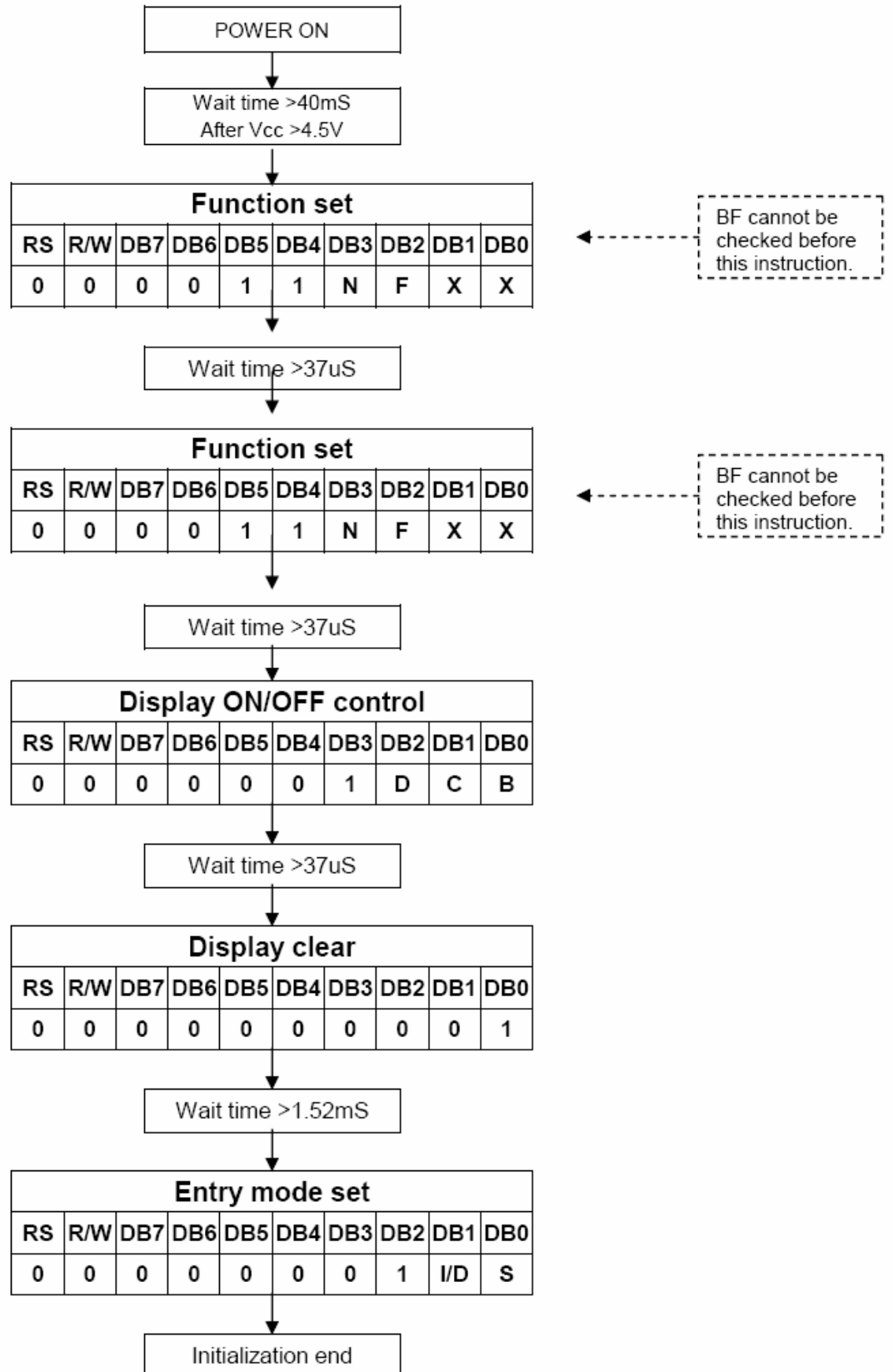

# 14. Reliability

## Content of Reliability Test (wide temperature, -20°C~70°C)

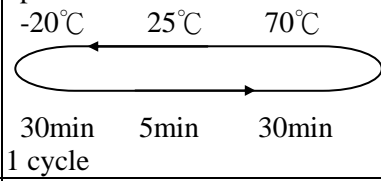
Environmental Test			
Test Item	Content of Test	Test Condition	Note
High Temperature storage	Endurance test applying the high storage temperature for a long time.	80°C 200hrs	2
Low Temperature storage	Endurance test applying the high storage temperature for a long time.	-30°C 200hrs	1,2
High Temperature Operation	Endurance test applying the electric stress (Voltage & Current) and the thermal stress to the element for a long time.	70°C 200hrs	—
Low Temperature Operation	Endurance test applying the electric stress under low temperature for a long time.	-20°C 200hrs	1
High Temperature/ Humidity Operation	The module should be allowed to stand at 60°C, 90%RH max For 96hrs under no-load condition excluding the polarizer, Then taking it out and drying it at normal temperature.	60°C, 90%RH 96hrs	1,2
Thermal shock resistance	The sample should be allowed stand the following 10 cycles of operation  30min 5min 30min 1 cycle	-20°C/70°C 10 cycles	—
Vibration test	Endurance test applying the vibration during transportation and using.	Total fixed amplitude : 1.5mm Vibration Frequency : 10~55Hz One cycle 60 seconds to 3 directions of X, Y, Z for Each 15 minutes	3
Static electricity test	Endurance test applying the electric stress to the terminal.	VS=800V, RS=1.5kΩ CS=100pF 1 time	—

**Note1: No dew condensation to be observed.**

**Note2: The function test shall be conducted after 4 hours storage at the normal Temperature and humidity after remove from the test chamber.**

**Note3: Vibration test will be conducted to the product itself without putting it in a container.**

# 15.Backlight Information

## Specification

PARAMETER	SYMBOL	MIN	TYP	MAX	UNIT	TEST CONDITION
Supply Current	I <sub>LED</sub>	—	32	40	mA	V=3.5V
Supply Voltage	V	3.4	3.5	3.6	V	—
Reverse Voltage	V <sub>R</sub>	—	—	5	V	—
Luminous Intensity	I <sub>V</sub>	400	500	—	CD/M2	I <sub>LED</sub> =32mA
LED Life Time (For Reference only)	—	—	50K	—	Hr.	I <sub>LED</sub> =32mA 25°C,50-60%RH, (Note 1)
Color	White					

**Note:** The LED of B/L is drive by current only, drive voltage is for reference only. drive voltage can make driving current under safety area (current between minimum and maximum).

**Note 1:**50K hours is only an estimate for reference.

2.Drive from pin15,pin16

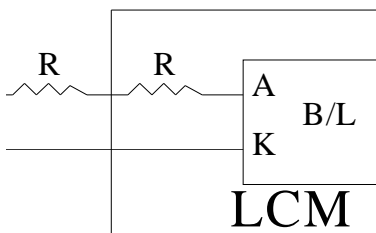

ill never get Vee output from pin15)

# 16. Inspection specification

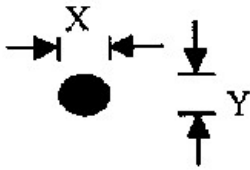
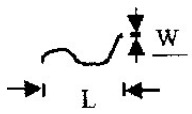
NO	Item	Criterion	AQL												
01	Electrical Testing	1.1 Missing vertical, horizontal segment, segment contrast defect. 1.2 Missing character , dot or icon. 1.3 Display malfunction. 1.4 No function or no display. 1.5 Current consumption exceeds product specifications. 1.6 LCD viewing angle defect. 1.7 Mixed product types. 1.8 Contrast defect.	0.65												
02	Black or white spots on LCD (display only)	2.1 White and black spots on display $\leq 0.25\text{mm}$ , no more than three white or black spots present. 2.2 Densely spaced: No more than two spots or lines within 3mm	2.5												
03	LCD black spots, white spots, contamination (non-display)	3.1 Round type : As following drawing $\Phi = (x + y) / 2$  <table border="1" data-bbox="849 1025 1331 1288"> <thead> <tr> <th>SIZE</th> <th>Acceptable Q TY</th> </tr> </thead> <tbody> <tr> <td><math>\Phi \leq 0.10</math></td> <td>Accept no dense</td> </tr> <tr> <td><math>0.10 &lt; \Phi \leq 0.20</math></td> <td>2</td> </tr> <tr> <td><math>0.20 &lt; \Phi \leq 0.25</math></td> <td>1</td> </tr> <tr> <td><math>0.25 &lt; \Phi</math></td> <td>0</td> </tr> </tbody> </table>	SIZE	Acceptable Q TY	$\Phi \leq 0.10$	Accept no dense	$0.10 < \Phi \leq 0.20$	2	$0.20 < \Phi \leq 0.25$	1	$0.25 < \Phi$	0	2.5		
		SIZE	Acceptable Q TY												
$\Phi \leq 0.10$	Accept no dense														
$0.10 < \Phi \leq 0.20$	2														
$0.20 < \Phi \leq 0.25$	1														
$0.25 < \Phi$	0														
3.2 Line type : (As following drawing)  <table border="1" data-bbox="683 1393 1331 1653"> <thead> <tr> <th>Length</th> <th>Width</th> <th>Acceptable Q TY</th> </tr> </thead> <tbody> <tr> <td>---</td> <td><math>W \leq 0.02</math></td> <td>Accept no dense</td> </tr> <tr> <td><math>L \leq 3.0</math></td> <td><math>0.02 &lt; W \leq 0.03</math></td> <td rowspan="2">2</td> </tr> <tr> <td><math>L \leq 2.5</math></td> <td><math>0.03 &lt; W \leq 0.05</math></td> </tr> <tr> <td>---</td> <td><math>0.05 &lt; W</math></td> <td>As round type</td> </tr> </tbody> </table>	Length	Width	Acceptable Q TY	---	$W \leq 0.02$	Accept no dense	$L \leq 3.0$	$0.02 < W \leq 0.03$	2	$L \leq 2.5$	$0.03 < W \leq 0.05$	---	$0.05 < W$	As round type	2.5
Length	Width	Acceptable Q TY													
---	$W \leq 0.02$	Accept no dense													
$L \leq 3.0$	$0.02 < W \leq 0.03$	2													
$L \leq 2.5$	$0.03 < W \leq 0.05$														
---	$0.05 < W$	As round type													
04	Polarizer bubbles	If bubbles are visible, judge using black spot specifications, not easy to find, must check in specify direction. <table border="1" data-bbox="817 1713 1331 2016"> <thead> <tr> <th>Size <math>\Phi</math></th> <th>Acceptable Q TY</th> </tr> </thead> <tbody> <tr> <td><math>\Phi \leq 0.20</math></td> <td>Accept no dense</td> </tr> <tr> <td><math>0.20 &lt; \Phi \leq 0.50</math></td> <td>3</td> </tr> <tr> <td><math>0.50 &lt; \Phi \leq 1.00</math></td> <td>2</td> </tr> <tr> <td><math>1.00 &lt; \Phi</math></td> <td>0</td> </tr> <tr> <td>Total Q TY</td> <td>3</td> </tr> </tbody> </table>	Size $\Phi$	Acceptable Q TY	$\Phi \leq 0.20$	Accept no dense	$0.20 < \Phi \leq 0.50$	3	$0.50 < \Phi \leq 1.00$	2	$1.00 < \Phi$	0	Total Q TY	3	2.5
Size $\Phi$	Acceptable Q TY														
$\Phi \leq 0.20$	Accept no dense														
$0.20 < \Phi \leq 0.50$	3														
$0.50 < \Phi \leq 1.00$	2														
$1.00 < \Phi$	0														
Total Q TY	3														

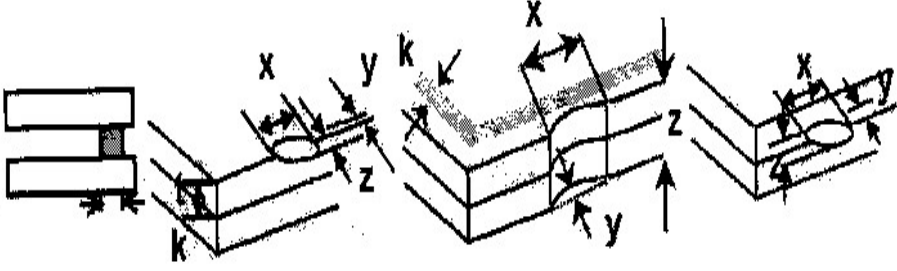
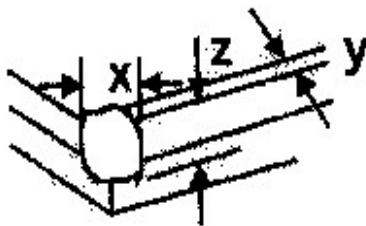
NO	Item	Criterion	AQL																		
05	Scratches	Follow NO.3 LCD black spots, white spots, contamination																			
06	Chipped glass	<p>Symbols Define:  x: Chip length      y: Chip width      z: Chip thickness  k: Seal width      t: Glass thickness      a: LCD side length  L: Electrode pad length:</p> <p>6.1 General glass chip :  6.1.1 Chip on panel surface and crack between panels:</p>  <table border="1" data-bbox="416 896 1331 1052"> <tr> <td>z: Chip thickness</td> <td>y: Chip width</td> <td>x: Chip length</td> </tr> <tr> <td><math>Z \leq 1/2t</math></td> <td>Not over viewing area</td> <td><math>x \leq 1/8a</math></td> </tr> <tr> <td><math>1/2t &lt; z \leq 2t</math></td> <td>Not exceed 1/3k</td> <td><math>x \leq 1/8a</math></td> </tr> </table> <p>⊙ If there are 2 or more chips, x is total length of each chip.</p> <p>6.1.2 Corner crack:</p>  <table border="1" data-bbox="416 1444 1331 1601"> <tr> <td>z: Chip thickness</td> <td>y: Chip width</td> <td>x: Chip length</td> </tr> <tr> <td><math>Z \leq 1/2t</math></td> <td>Not over viewing area</td> <td><math>x \leq 1/8a</math></td> </tr> <tr> <td><math>1/2t &lt; z \leq 2t</math></td> <td>Not exceed 1/3k</td> <td><math>x \leq 1/8a</math></td> </tr> </table> <p>⊙ If there are 2 or more chips, x is the total length of each chip.</p>	z: Chip thickness	y: Chip width	x: Chip length	$Z \leq 1/2t$	Not over viewing area	$x \leq 1/8a$	$1/2t < z \leq 2t$	Not exceed 1/3k	$x \leq 1/8a$	z: Chip thickness	y: Chip width	x: Chip length	$Z \leq 1/2t$	Not over viewing area	$x \leq 1/8a$	$1/2t < z \leq 2t$	Not exceed 1/3k	$x \leq 1/8a$	2.5
z: Chip thickness	y: Chip width	x: Chip length																			
$Z \leq 1/2t$	Not over viewing area	$x \leq 1/8a$																			
$1/2t < z \leq 2t$	Not exceed 1/3k	$x \leq 1/8a$																			
z: Chip thickness	y: Chip width	x: Chip length																			
$Z \leq 1/2t$	Not over viewing area	$x \leq 1/8a$																			
$1/2t < z \leq 2t$	Not exceed 1/3k	$x \leq 1/8a$																			

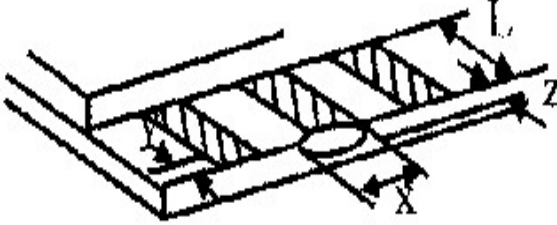
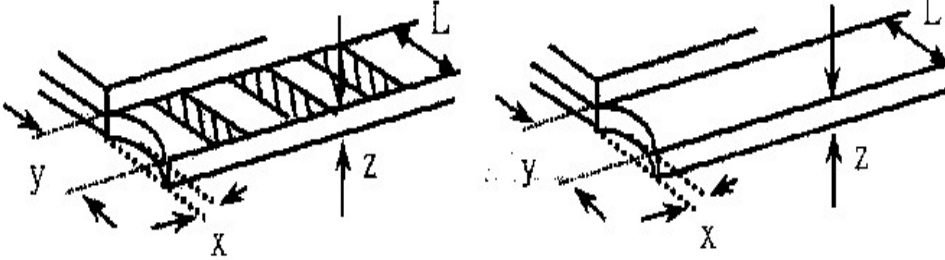
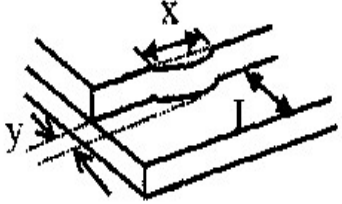
NO	Item	Criterion	AQL																
06	Glass crack	<p>Symbols :</p> <p>x: Chip length      y: Chip width      z: Chip thickness  k: Seal width      t: Glass thickness      a: LCD side length  L: Electrode pad length</p> <p>6.2 Protrusion over terminal :</p> <p>6.2.1 Chip on electrode pad :</p>  <table border="1" data-bbox="331 712 1228 913"> <tr> <td>y: Chip width</td> <td>x: Chip length</td> <td>z: Chip thickness</td> </tr> <tr> <td><math>y \leq 0.5\text{mm}</math></td> <td><math>x \leq 1/8a</math></td> <td><math>0 &lt; z \leq t</math></td> </tr> </table> <p>6.2.2 Non-conductive portion:</p>  <table border="1" data-bbox="399 1249 1228 1451"> <tr> <td>y: Chip width</td> <td>x: Chip length</td> <td>z: Chip thickness</td> </tr> <tr> <td><math>y \leq L</math></td> <td><math>x \leq 1/8a</math></td> <td><math>0 &lt; z \leq t</math></td> </tr> </table> <p>⊙If the chipped area touches the ITO terminal, over 2/3 of the ITO must remain and be inspected according to electrode terminal specifications.  ⊙If the product will be heat sealed by the customer, the alignment mark not be damaged.</p> <p>6.2.3 Substrate protuberance and internal crack.</p>  <table border="1" data-bbox="742 1680 1241 1881"> <tr> <td>y: width</td> <td>x: length</td> </tr> <tr> <td><math>y \leq 1/3L</math></td> <td><math>x \leq a</math></td> </tr> </table>	y: Chip width	x: Chip length	z: Chip thickness	$y \leq 0.5\text{mm}$	$x \leq 1/8a$	$0 < z \leq t$	y: Chip width	x: Chip length	z: Chip thickness	$y \leq L$	$x \leq 1/8a$	$0 < z \leq t$	y: width	x: length	$y \leq 1/3L$	$x \leq a$	2.5
y: Chip width	x: Chip length	z: Chip thickness																	
$y \leq 0.5\text{mm}$	$x \leq 1/8a$	$0 < z \leq t$																	
y: Chip width	x: Chip length	z: Chip thickness																	
$y \leq L$	$x \leq 1/8a$	$0 < z \leq t$																	
y: width	x: length																		
$y \leq 1/3L$	$x \leq a$																		

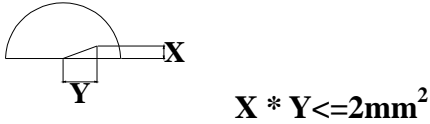

NO	Item	Criterion	AQL
07	Cracked glass	The LCD with extensive crack is not acceptable.	2.5
08	Backlight elements	8.1 Illumination source flickers when lit. 8.2 Spots or scratched that appear when lit must be judged. Using LCD spot, lines and contamination standards. 8.3 Backlight doesn't light or color wrong.	0.65 2.5 0.65
09	Bezel	9.1 Bezel may not have rust, be deformed or have fingerprints, stains or other contamination. 9.2 Bezel must comply with job specifications.	2.5 0.65
10	PCB、COB	10.1 COB seal may not have pinholes larger than 0.2mm or contamination. 10.2 COB seal surface may not have pinholes through to the IC. 10.3 The height of the COB should not exceed the height indicated in the assembly diagram. 10.4 There may not be more than 2mm of sealant outside the seal area on the PCB. And there should be no more than three places. 10.5 No oxidation or contamination PCB terminals. 10.6 Parts on PCB must be the same as on the production characteristic chart. There should be no wrong parts, missing parts or excess parts. 10.7 The jumper on the PCB should conform to the product characteristic chart. 10.8 If solder gets on bezel tab pads, LED pad, zebra pad or screw hold pad, make sure it is smoothed down. 10.9 The Scraping testing standard for Copper Coating of PCB  $X * Y \leq 2\text{mm}^2$	2.5 2.5 0.65 2.5 2.5 0.65 0.65 2.5 2.5
11	Soldering	11.1 No un-melted solder paste may be present on the PCB. 11.2 No cold solder joints, missing solder connections, oxidation or icicle. 11.3 No residue or solder balls on PCB. 11.4 No short circuits in components on PCB.	2.5 2.5 2.5 0.65

NO	Item	Criterion	AQL
12	General appearance	12.1 No oxidation, contamination, curves or, bends on interface Pin (OLB) of TCP.	2.5
		12.2 No cracks on interface pin (OLB) of TCP.	0.65
		12.3 No contamination, solder residue or solder balls on product.	2.5
		12.4 The IC on the TCP may not be damaged, circuits.	2.5
		12.5 The uppermost edge of the protective strip on the interface pin must be present or look as if it cause the interface pin to sever.	2.5
		12.6 The residual rosin or tin oil of soldering (component or chip component) is not burned into brown or black color.	2.5
		12.7 Sealant on top of the ITO circuit has not hardened.	0.65
		12.8 Pin type must match type in specification sheet.	0.65
		12.9 LCD pin loose or missing pins.	0.65
		12.10 Product packaging must the same as specified on packaging specification sheet.	0.65
		12.11 Product dimension and structure must conform to product specification sheet.	

# 17. Material List of Components for RoHs

1. WINSTAR Display Co., Ltd hereby declares that all of or part of products (with the mark “#”in code), including, but not limited to, the LCM, accessories or packages, manufactured and/or delivered to your company (including your subsidiaries and affiliated company) directly or indirectly by our company (including our subsidiaries or affiliated companies) do not intentionally contain any of the substances listed in all applicable EU directives and regulations, including the following substances.

Exhibit A : The Harmful Material List

Material	(Cd)	(Pb)	(Hg)	(Cr6+)	PBBs	PBDEs
Limited Value	100 ppm	1000 ppm	1000 ppm	1000 ppm	1000 ppm	1000 ppm
Above limited value is set up according to RoHS.						

2.Process for RoHS requirement :

(1) Use the Sn/Ag/Cu soldering surface ; the surface of Pb-free solder is rougher than we used before.

(2) Heat-resistance temp. :

Reflow : 250°C,30 seconds Max. ;

Connector soldering wave or hand soldering : 320°C, 10 seconds max.

(3) Temp. curve of reflow, max. Temp. : 235±5°C ;

Recommended customer’s soldering temp. of connector : 280°C, 3 seconds.

# 18. Recommendable storage

1. Place the panel or module in the temperature 25°C±5°C and the humidity below 65% RH
2. Do not place the module near organics solvents or corrosive gases.
3. Do not crush, shake, or jolt the module



Module Number : \_\_\_\_\_

Page: 1

**1、Panel Specification :**

1. Panel Type :  Pass  NG , \_\_\_\_\_
2. View Direction :  Pass  NG , \_\_\_\_\_
3. Numbers of Dots :  Pass  NG , \_\_\_\_\_
4. View Area :  Pass  NG , \_\_\_\_\_
5. Active Area :  Pass  NG , \_\_\_\_\_
6. Operating Temperature :  Pass  NG , \_\_\_\_\_
7. Storage Temperature :  Pass  NG , \_\_\_\_\_
8. Others : \_\_\_\_\_

**2、Mechanical Specification :**

1. PCB Size :  Pass  NG , \_\_\_\_\_
2. Frame Size :  Pass  NG , \_\_\_\_\_
3. Material of Frame :  Pass  NG , \_\_\_\_\_
4. Connector Position :  Pass  NG , \_\_\_\_\_
5. Fix Hole Position :  Pass  NG , \_\_\_\_\_
6. Backlight Position :  Pass  NG , \_\_\_\_\_
7. Thickness of PCB :  Pass  NG , \_\_\_\_\_
8. Height of Frame to PCB :  Pass  NG , \_\_\_\_\_
9. Height of Module :  Pass  NG , \_\_\_\_\_
10. Others :  Pass  NG , \_\_\_\_\_

**3、Relative Hole Size :**

1. Pitch of Connector :  Pass  NG , \_\_\_\_\_
2. Hole size of Connector :  Pass  NG , \_\_\_\_\_
3. Mounting Hole size :  Pass  NG , \_\_\_\_\_
4. Mounting Hole Type :  Pass  NG , \_\_\_\_\_
5. Others :  Pass  NG , \_\_\_\_\_

**4、Backlight Specification :**

1. B/L Type :  Pass  NG , \_\_\_\_\_
2. B/L Color :  Pass  NG , \_\_\_\_\_
3. B/L Driving Voltage (Reference for LED Type) :  Pass  NG , \_\_\_\_\_
4. B/L Driving Current :  Pass  NG , \_\_\_\_\_
5. Brightness of B/L :  Pass  NG , \_\_\_\_\_
6. B/L Solder Method :  Pass  NG , \_\_\_\_\_
7. Others :  Pass  NG , \_\_\_\_\_

&gt;&gt; Go to page 2 &lt;&lt;



Module Number : \_\_\_\_\_

**5、Electronic Characteristics of Module :**

- 1. Input Voltage :  Pass  NG , \_\_\_\_\_
- 2. Supply Current :  Pass  NG , \_\_\_\_\_
- 3. Driving Voltage for LCD :  Pass  NG , \_\_\_\_\_
- 4. Contrast for LCD :  Pass  NG , \_\_\_\_\_
- 5. B/L Driving Method :  Pass  NG , \_\_\_\_\_
- 6. Negative Voltage Output :  Pass  NG , \_\_\_\_\_
- 7. Interface Function :  Pass  NG , \_\_\_\_\_
- 8. LCD Uniformity :  Pass  NG , \_\_\_\_\_
- 9. ESD test :  Pass  NG , \_\_\_\_\_
- 10. Others :  Pass  NG , \_\_\_\_\_

**6、Summary :**

Sales signature : \_\_\_\_\_

Customer Signature : \_\_\_\_\_

Date : \_\_\_\_ / \_\_\_\_ / \_\_\_\_