



SANG MAO

# SERIES B-1002A.B (1292A.B)



**B-1002A**

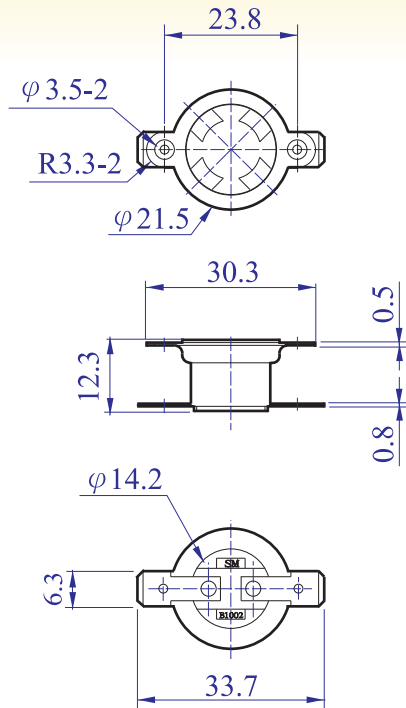

**B-1002B**

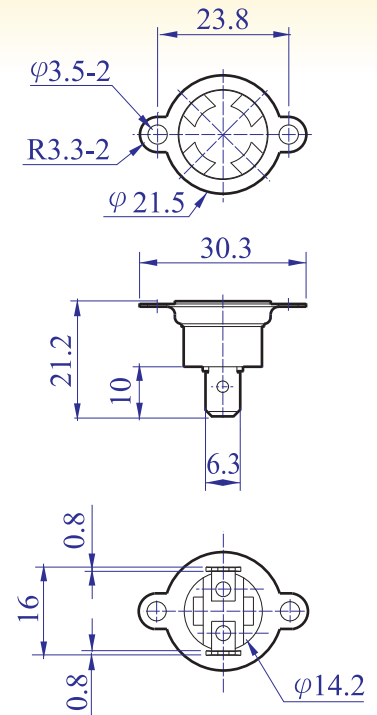

DIMENSION IN mm

## SPECIFICATIONS:

- \* TEMPERATURE RANGE: **45 - 165°C**
- \* OPERATING TOLERANCE: **±5°C, ±8°C, ±10°C**
- \* RESET DIFFERENTIAL: **10°C - 50°C**
- \* INPUT POWER: **32 VDC / 125 VAC / 250 VAC**
- \* CONTACTS TYPE: NORMALLY CLOSE / NORMALLY OPEN .
- \* CONTACTS ENDURANCE: (RESISTIVE LOAD)
  - 32VDC × 100mA -- 50,000 CYCLES**
  - 125VAC × 10A -- 100,000 CYCLES**
  - 125VAC × 15A -- 30,000 CYCLES**
  - 250VAC × 6A -- 30,000 CYCLES**
- \* INTERRUPT CAPACITY: **125VAC × 60A -- 5 CYCLES .**
- \* OVERSHOOT TEMPERATURE: **200°C / 5 MINUTES .**
- \* DIELECTRIC STRENGTH: **1500VAC / 1 MINUTE .**
- \* METHOD OF OPERATION : **AUTOMATIC INTERRUPTION AND AUTOMATIC RESETTING .**
- \* **IEC - 934** METHOD OF TRIPPING: "**TO**" = **THERMAL .**
- \* DEGREE OF TRIP - FREE BEHAVIOUR : "**CYCLING TRIP - FREE**"
- \* RESET TYPE: AUTO RESET .

## APPROVAL :

- U L** APPROVAL: **75°C - 145°C**  
**10A 125VAC 100,000 CYCLES**
- CSA** APPROVAL: **75°C - 145°C**  
**10A 125VAC 100,000 CYCLES**

## APPLICATIONS :

- \* TEMPERATURE CONTROLLER
- \* COFFEE MAKER
- \* DISH WASHER
- \* HOT PLATE