



**WINSTAR Display Co.,Ltd.**  
**華凌光電股份有限公司**



Winstar Display Co., LTD

華凌光電股份有限公司

WEB: <https://www.winstar.com.tw> E-mail: sales@winstar.com.tw



## SPECIFICATION

**CUSTOMER :** \_\_\_\_\_

**MODEL NO. :** WLOF00039000QGAAASA00

<p><b>APPROVED BY:</b> ( FOR CUSTOMER USE ONLY )</p>	
--	--

SALES BY	APPROVED BY	CHECKED BY	PREPARED BY
		Eason Chang Erick Chung	Kyra Chen

VERSION	DATE	REVISED PAGE NO.	SUMMARY
E	2022/04/15	9 15	Add PCBA Part number Add description of default selection

Precaution in use of TFT module: <https://www.winstar.com.tw/technology/download/declaration.html>

WINSTAR DISPLAY Co., Ltd.

MODLE NO :

<b>RECORDS OF REVISION</b>			<b>DOC. FIRST ISSUE</b>
<b>VERSION</b>	<b>DATE</b>	<b>REVISED PAGE NO.</b>	<b>SUMMARY</b>
0	2021/01/19		First issue
A	2021/02/09		Modify the Operating Temperature.
B	2021/04/19	22	Modify the Buzzer OD and add the new OD of Background, Backlight, Page
C	2021/04/29	22	Add OD 0x2104 of Mode info
D	2021/12/21	6 18	Modify the Summary content Add new object
E	2022/04/15	9 15	Add PCBA Part number Add description of default selection

# Contents

1. Smart Display Classification Information
2. Summary
3. Product information
4. Contour Drawing
5. Absolute Maximum Ratings
6. Electrical Characteristics
7. BOM
8. Block diagram
9. Interface
10. Reliability
11. Product inspection check list
12. Display Usage
13. Example Screen Layout (Industry application)
14. Example Screen Layout (Vehicle automotive)
15. Example Screen Layout (Medical application)
16. References

# 1. Smart Display Classification Information

W	L	0F	000390	00Q	G	A	AA	S	A	00
①	②	③	④	⑤	⑥	⑦	⑧	⑨	⑩	⑪

①	W: WINSTAR products										
②	Type: L:Standard K:Customization										
③	Display Type:	Standard:	<b>0H:</b> Character STN <b>0X:</b> Graphic STN (TAB/COF) <b>0F:</b> TFT <b>EH:</b> Character OLED <b>EX:</b> OLED (TAB/COF)				<b>0G:</b> Graphic STN <b>0P:</b> Graphic STN (COG) <b>EG:</b> Graphic OLED <b>EP:</b> OLED (COG)				
		Customization:	<b>DH:</b> Character <b>DN:</b> Graphic <b>ED:</b> OLED				<b>DG:</b> Graphic STN <b>OJ:</b> TFT				
④	Display size: (diagonal) / Display format: (resolution)	Character STN:	e.g., 8x1: 000801 16x2: 001602 24x4: 002404								
		Graphic STN:	e.g., 128x64: 012864 320x240: 320240								
		TFT Size (inch):	000096-0.96" / 000350-3.5" / 000430-4.3" / 000570-5.7" 000700-7.0" / 000800-8.0" / 001020-10.2" / 001210-12.1" (The last two digits are two digits after the decimal point)								
	OLED:	e.g., 128x64: 012864 Customization: 0001XX									
⑤	Serial No:	0A1 ~ 0ZZ	Customization STN: 000								
⑥	Touch Panel Type:	N: Without TP T: RTP G: CTP									
⑦	Model Interface:	A: CAN	H: HDMI			X: Combined					
		B: Bluetooth	R: Memory Specified			Y: Proprietary interface					
		C: Controller Specified	N: Ethernet								
		D: RS485	J: Analog I/O								
		E: RS232	K: USB								
		F: USART	L: WIFI								
		G: Logic I/O	M: Zigbee								
⑧	Interface Serial No.:	AA ~ ZZ									
⑨	Control Category:	S: Smart Display E: Entry N: Non-specified									
⑩	Special Code:	A → Generic B → Industrial C → Automotive D → Medical									
⑪	Model code:	00 ~ ZZ									

## **2. Summary**

### **3.9 Inch Smart Display Feature**

1. DC 5V working voltage, low power consumption for USB to drive.
2. Self testing after booting function.
3. CAN bus communication interface.
4. Support CANopen negotiation. Default baud rate is 250KB.
5. Built in flash memory, store the font and Object Dictionary Data.
6. Support capacitive touch panel (CTP).
7. Smart Display scenario is slave device display and action from Master Device instruction.
8. Embedded buzzer controlled by Master Device.
9. Demo set HOST can be used on multiple platforms, such as Computer (with USB to CAN Dongle), MCU, Raspberry Pi (with PiCAN2).

WINSTAR DISPLAY CO., Ltd.

# 3 Product information

## 3.1 Mechanical Data

Item	Standard Value	Unit
LCD panel	105.5(W) x 37.0(H) x 5.13	mm
PCB	157(W)*42(H)*1.6	mm
Housing outline	NA	mm

## 3.2 General information

Item	Standard Value	Unit
Operating voltage	5	Vdc
Communication Interface	CAN bus differential $\pm 3.3$	Vpp
MCU	STM32F750	N/A
Flash Memory	16	MB
SDRAM Frequency	108	MHz
LCD display size	3.9	inch
Dot Matrix	480x128 x RGB (TFT)	dot
Module dimension	105.5(W) x 37.0(H) x 5.13	mm
Active area	95.04 x 25.34	mm
Dot pitch	0.066(W)x 0.198(H)	mm
LCD type	TFT, Normally White, Transmissive	
View Direction	6 o'clock	
Aspect Ratio	Bar Type	
With /Without TP	With CTP	
Surface	Glare	



## **4. Contour Drawing**

WINSTAR DISPLAY Co., Ltd.

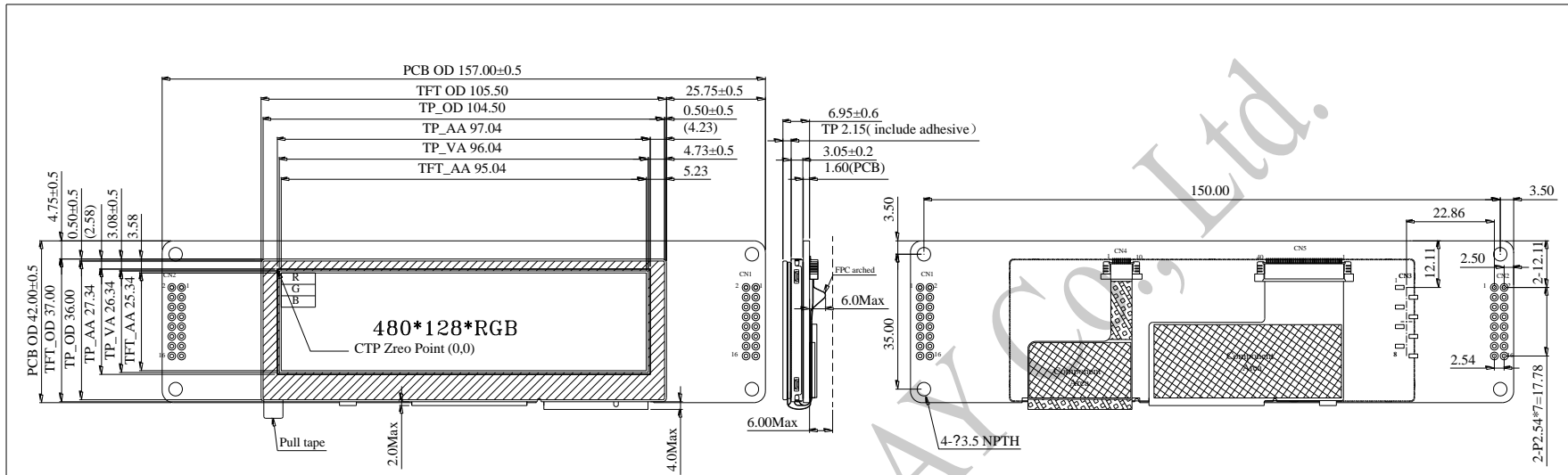

1	Lcd Type	TFT
2	View Direction	6 O'clock
3	Gray Scale Inversion Direction	12 O'clock
4	Screen size	3.9" (diagonal)
5	Surface	Glare
6	Display format	480x128xRGB
7	Operating Temperature	-10°C ~70°C
8	Storage Temperature	-30°C ~80°C
9	Active area	95.04(H)x25.34(V)mm
10	Dot pitch	0.198(H)x0.66(V)mm
11	Color arrangement	RGB-STRIPE
12	Brightness	300min. 400typ. cd/m2
13	CTP Driver IC	CYTM568 or equivalent
14	CTP Resolution	480*128

CN1		CN2		CN3	
PIN	SYMBOL	PIN	SYMBOL	PIN	SYMBOL
1	+5V	1	NC	1	NC
2	DGND	2	VDD3V	2	NC
3	GND	3	NC	3	NC
4	D-	4	TAG_SWCLK	4	NC
5	CAN High	5	NC	5	NC
6	D+	6	GND	6	NC
7	CAN Low	7	NC	7	NC
8	+5V	8	TAG_SWDI	8	NC
9	GND	9	NC		
10	NC	10	NRST		
11	GND	11	NC		
12	NC	12	TAG_SWDO		
13	NC	13	DGND		
14	NC	14	DGND		
15	NC	15	+5V		
16	NC	16	NC		

The non-specified tolerance of dimension is ±0.3 mm .

## 5. Absolute Maximum Ratings

Item	Symbol	Min	Typ	Max	Unit
Operating Temperature	TOP	-10	—	+70	°C
Storage Temperature	TST	-30	—	+80	°C

Note: Device is subject to be damaged permanently if stresses beyond those absolute maximum ratings listed above  
1. Temp.  $\leq 60^{\circ}\text{C}$ , 90% RH MAX. Temp.  $> 60^{\circ}\text{C}$ , Absolute humidity shall be less than 90% RH at  $60^{\circ}\text{C}$

## 6. Electrical Characteristics

Item	Symbol	Min	Typ	Max	Unit	Remark
Supply Voltage For Analog	VCC	4.75	5	5.25	V	
Interface Operation Voltage	ICC		350		mA	

## 7. BOM

Item	Description	Remark
LCM	WF39QTIBSDBG0# w/o PCBA	
PCBA	SV100039000QA00N0100	

# 8. Block diagram

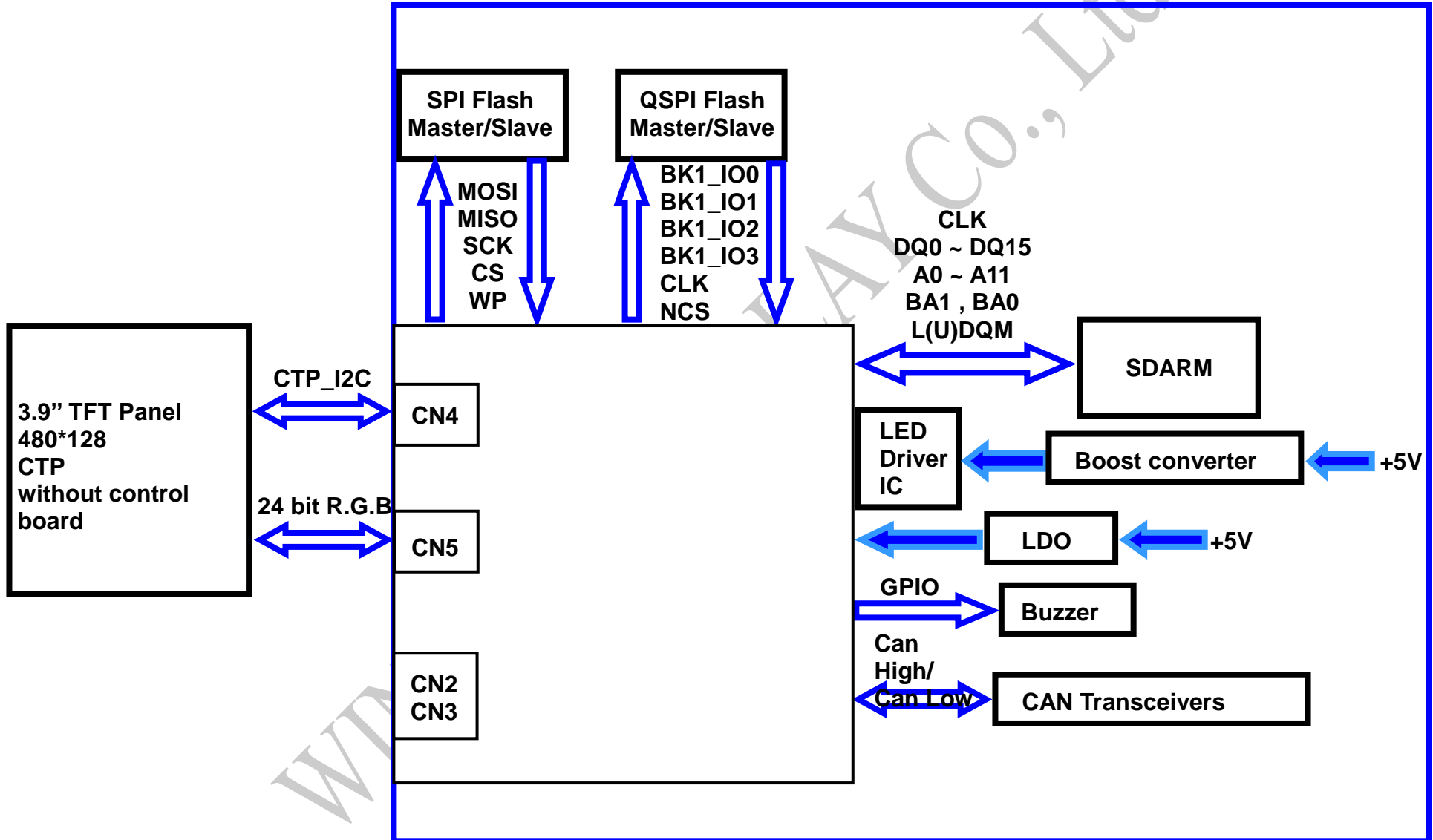

# 9. Interface

CN1 definition:

Pin	Symbol	Function	Remark
1	+5V	Power supply 5V input	Input
2	DGND	GND for USART interface	Output
3	GND	Power supply GND input	Input
4	D-	Differential signal D-	I/O
5	CAN High	CAN bus D+	I/O
6	D+	Differential signal D+	I/O
7	CAN Low	CAN bus D-	I/O
8	+5V	5V output for USART interface	Output
9	DGND	GND for USART interface	Output
10	NC		
11	DGND	GND for USART interface	Output
12	NC		
13	NC		
14	NC		
15	NC		
16	NC		

**CN2 definition:**

Pin	Symbol	Function	Remark
1	NC		
2	VMCU	Power supply 3V3 input	Input
3	NC		
4	TAG_SWCLK	JTAG Serial Wire Clock interface	Clock
5	NC		
6	GND	GND for USART interface	I/O
7	NC		
8	TAG_SWDIO	JTAG Serial Wire debug Data Input/Output interface	I/O
9	NC		
10	NRST	Reset input Connect this pin to the (active low) reset input of the target MCU.	I/O
11	NC		
12	TAG_SWO	JTAG Serial Wire trace Output - Optional interface	Output
13	DGND	GND for USART interface	I/O
14	DGND	GND for USART interface	I/O
15	+5V	Power supply 5V input	Input
16	NC		

**CN3 definition:**

Pin	Symbol	Function	Remark
1	NC		
2	NC		
3	NC		
4	NC		
5	NC		
6	NC		
7	NC		
8	NC		

# 10. Reliability

Content of Reliability Test (Wide temperature, -20°C~70°C)

Environmental Test			
Test Item	Content of Test	Test Condition	Note
High Temperature storage	Endurance test applying the high storage temperature for a long time.	80°C 96hrs	2
Low Temperature storage	Endurance test applying the low storage temperature for a long time.	-30°C 96hrs	1,2
High Temperature Operation	Endurance test applying the electric stress (Voltage & Current) and the thermal stress to the element for a long time.	70°C 96hrs	—
Low Temperature Operation	Endurance test applying the electric stress under low temperature for a long time.	-10°C 96hrs	1
High Temperature/ Humidity Operation	The module should be allowed to stand at 40°C,90%RH max	40°C,90%RH 96hrs	1,2
Thermal shock resistance	The sample should be allowed stand the following 10 cycles of operation <div style="text-align: center;"> <p style="margin: 0;">-20°C    25°C    70°C</p> <p style="margin: 0;">30min    5min    30min</p> <p style="margin: 0;">1 cycle</p> </div>	-10°C/70°C 10 cycles	—
Vibration test	Endurance test applying the vibration during transportation and using.	Total fixed amplitude : 1.5mm Vibration Frequency : 10~55Hz One cycle 60 seconds to 3 directions of X,Y,Z for Each 15 minutes	3
Static electricity test	Endurance test applying the electric stress to the terminal.	VS=±2KV~±6KV(contact),±2KV~±8KV(air), RS=330Ω CS=150pF 10 times	—

Note1: No dew condensation to be observed.

Note2: The function test shall be conducted after 4 hours storage at the normal Temperature and humidity after remove from the test chamber.

Note3: The packing have to including into the vibration testing.

# 11. Product inspection check list

Check samples by meter  $V_{IN}$ ,  $I_{system}$

Item	No 1	No 2	No 3	Note
$V_{IN}$ (V)	5	5	5	
$I_{System}$ (mA)	353	350	358	

Check sample Reliability Test

Item	Result	Note
Thermal shock	PASS_20200219	-10°C/70°C 20 cycles
High Temperature Operation	PASS_20200225	70°C 96hrs
Low Temperature Operation	PASS_20200302	-10°C 96hrs
Static electricity test	PASS_20200402	$V_S = \pm 2KV \sim \pm 6KV$ (contact), $\pm 2KV \sim \pm 8KV$ (air), $R_S = 330\Omega$ $C_S = 150pF$ 10 times
Vibration test	-	Total fixed amplitude : 1.5mm Vibration Frequency : 10~55Hz One cycle 60 seconds to 3 directions of X,Y,Z for Each 15 minutes

- Prepare sets for testing



# 12. Display Usage

## Functional description

Smart Display can be used to display the coordinate, status and data information provided by the connected HOST device. Customers can configure the position coordinates they want to display in normal operation mode (Node ID = 0x7B).

The Display is designed to be easily connected to a controller network, and to operate with minimum setup or knowledge of the SDO configuration on the controllers.

## Splash Screen

The default splash image is shown below.



- ✓ This product is produced as a generic product. If you require a custom splash image for your application, contact us to discuss.

## Default Selection

Press the preferred application and hold for 3 seconds for the first time power on.



## Acquisition of Displayed Data

The Smart Display can acquire the data that it displays by using the CANopen SDO protocol.

On Pre-operational mode, customers can set the coordinates of objects through SDO; On operational mode, customers can send data of objects through SDO, please see below.

Example:

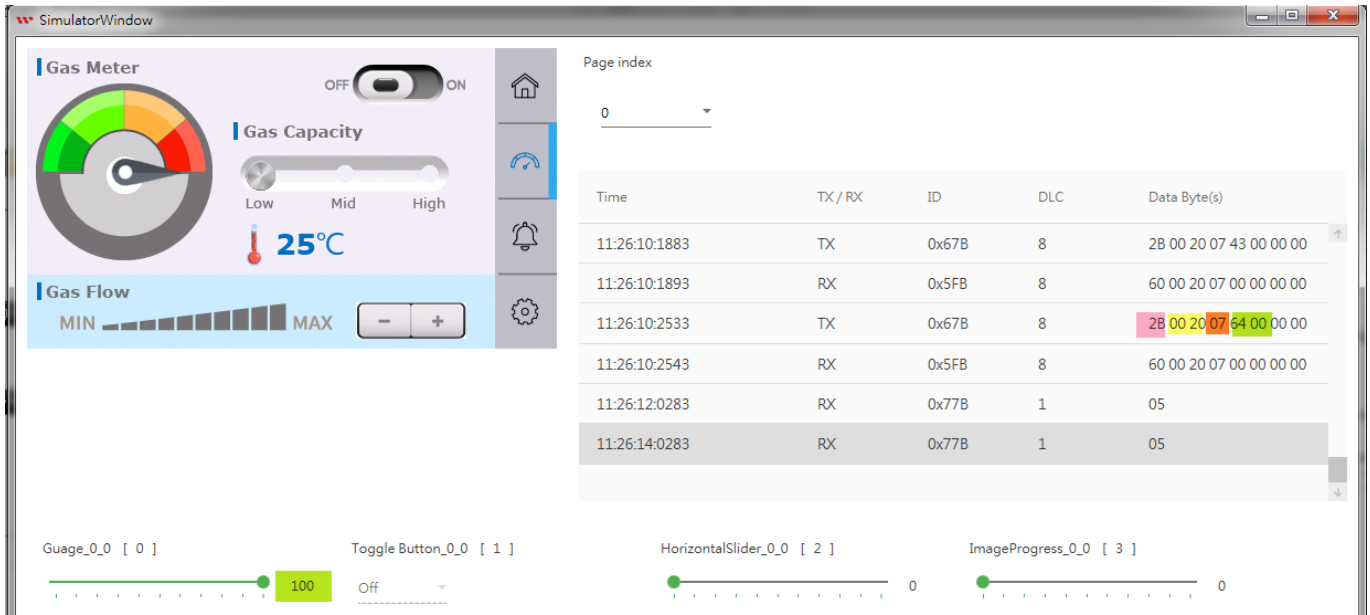

The client request :

Data length = 2 bytes

600 + Serv NodeId	0	2B	Index	Sub index	d1	d0	x	x
----------------------	---	----	-------	--------------	----	----	---	---

X : undefined. Put 0

To write the 2 byte data : 0x0064 in the object dictionary of node 7B at index 0x2000, sub-index 7, sends :

67B 2B 00 20 07 64 00 00 00

If success, the node 7B responds :

5FB 60 00 20 07 00 00 00 00

**Configuring the Display**

Winstar Smart Display CAN series offers an out-of-the-box CANopen development experience that will lower customers' development costs and speed time-to-market expectations.

The Smart Display can use wide-temperature are designed to support control applications in harsh operating conditions, which designed to be connected to a variety of different situation combinations, such as automotive, marine, power generation and oil-and-gas.

The Smart Display comes with standard UI objects to get customers project off the ground quickly. If customers need custom UI objects support, our engineers are here to help. Send over your contents in PNG/JPG format, we will send over a new set of UI objects within 3~5 working days.

The Smart Display is defined as a slave device, which is controlled by master device via CAN bus command to render display content on the display screen and return touch event data with protocol objects.

WINSTAR DISPLAY Co., Ltd.

### Node ID when Standalone

If the display is powered up standalone, the node id will default to 0x7B.

### Configuring the Main Screen

The screen on the display is 480 x 128 pixels.

The co-ordinate system used to specify the location of an item on the screen is shown in the diagram below. The coordinates are (x,y) where 'x' is the horizontal offset from the left, and 'y' is the vertical offset from the top.

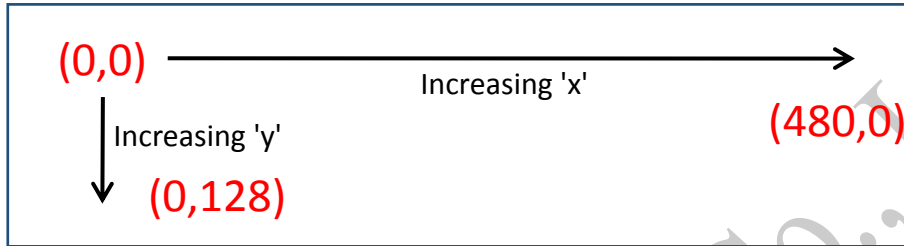

### Item Object Dictionary

There are 64 objects entries which are for configuration of the items that can be displayed on the screen in the latest F/W version. These are at location 0x2000 to 0x203F. Each object fully defines one screen item.









Each item has a set of sub-index items which are used to control the coordinate of the item. The exact functionality varies depending on the type of item selected. The template object is shown below:

#### Object List(0x2000 to 0x2009)

Object Index 0x2000 to 0x2009	Name	type	Description
Sub 0	Number of Entries	UNSIGNED8	9
Sub 1	Type	UNSIGNED8	style of Object
Sub 2	Reserve		
Sub 3	X position	INTEGER16	The object's X position
Sub 4	Y position	INTEGER16	The object's Y position
Sub 5	Number of Style	INTEGER16	The photo of style
Sub 6	Reserve		
Sub 7	Value 1	UNSIGNED16	Data to smart display from HOST
Sub 8	Value 2	UNSIGNED16	Data from smart display to HOST
Sub 9	Text	VISIBLE_STRING	Show strings (Unicode)max to 50 Character

### Sub 1 – Type

The item type is selected according to the table below:

Data	Description	Example Image
0	No Item This entry is not used	
1	Reserve	
2	Gauge	
3	Reserve	
4	Button	
5	Toggle Button	
6	Vertical Slider	
7	Horizontal Slider	
8	Reserve	
9	Reserve	
10	Battery	
11	Graph	
12	Indicator	

13	CircleProgress	
14	Reserve	
15	Reserve	
16	Reserve	
17	Number String	65535
18	Text String	ABC
19	Custom Widget	
20	Digitalclock	AM 10:08 2021/11/10
21	Reserve	
22	MultiState	

### Sub 3&4 – x and y position

Each item is drawn on screen by setting a draw rectangle. This rectangle is a bounding rectangle sized to fully enclose the item that is being drawn. The co-ordinates specify the position of the top left of this bounding rectangle.





### Sub 5 –Number of Style





Various types of icons





WINSTAR DISPLAY Co., Ltd.

Button	icon
0	
1	
2	
3	
4	

ToggleButton	icon
0	
1	
2	
3	
4	



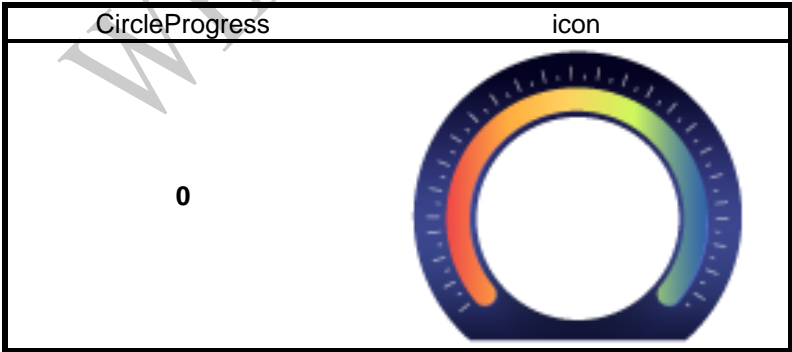
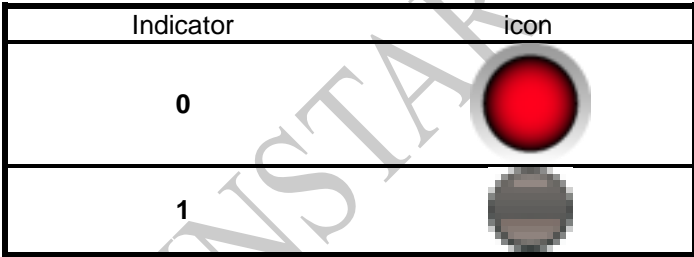
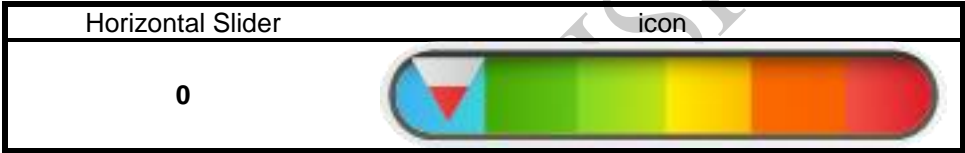
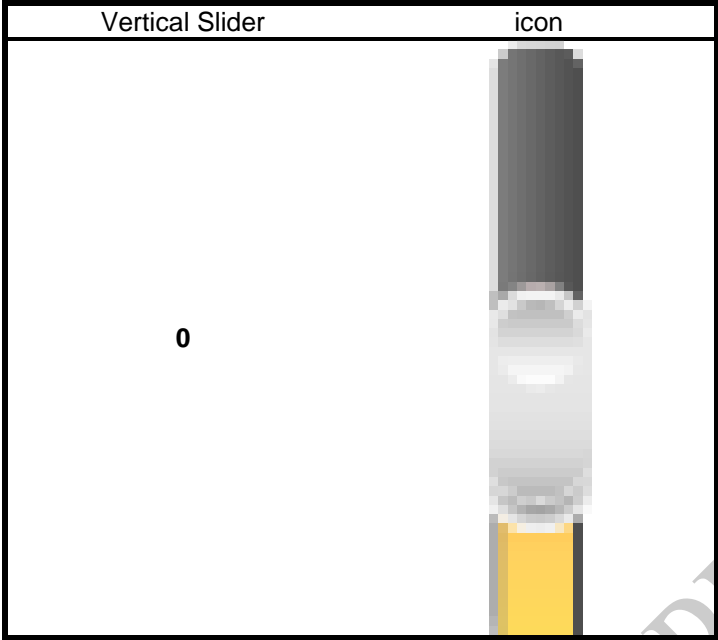
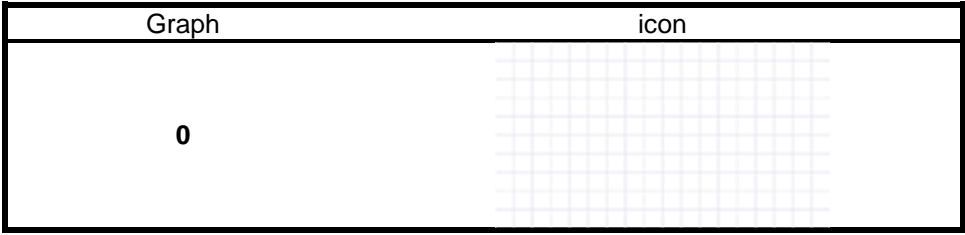

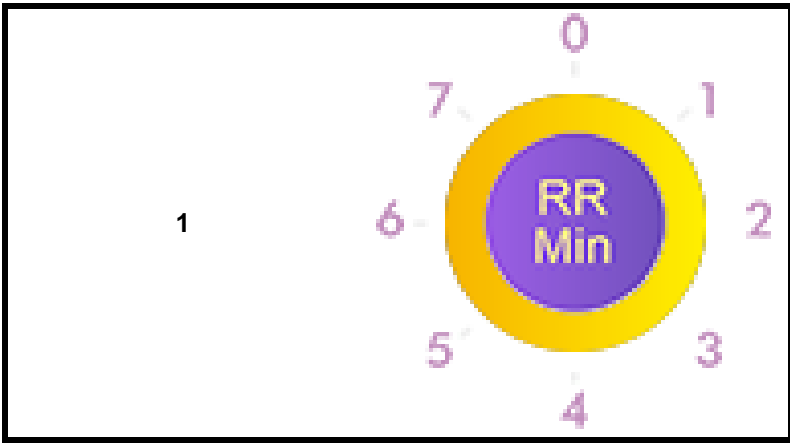



Custom Widget	icon
0	
1	
2	

Number String	icon
0	
1	
2	

Text String	icon
0	<b>ABC</b>
1	<b>ABC</b>
2	<b>ABC</b>

Digital Clock	icon
0	10:08
1	AM 10:08 2021/11/10

MultiState	icon
0	

Battery	icon
0	
1	
2	

### Sub 7&8 –Data send and receive

HOST sends numeric data to Sub 7 to control Smart Display objects another HOST receives numerical data from Sub8.

HOST can be used on multiple platforms, such as **Computer, MCU, Raspberry Pi(with PiCAN2)**.

### Background(0x2100)

Object Index 0x2100	Name	type	Description
Sub 0	Data	UNSIGNED8	Background of number

### Backlight(0x2101)

Object Index 0x2101	Name	type	Description
Sub 0	Data	UNSIGNED8	Value(0~100)

### Buzzer(0x2102)

Object Index 0x2102	Name	type	Description
Sub 0	Number of Entries	UNSIGNED8	
Sub 1	Cycle	UNSIGNED8	Number of repetitions
Sub 2	High	UNSIGNED8	High level
Sub 3	Low	UNSIGNED8	Low level
Sub 4	Active	BOOLEAN	Send reverse status to turn on the buzzer.  Ex: If the current active bit is true, send false bit and the buzzer is turned on.

### Page(0x2103)

Object Index 0x2103	Name	type	Description
Sub 0	Number of Entries	UNSIGNED8	
Sub 1	Count	UNSIGNED8	Return to page number
Sub 2	Index	UNSIGNED8	Jump to number page

### Mode(0x2104)

Object Index 0x2104	Name	type	Description
Sub 0	Number of Entries	UNSIGNED8	
Sub 1	Mode	UNSIGNED8	'0x00' enter pre-operation '0x01' enter operation

### 13. Example Screen Layout (Industry application)

#### Example Layout

The screen layout described in this section is intended to demonstrate the settings of screen items that can be used in an industry application situation.

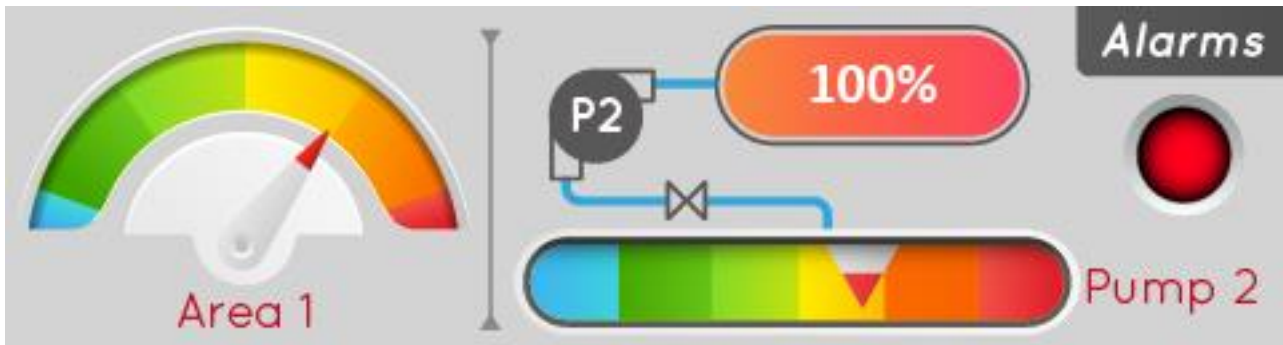

WINSTAR DISPLAY Co., Ltd.

## 14. Example Screen Layout (Vehicle automotive)

### Example Layout

The screen layout described in this section is intended to demonstrate the settings of screen items that can be used in a vehicle automotive situation.



WINSTAR DISPLAY Co., Ltd.

## 15. Example Screen Layout (Medical application)

### Example Layout

The screen layout described in this section is intended to demonstrate the settings of screen items that can be used in a Medical application situation.



## 16. References

[Sample code for Arduino Mega 2560](#)

WINSTAR DISPLAY CO., LTD.