



Ai-Thinker

ESP-C3-13-Kit Specification

Version V1.0

Copyright ©2021

Disclaimer and copyright notice

The information in this article, including the URL address for reference, is subject to change without prior notice.

The documentation is provided "as is" without any warranty, including any warranties of merchantability, fitness for a particular purpose, or non-infringement, and any warranties mentioned in the proposal, specification or sample. This document is not responsible for any infringement of any patent rights arising out of the use of the information in this document. No license, express or implied, by estoppel or otherwise, is hereby granted.

The test data obtained in this paper are all obtained by Ai-Thinker laboratory , and the actual results may be slightly different.

The Wi-Fi alliance membership mark is owned by the WiFi alliance.

All trade mark names, trademarks and registered trademarks mentioned herein are the property of their respective owners and are hereby declared.

The final interpretation right is owned by Shenzhen Ai-Thinker Technology Co., Ltd.

Note

The contents of this manual may be changed due to the version upgrade of the product or other reasons. Shenzhen Ai-Thinker Technology Co., Ltd. reserves the right to modify the contents of this manual without any notice. This manual is only used as a guide, and Shenzhen Ai-Thinker Technology Co., Ltd. makes every effort to provide accurate information in this manual, but Shenzhen Ai-Thinker Technology Co., Ltd. does not ensure that the contents of the manual are completely true,, All statements and information in this manual. and the recommendations do not constitute for any warranty, express or implied.

Document development/revision/revocation resume

Vision	Data	Revised content	Edition	Approve
V1.0	2021.05.10	First Edition	Yingying Chen	Hong Xu

CONTENT

1. Product Overview.....	5
1.1. Main parameters.....	7
2. Electrical parameters.....	8
2.1 Electrical characteristics.....	8
2.2 WIFI RF performance.....	8
2.3. BLE RF performance.....	9
3. Appearance dimensions.....	10
4. Pin definition.....	11
5. Schematic diagrams.....	13
6. Design guidance.....	14
6.1 Power supply.....	14
6.2 Antenna layout requirements.....	14
7. Reflow soldering curve.....	15
8. Packaging information.....	16
9. Contact us.....	16

1. Product Overview

ESP-C3-13-Kit is a core development board developed by Ai-Thinker based on ESP-C3-13 modules. The development board continues the classic design of the NodeMCU development board and leads to all I/Os on both sides. With pin headers, developers can connect peripherals according to their needs. When using the breadboard for development and debugging, the standard headers on both sides can make the operation easier and more convenient.

ESP-C3-13 is a Wi-Fi module developed by Ai-Thinker. This module core processor ESP32-C3 is a Wi-Fi+ BLE combination of system-level chips (SoC), designed for various applications such as internet of things (IoT), mobile devices, wearable electronics, smart home, etc.

ESP32-C3 with industry-leading low power and RF performance, supporting Wi-Fi IEEE802.11b/g/n agreements and BLE 5.0. ESP32-C3 chip is equipped with 32-bit RISC-V single-core processor, operating frequency up to 160 MHz. The chip is supported to have secondary development without using other microcontrollers or processors. The chip has a built-in 400 KB SRAM, 384 KB ROM, 8KB RTC SRAM. Also, the chip supports external Flash while it has built-in 4Mbit Flash. ESP32-C3 chip supports a variety of low-power consumption working states, which can meet the power consumption requirements of various application scenarios. The chip's unique features such as fine clock gating function, dynamic voltage clock frequency adjustment function, and RF output power adjustable function can achieve the best balance between communication distance, communication speed and power consumption.

ESP-C3-13 provides a wealth of peripheral interfaces, including UART, PWM, SPI, I2S, I2C, ADC, temperature sensor and there are 15 GPIOs.

ESP-C3-13 has a variety of unique hardware safety mechanisms. The hardware encryption accelerator supports AES, SHA and RSA algorithm. Among them, RNG, HMAC and Digital Signature modules provide more security features. Other security features include flash encryption and secure boot signature verification, etc. The perfect security mechanism enables the chip to be perfectly applied to various encryption products.

ESP-C3-13 module supports low-power Bluetooth: Bluetooth5, Bluetooth mesh.

Bluetooth rate support: 125Kbps, 500Kbps, 1Mbps, 2Mbps. Support broadcast extension, multi-broadcasting, channel selection.

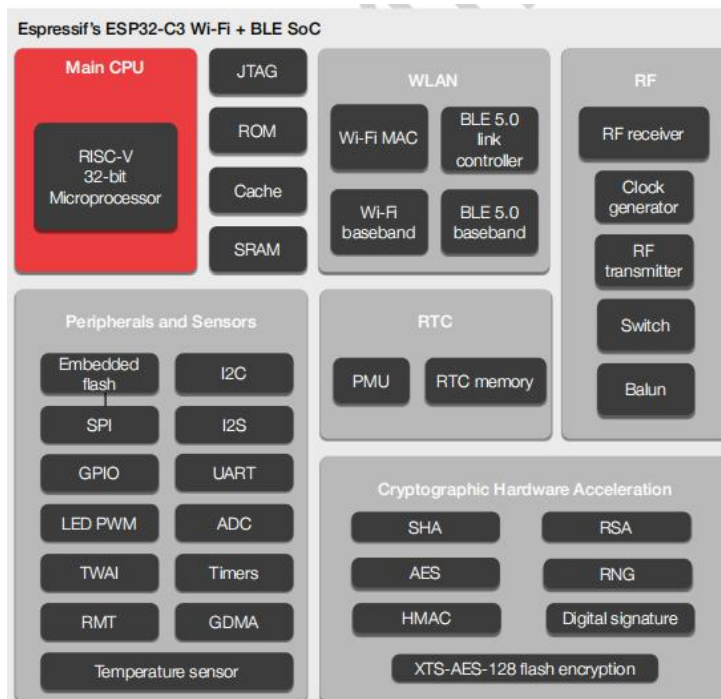

Characteristics

- Complete Wi-Fi 802.11b/g/n, 1T1R mode data rate up to 150Mbps
- Support BLE5.0, Classic Bluetooth is not supported, rate support: 125Kbps, 500Kbp, 1Mbps, 2Mbps
- 32-bit RISC-V single-core processor, supports a clock frequency of up to 160 MHz, with 400 KB SRAM, 384 KB ROM, 8KB RTC SRAM
- Support UART/PWM/GPIO/ADC/I2C/I2S interface, temperature sensor, pulse counter
- The development board has RGB three-in-one lamp beads, which is convenient for customers to develop
- Support multiple sleep modes, deep sleep electric current is less than 5uA
- UART rate up to 5Mbps 5Mbps
- Support STA/AP/STA+AP mode and mix mode.
- Support Smart Config (APP)/AirKiss (WeChat) of Android and IOS One-click network configuration
- Support UART port location upgrade and remote firmware upgrade (FOTA)
- General AT commands can be better understand
- Support secondary development, integrated Windows, Linux development environment
- ESP-C3-13 default adopt 4MByte Flash build-in chip, and does not support Flash expansion

1.1. Main parameters

Table 1 main parameter descriptions

Model Name	ESP-C3-13-Kit
Package	DIP-30
Size	20.0*18.0*3.1(±0.2)mm
Antenna	Compatible with on-board PCB antenna/IPEX
Frequency Range	2400 ~ 2483.5MHz
Operating Temperature	-40 °C ~ 85 °C
Store Temperature	-40 °C ~ 125 °C , < 90%RH
Power supply range	Supply voltage 5V, Supply current >500mA
Support Interface	UART/GPIO/ADC/PWM/I2C/I2S
IO	IO0,IO1,IO2,IO3,IO4,IO5,IO6,IO7,IO8,IO9,IO10,IO18,IO19, IO20,IO21
UART Rate	Support 110 ~ 4608000 bps, default 115200 bps
Bluetooth	BLE 5.0
Security	WEP/WPA-PSK/WPA2-PSK
SPI Flash	Default 4MByte, support 2MByte version
Wiring of onboard lights	IO5 connects to RGB blue lamp beads; IO3 connects to RGB red lamp beads; IO4 connects to RGB green lamp beads; IO19 connects to cool color lamp beads; IO18 connects to warm color lamp beads; (high level effective)

2. Electrical parameters

ESP-C3-13-Kit is development board is electrostatic sensitive devices and special precautions need to be taken when handling.



2.1 Electrical characteristics

Parameters		Conditions	Min	Typical values	Max	Unit
Supply voltage		VDD	3.0	3.3	5.0	V
I/O	V _{IL} /V _{IH}	-	-0.3/0.75VDD	-	0.25VDD/VDD+0.3	V
	V _{OL} /V _{OH}	-	N/0.8VIO	-	0.1VIO/N	V
	I _{MAX}	-	-	-	12	mA

2.2 WIFI RF performance

Description	Typical values	Unit
Operating frequency	2400 - 2483.5	MHz
Output power		
11n mode HT40, PA output power	15±2	dBm
11n mode HT20, PA output power	15±2	dBm
11g mode, PA output power	16±2	dBm
11b mode, PA output power	18±2	dBm
Receiving sensitivity		
CCK, 1 Mbps	-96±2	dBm
CCK, 11 Mbps	-88±2	dBm

6 Mbps (1/2 BPSK)	-92±2	dBm
54 Mbps (3/4 64-QAM)	-75±2	dBm
HT20 (MCS7)	-73±2	dBm
HT40 (MCS7)	-70±2	dBm

2.3. BLE RF performance

Description	Typical values	Unit
Output power		
Transmit power	0±2	dBm
Receiving sensitivity Low Energy consumption BLE: 1M		
Sensitivity@30.8%PER	-96±2	dBm

The following power consumption data are based on a 3.3 V power supply, 25°C ambient temperature and measured using an internal voltage regulator.

- All measurements were completed at the antenna interface without SAW filters
- All emission data are based on a duty cycle of 90%, measured in the mode of continuous emission.

Mode	Mix	Typical values	Max	Unit
Tx 802.11b, CCK 1Mbps, POUT=+20dBm	-	350	-	mA
Tx 802.11g, OFDM 54Mbps, POUT =+18dBm	-	290	-	mA
Tx 802.11n, MCS7, POUT =+17dBm	-	280	-	mA
Rx 802.11b, 1024 bit	-	90	-	mA
Rx 802.11g, 1024 bit	-	90	-	mA
Rx 802.11n, 1024 bit	-	93	-	mA
Modem-Sleep ^①	-	20	-	mA
Light-Sleep ^②	-	130	-	μA
Deep-Sleep ^③	-	5	-	μA
Power Off	-	1	-	μA

3. Appearance dimensions

ESP-C3-13-Kit development board four different package appearance diagrams

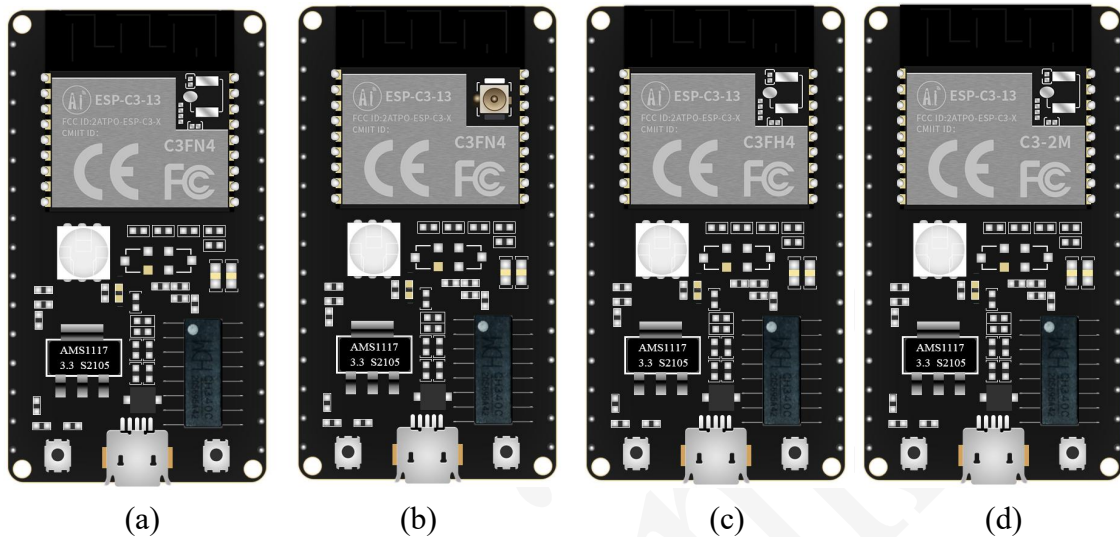

(The picture and silk screen are for reference only, the actual product shall prevail)

Different package selection instructions:

Figure (a) Type package (normal version): compatible with PCB on-board antenna and IPEX external antenna, built-in 4M flash;

Figure (b) Type package (normal version): Compatible with PCB on-board antenna and IPEX external antenna, built-in 4M flash;

Figure (c) Type package (high temperature version): compatible with PCB on-board antenna and IPEX external antenna, built-in 4M flash;

Figure (d) Type package: compatible with PCB on-board antenna and IPEX external antenna, external 2M flash;

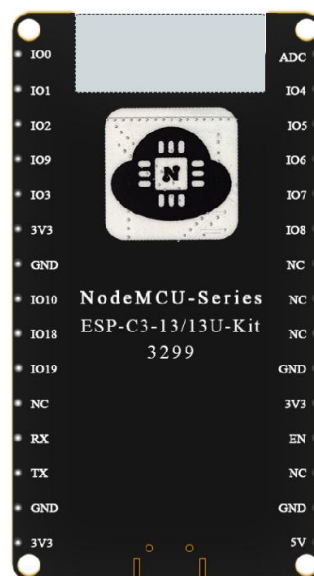

(The picture and silk screen are for reference only, the actual product shall prevail)

4. Pin definition

ESP-C3-13-Kit development board module is connected to 30 interfaces, refer to pin diagram, pin function definition table is interface definition.

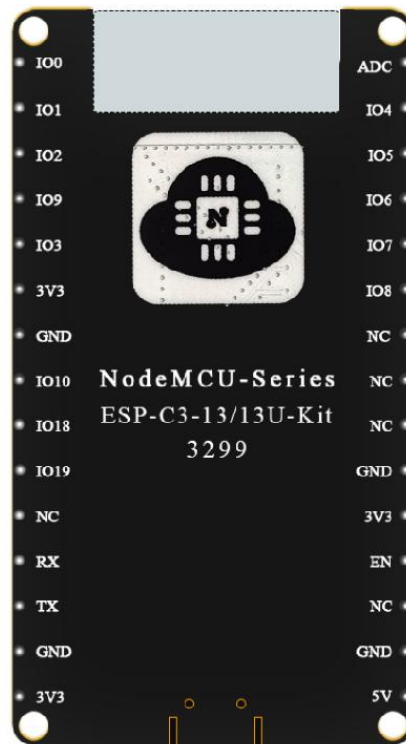

ESP-C3-13-Kit Diagram of Pin

Pin function definition

No.	Name	Function
1	ADC	ADC_CHECK(ADC1_CH0)
2	IO4	IO04 / ADC1_CH4 / FSPIHD / MTMS
3	IO5	IO05 / ADC2_CH0 / FSPIWP / MTDI
4	IO6	IO6 / FSPICLK / MTCK
5	IO7	IO7 / FSPID / MTDO
6	IO8	IO8
7	NC	NC
8	NC	NC
9	NC	NC

10	GND	GND
11	3V3	Digital 3.3V power output
12	EN	High level: chip enabled; Low level: chip shutdown; Pay attention not to leave the CHIP_PU pin floating;
13	NC	NC
14	GND	GND
15	5V	5V power input
16	3V3	Digital 3.3V power output
17	GND	GND
18	TX	TX0 / IO21
19	RX	RX0 / IO20
20	NC	NC
21	IO19	IO19
22	IO18	IO18
23	IO10	IO10 / FSPICSO
24	GND	GND
25	3V3	Digital 3.3V power output
26	IO3	IO03 / ADC1_CH3
27	IO9	IO9
28	IO2	IO2 / ADC1_CH2 / FSPIQ
29	IO1	IO1 / ADC1_CH1 / XTAL_32K_N
30	IO0	IO0 / ADC1_CH0 / XTAL_32K_N

5. Schematic diagrams

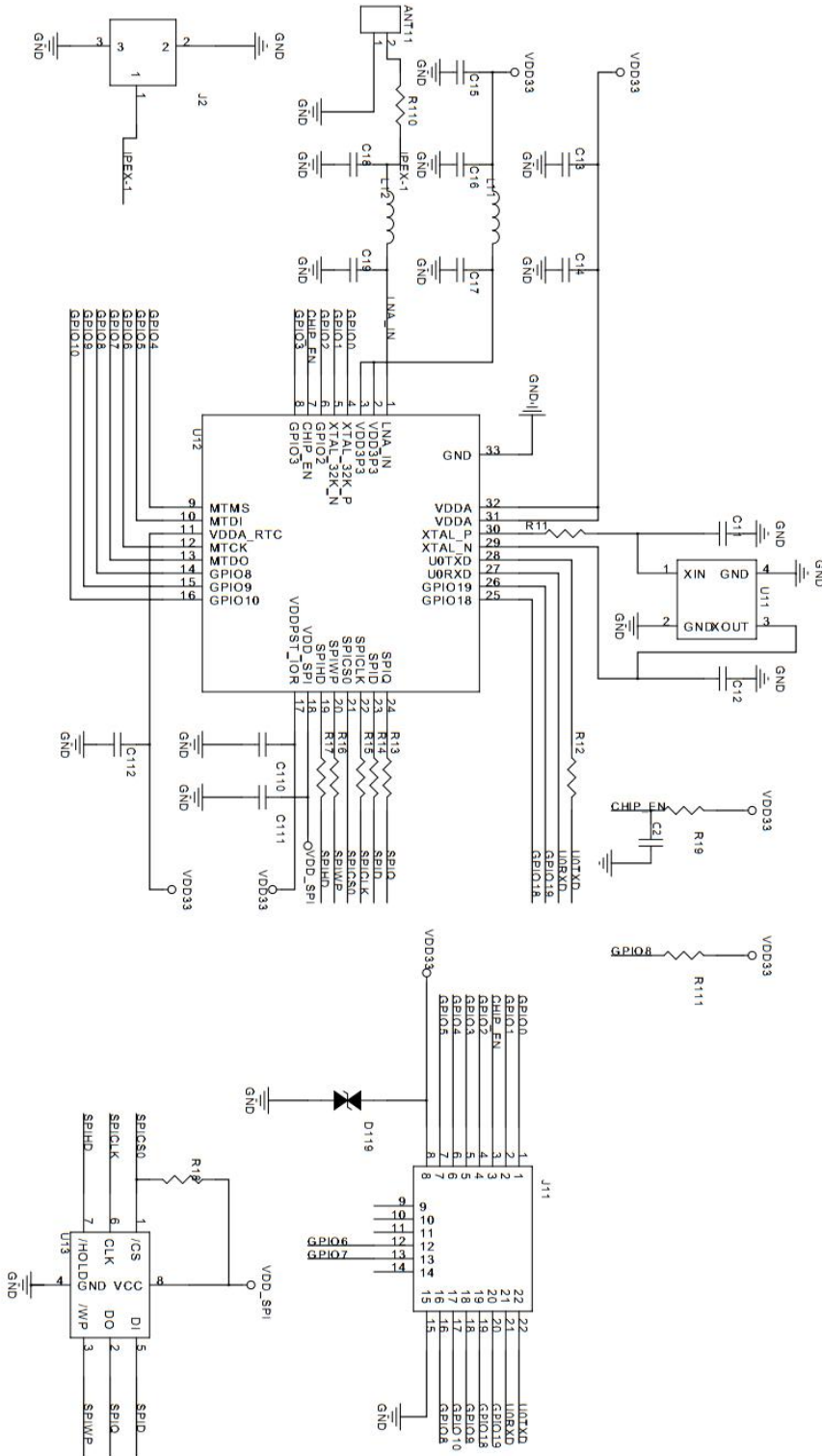

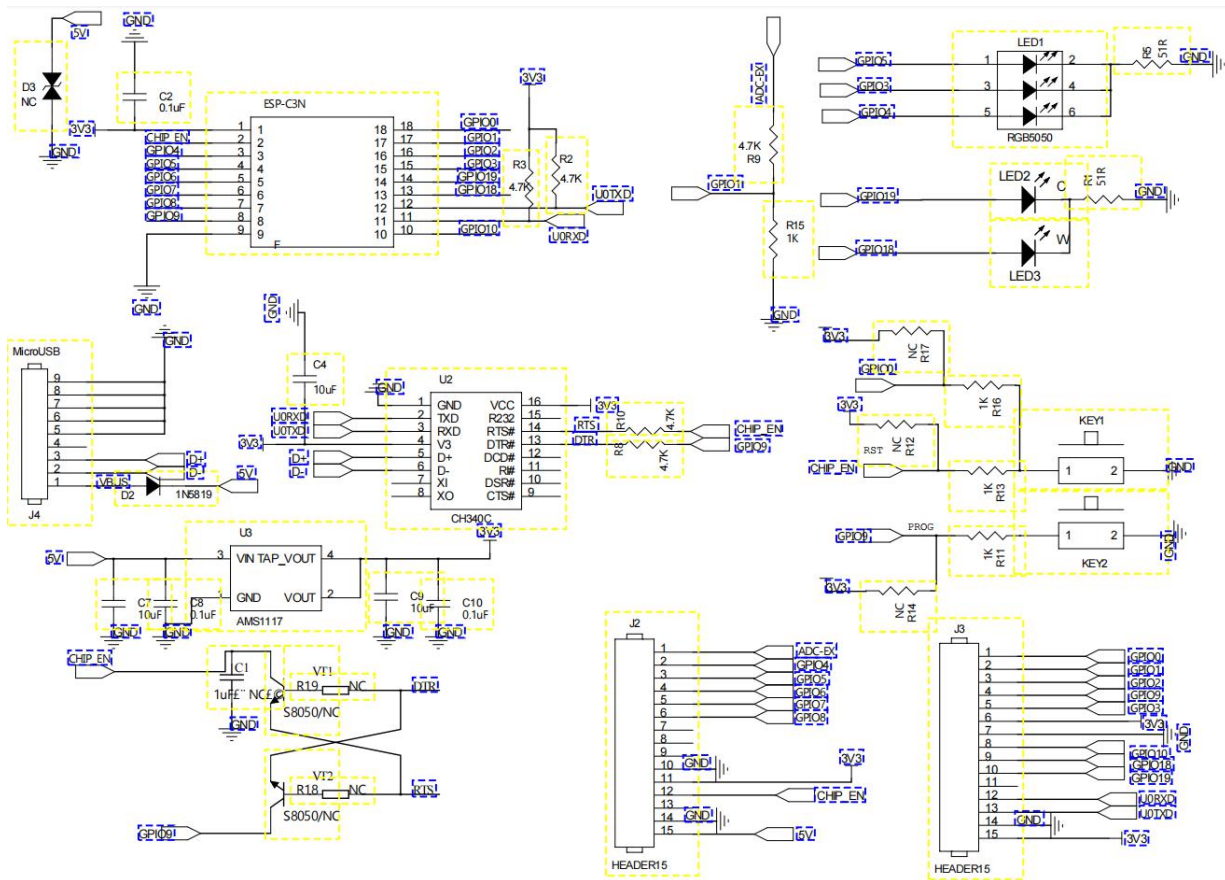

6. Design guidance

6.1 Power supply

- Recommend 5V voltage, peak current above 500m.
- It is recommended to use LDO for power supply; if DC-DC is used, the ripple is recommended to be controlled within 30mV.
- DC-DC the power supply circuit, it is suggested to reserve the position of output ripple can be optimized when the load changes greatly.
- It is recommended to add ESD devices to the 5V power interface.

6.2 Antenna layout requirements

It is forbidden to place metal parts around the module antenna, away from high-frequency components.

7. Reflow soldering curve

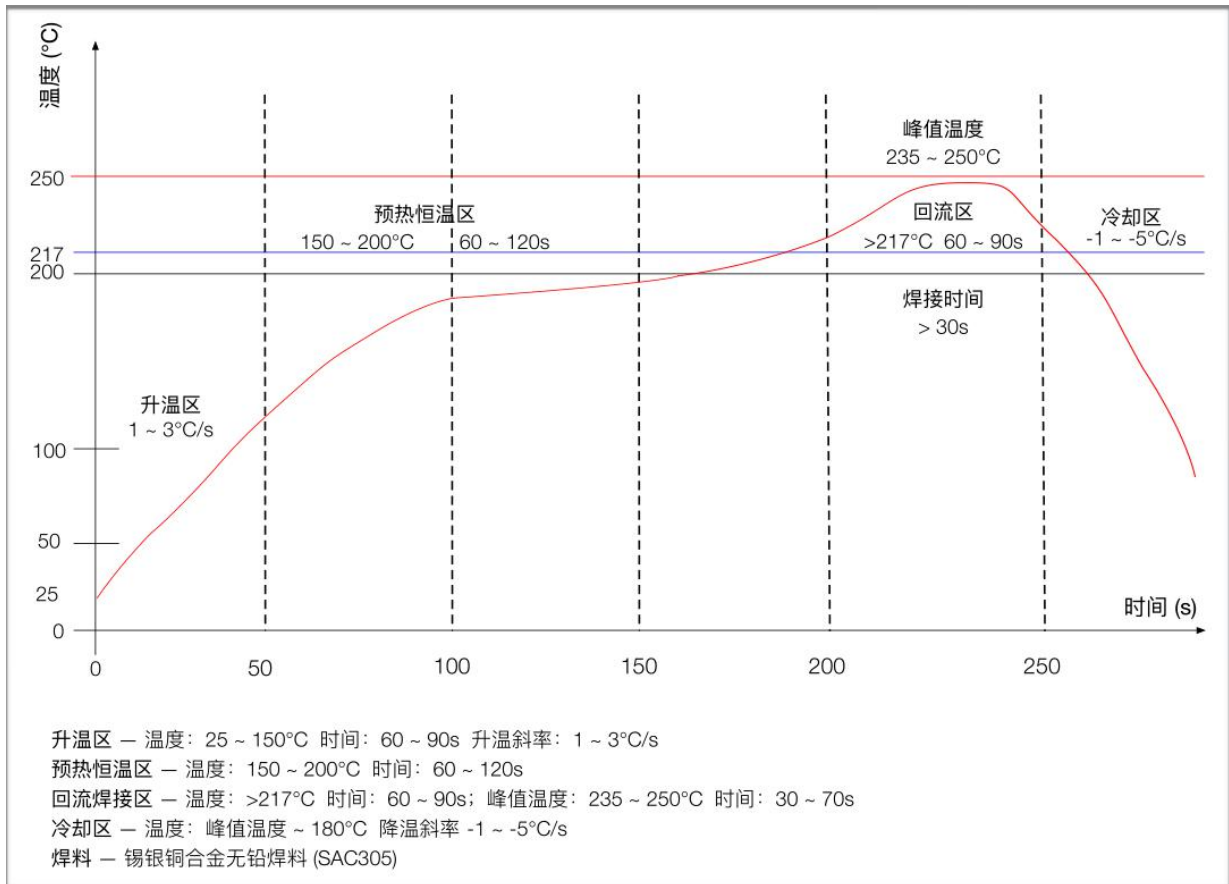

8. Packaging information

ESP-C3-13-Kit development board is an electrostatic bag with pearl cotton inserted.

9. Contact us

Website: <https://www.ai-thinker.com>

Development DOCS: <https://docs.ai-thinker.com>

Forum: <http://bbs.ai-thinker.com>

Order online: <https://ai-thinker.en.alibaba.com>

Business: overseas@aithinker.com

Support: support@aithinker.com

Add: Room 403, 408-410, Building C, Huafeng Smart Innovation Port, Gushu, Xixiang, Baoan District,
Shenzhen

Tel: 0755-29162996

