



Ai-Thinker

ESP-C3-32S-Kit Specification

Version V1.0

Copyright ©2021

Disclaimer and copyright notice

The information in this article, including the URL address for reference, is subject to change without notice.

The document is provided “as is” without any guarantee responsibility, including any guarantee for merchantability, suitability for a specific purpose, or non-infringement, and any guarantee mentioned elsewhere in any proposal, specification or sample. This document does not take any responsibility, including the responsibility for infringement of any patent rights caused by the use of the information in this document. This document does not grant any license for the use of intellectual property rights in estoppel or other ways, whether express or implied.

The test data obtained in the article are all obtained from Ai-Thinker’s laboratory test, and the actual results may vary slightly.

The Wi-Fi Alliance member logo is owned by the Wi-Fi Alliance.

All brand names, trademarks and registered trademarks mentioned in this article are the property of their respective owners, and it is hereby declared.

The final interpretation right belongs to Shenzhen Ai-Thinker Technology Co., Ltd.

Note

Due to product version upgrades or other reasons, the contents of this manual may be changed. Shenzhen Ai-Thinker Technology Co., Ltd. reserves the right to modify the contents of this manual without any notice or prompt. This manual is only used as a guide. Shenzhen Ai-Thinker Technology Co., Ltd. makes every effort to provide accurate information in this manual. However, Shenzhen Ai-Thinker Technology Co., Ltd. does not guarantee that the contents of the manual are completely free of errors. All statements and information in this manual And the suggestion does not constitute any express or implied guarantee.

CONTENT

1. Product overview.....	5
1.1 Features.....	6
1.2 Main parameters.....	7
2. Electrical parameters.....	8
2.1 Electrical characteristics.....	8
2.2 WIFI RF parameters.....	8
2.3 BLE RF performance.....	9
2.4 Power consumption.....	9
3. Exterior.....	10
4. Pin definition.....	11
5. Schematic diagram.....	14
6. Design guide.....	14
6.1 Power supply.....	14
6.2 Antenna layout requirements.....	14
7. Reflow soldering curve.....	15
8. Package.....	16
9. Contact us.....	16

1. Product overview

The ESP-C3-32S-Kit development board is a core development board designed by ESP-C3-32S modules. The development board continues the classic design of the NodeMCU development board, leading to all I/Os on both sides. With pin headers, developers can connect peripherals according to their needs. When using the breadboard for development and debugging, the standard headers on both sides can make the operation easier and more convenient.

The ESP32-C3 chip has industry-leading low-power performance and radio frequency performance, and supports Wi-Fi IEEE802.11b/g/n protocol and BLE 5.0. The chip is equipped with a RISC-V 32-bit single-core processor with an operating frequency of up to 160 MHz. Support secondary development without using other microcontrollers or processors. The chip has built-in 400 KB SRAM, 384 KB ROM, 8KB RTC SRAM, built-in 4MB Flash also supports external Flash. The chip supports a variety of low power consumption working states, which can meet the power consumption requirements of various application scenarios. The chip's unique features such as fine clock gating function, dynamic voltage clock frequency adjustment function, and RF output power adjustable function can achieve the best balance between communication distance, communication rate and power consumption.

The ESP-C3-32S module provides a wealth of peripheral interfaces, including UART, PWM, SPI, I2S, I2C, ADC, temperature sensor and up to 21 available GPIOs.

The ESP-C3-32S module has a variety of unique hardware security mechanisms. The hardware encryption accelerator supports AES, SHA and RSA algorithms. Among them, RNG, HMAC and digital signature (Digital Signature) modules provide more security features. Other security features include flash encryption and secure boot (se-cure boot) signature verification. The perfect security mechanism enables the chip to be perfectly applied to various encryption products.

The ESP-C3-32S module supports low-power Bluetooth: Bluetooth5, Bluetooth mesh. Bluetooth rate support: 125Kbps, 500Kbps, 1Mbps, 2Mbps. Support broadcast extension, multi-broadcasting, channel selection.

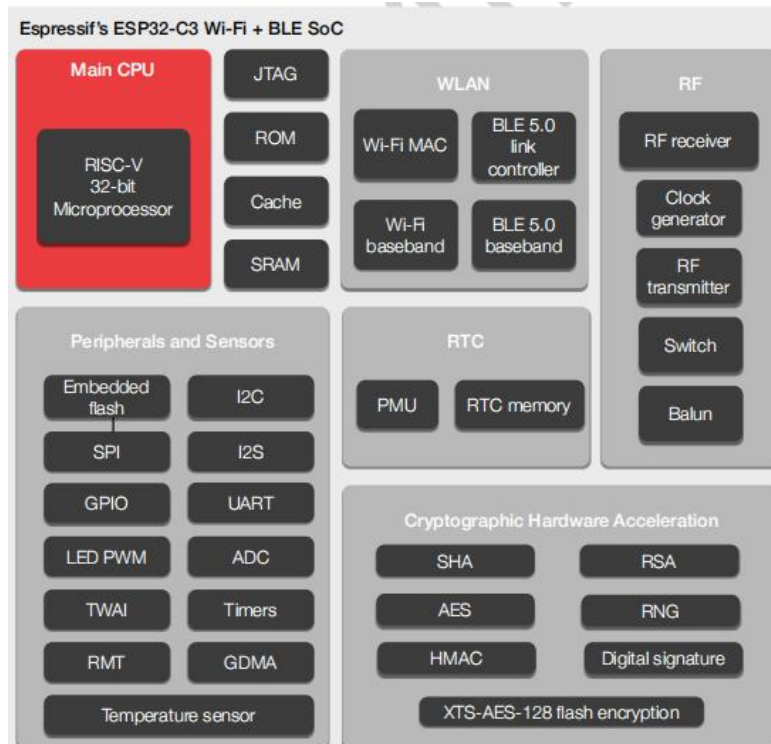

1.1 Features

- Complete 802.11b/g/n Wi-Fi+BT+BLE SoC module, 1T1R mode data rate up to 150Mbps
- Built-in ESP32-C3 chip, RISC-V 32-bit single-core processor, support clock frequency up to 160 MHz, with 400 KB SRAM, 384 KB ROM, 8KB RTC SRAM
- Support UART/GPIO/ADC/PWM/I2C/I2S interface, temperature sensor, pulse counter
- The development board has RGB three-in-one lamp beads, which is convenient for the second development of customers
- Integrated Wi-Fi MAC/BB/RF/PA/LNA/Bluetooth
- Support BLE5.0, does not support classic Bluetooth
- Support multiple sleep modes, deep sleep current is less than 5uA
- Serial port rate up to 5Mbps
- Support STA/AP/STA+AP mode and promiscuous mode
- Support Smart Config (APP)/AirKiss (WeChat) of Android and IOS, one-click network configuration
- Support serial port local upgrade and remote firmware upgrade (FOTA)
- General AT commands can be used quickly

- Support secondary development, integrated Windows and Linux development environment
- About Flash: ESP-C3-32S uses the built-in 4MByte Flash of the chip by default, and supports the external Flash version of the chip.

1.2 Main parameters

List 1 main parameters description

Model	ESP-C3-32S-Kit
Packaging	DIP-30
Size	25.5*18.0*3.1(±0.2)MM
Antenna	PCB antenna/IPEX port
Spectrum range	2400 ~ 2483.5MHz
Working temperature	-40 °C ~ 85 °C
Storage temperature	-40 °C ~ 125 °C , < 90%RH
Power supply	Power supply voltage 5V, power supply current >500mA
Interface	UART/GPIO/ADC/PWM/I2C/I2S
IO port	IO0,IO1,IO2,IO3,IO4,IO5,IO6,IO7,IO8,IO9,IO10,IO12,IO14,IO15, IO16,IO17,IO18,IO19,IO20,IO21
Serial port rate	Support 110 ~ 4608000 bps , default 115200 bps
Bluetooth	BLE 5.0
Safety	WEP/WPA-PSK/WPA2-PSK
SPI Flash	The default configuration is 4MByte, support 2MByte version
Wiring of onboard lights	IO5 is connected to RGB blue lamp beads; IO3 is connected to RGB red lamp beads; IO4 is connected to RGB green lamp beads; IO19 is connected to cool color lamp beads; IO18 is connected to warm color lamp beads; (high level is valid)

2. Electrical parameters

The ESP-C3-32S-Kit development board is an electrostatic sensitive device, and special precautions need to be taken when handling it



2.1 Electrical characteristics

Parameters		Condition	Min	Typical	Max	Unit
Voltage		VDD	3.0	3.3	5.0	V
I/O	V_{IL}/V_{IH}	-	-0.3/0.75VDD	-	0.25VDD/VDD+0.3	V
	V_{OL}/V_{OH}	-	N/0.8VIO	-	0.1VIO/N	V
	I_{MAX}	-	-	-	12	mA

2.2 WIFI RF parameters

Description	Typical	Unit
Working frequency	2400 - 2483.5	MHz
Output Power		
11n mode HT40, PA output power is	15±2	dBm
11n mode HT20, PA output power is	15±2	dBm
In 11g mode, the PA output power is	16±2	dBm
In 11b mode, PA output power	18±2	dBm
Receiving sensitivity		
CCK, 1 Mbps	-96±2	dBm
CCK, 11 Mbps	-88±2	dBm

6 Mbps (1/2 BPSK)	-92±2	dBm
54 Mbps (3/4 64-QAM)	-75±2	dBm
HT20 (MCS7)	-73±2	dBm
HT40 (MCS7)	-70±2	dBm

2.3 BLE RF performance

Description	Typical	Unit
Output power		
Transmit power	0±2	dBm
Receiving sensitivity Bluetooth low energy 1M		
Sensitivity@30.8%PER	-96±2	dBm

2.4 Power consumption

The following power consumption data is based on a 3.3V power supply, an ambient temperature of 25°C, and measured using an internal voltage regulator.

- All measurements are done at the antenna interface without SAW filter.
- All emission data is based on 90% duty cycle, measured in continuous emission mode

Mode	Min	Typical	Max	Unit
Transmit 802.11b, CCK 1Mbps, POUT=+20dBm	-	350	-	mA
Transmit 802.11g, OFDM 54Mbps, POUT =+18dBm	-	290	-	mA
Transmit 802.11n, MCS7, POUT =+17dBm	-	280	-	mA
Receive 802.11b, the packet length is 1024 bytes	-	90	-	mA

Receive 802.11g, the packet length is 1024 bytes	-	90	-	mA
Receive 802.11n, the packet length is 1024 bytes	-	93	-	mA
Modem-Sleep ^①	-	20	-	mA
Light-Sleep ^②	-	130	-	μA
Deep-Sleep ^③	-	5	-	μA
Power Off	-	1	-	μA

3. Exterior

The appearance of four different packages of ESP-C3-32S-Kit development board

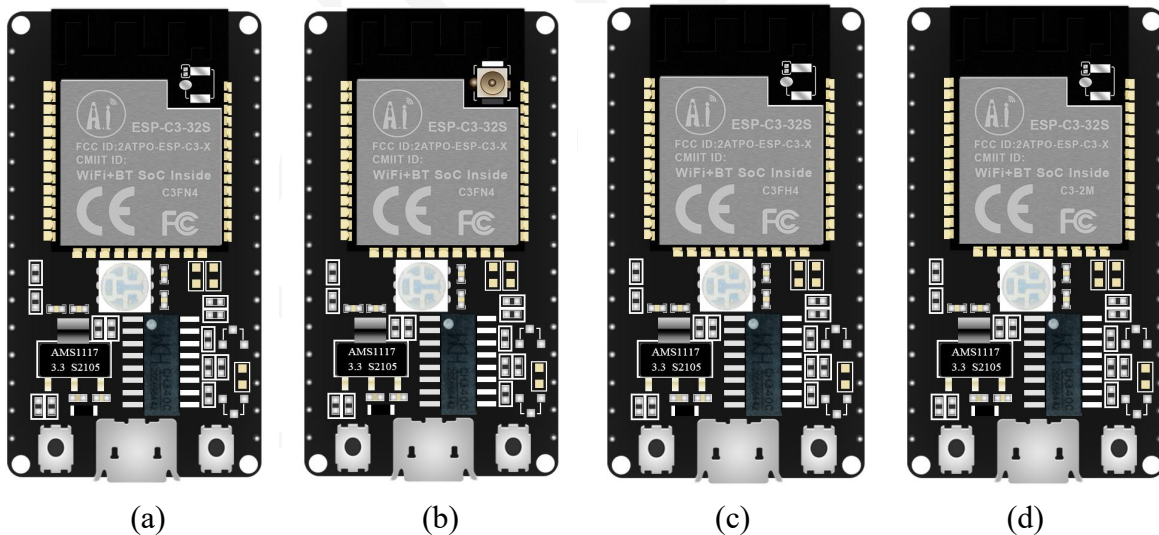

(The picture and silk screen are for reference only, the actual product shall prevail)

Different package selection description:

Figure (a) Type package (normal version): Compatible with PCB onboard antenna and IPEX external antenna, built-in 4M flash;

Figure (b) Type package (normal version): Compatible with PCB onboard antenna and IPEX external antenna, built-in 4M flash;

Figure (c) Type package (high temperature version): Compatible with PCB onboard antenna and IPEX external antenna, built-in 4M flash;

Figure (d) Type package: compatible with PCB onboard antenna and IPEX external antenna, external 2M flash;



(The picture and silk screen are for reference only, the actual product shall prevail)

4. Pin definition

The ESP-C3-32S-Kit development board module has a total of 30 interfaces, as shown in the pin diagram, the pin function definition table is the interface definition table



ESP-C3-32S-Kit pin diagram

Pin function definition table

No.	Name	Function description
1	ADC	ADC_CHECK(ADC1_CH0)
2	IO1	IO1 / ADC1_CH1 / XTAL_32K_N
3	IO2	IO2 / ADC1_CH2 / FSPIQ
4	IO3	IO03 / ADC1_CH3
5	IO4	IO04 / ADC1_CH4 / FSPIHD / MTMS
6	IO5	IO05 / ADC2_CH0 / FSPIWP / MTDI
7	IO6	IO6 / FSPICLK / MTCK
8	IO7	IO7 / FSPID / MTDO
9	IO8	IO8
10	GND	GND
11	3V3	Digital 3.3V power output
12	EN	High level: chip enable; Low level: the chip is turned off; Note that the EN pin should not be left floating;
13	IO0	IO0 / ADC1_CH0 / XTAL_32K_N
14	GND	GND
15	5V	5V power input
16	3V3	Digital 3.3V power output
17	GND	GND
18	U0RX	RX0 / IO20
19	U0TX	TX0 / IO21
20	SPICS0	SPICS0 / IO14
21	SPICLK	SPICLK / IO15
22	SPIQ	SPIQ / IO17
23	SPID	SPID / IO16
24	GND	GND

25	3V3	Digital 3.3V power output
26	IO10	IO10 / FSPICSO
27	IO9	IO9
28	SPIHD	SPIHD / IO12
29	IO18	IO18
30	IO19	IO19

5. Schematic diagram

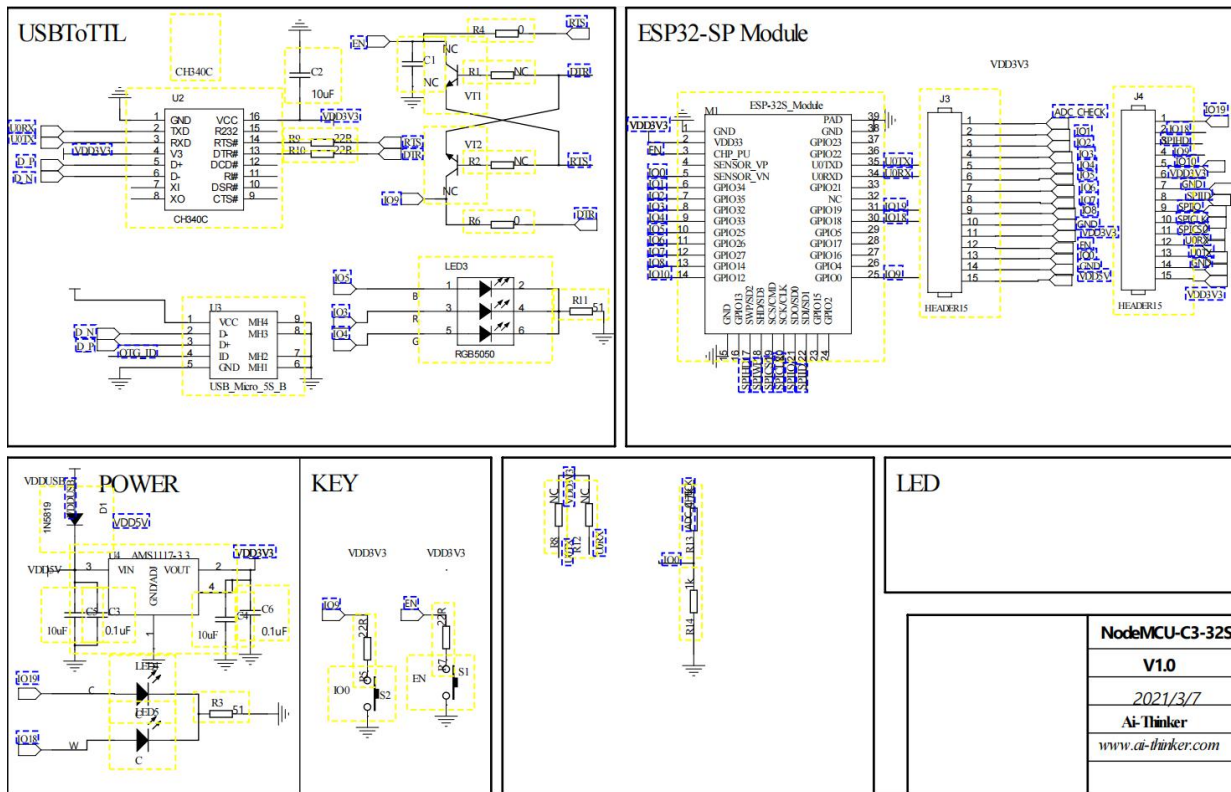

6. Design guide

6.1 Power supply

- Recommended 5V voltage, peak current above 500mA
- It is recommended to use LDO for power supply; if using DC-DC, it is recommended that the ripple be controlled within 30mV
- It is recommended to reserve the position of the dynamic response capacitor for the DC-DC power supply circuit, which can optimize the output ripple when the load changes greatly.
- It is recommended to add ESD devices to the 5V power interface

6.2 Antenna layout requirements

It is forbidden to place metal parts around the module antenna, away from high-frequency components.

7. Reflow soldering curve

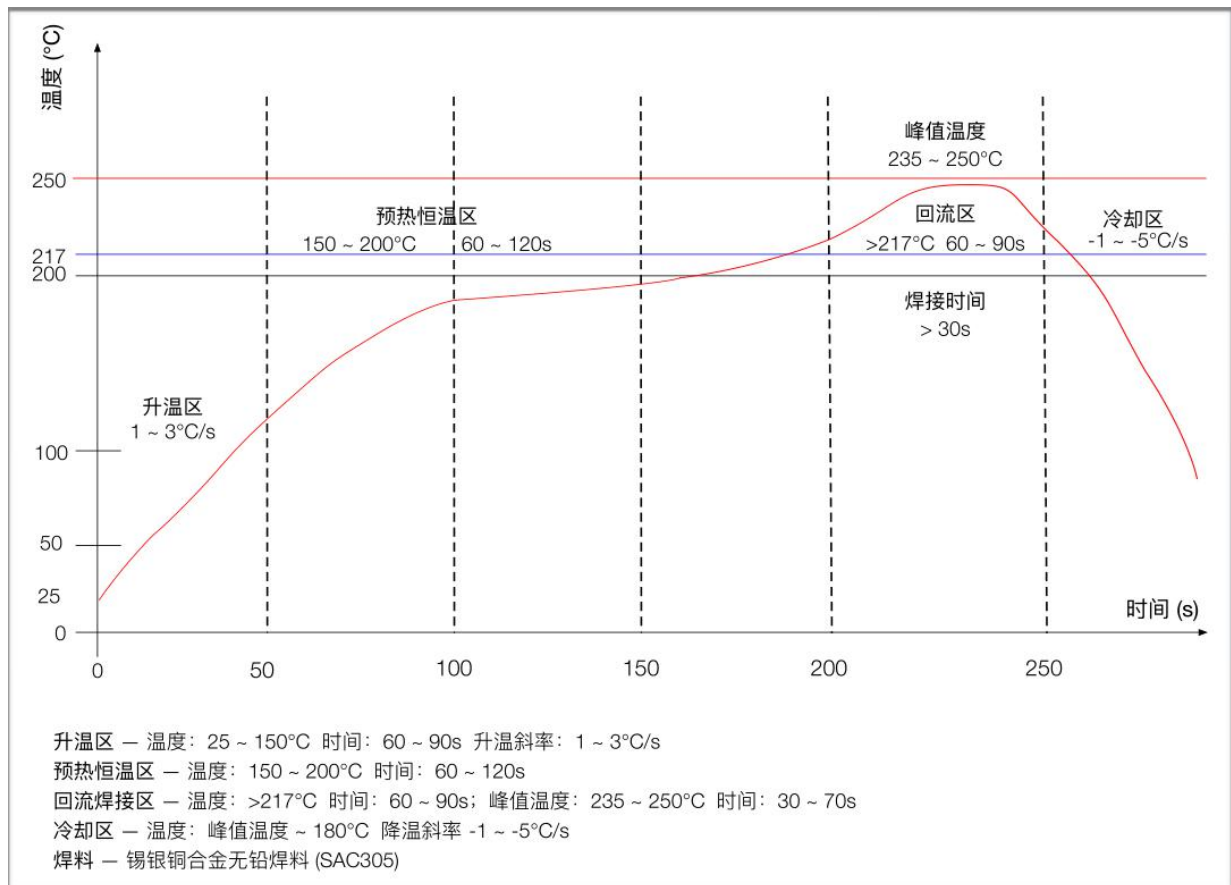

8. Package

The packaging of the ESP-C3-32S-Kit development board is an electrostatic bag with pearl cotton inserted.

9. Contact us

Website: <https://www.ai-thinker.com>

Development DOCS: <https://docs.ai-thinker.com>

Forum: <http://bbs.ai-thinker.com>

Order online: <https://ai-thinker.en.alibaba.com>

Business: overseas@aithinker.com

Support: support@aithinker.com

Add: Room 403, 408-410, Building C, Huafeng Smart Innovation Port, Gushu, Xixiang, Baoan District, Shenzhen

Tel: 0755-29162996

