

### ● FEATURES

- EXCELLENT CLOCK SIGNAL GENERATOR FOR CPU'S
- WIDE FREQUENCY RANGE
- INDUSTRY STANDARD PACKAGES

### SERIES A, B, C

**HC-49/U, HC-51/U, AND UM-1**

### ● SPECIFICATIONS

FREQUENCY RANGE		100.00 KHZ TO 300.00 MHZ
HOLDER TYPES	A: HC-49/U	1.00 MHZ TO 300.00 MHZ
	B: HC-51/U	100.00 KHZ TO 4.00 MHZ
	C: UM-1	8.00 MHZ TO 300.00 MHZ
FREQUENCY TOLERANCE AT 25 °C		±30 PPM TYPICAL ±50 PPM MAXIMUM
FREQUENCY STABILITY OVER TEMPERATURE		±50 PPM TYPICAL ±100 PPM MAXIMUM
OPERATING TEMPERATURE RANGE		-20 °C TO +70 °C STANDARD
		-40° C TO +85 °C EXTENDED
STORAGE TEMPERATURE RANGE		-55 °C TO +125 °C
AGING		±5 PPM PER YEAR MAXIMUM
LOAD CAPACITANCE		10 TO 32 pF 0R SERIES
SHUNT CAPACITANCE		7 pF MAXIMUM
EQUIVALENT SERIES RESISTANCE (ESR)		SEE PAGE 11
DRIVE LEVEL		0.1 mW TYPICAL 1 mW MAXIMUM
SHOCK RESISTANCE		±5 PPM MAXIMUM 75 cm DROP TEST IN 3 AXES ONTO A HARD SURFACE OR 1000 g's x 0.5 ms x ½ SINEWAVE IN 3 AXES

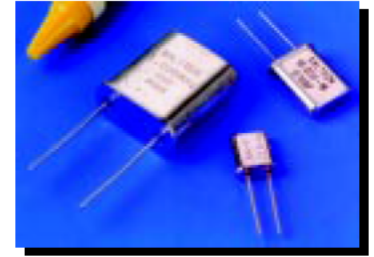

### ● FREQUENCY RANGE AND MODE OF OSCILLATION BY HOLDER TYPE

HOLDER TYPE	FUNDAMENTAL (FUND)	THIRD OVERTONE (3OT)	FIFTH OVERTONE (5OT)	SEVENTH OVERTONE (7OT)	NINTH OVERTONE (9OT)
TYPE A: HC-49/U	1.00 MHZ TO 65.00 MHZ	20.00 MHZ TO 90.00 MHZ	60.00 MHZ TO 130.00 MHZ	125.00 MHZ TO 200.00 MHZ	180.00 MHZ TO 300.00 MHZ
TYPE B: HC-51/U	100.00 KHZ TO 4.00 MHZ				
TYPE C: UM-1	8.00 MHZ TO 65.00 MHZ	25.00 MHZ TO 90.00 MHZ	60.00 MHZ TO 130.00 MHZ	125.00 MHZ TO 200.00 MHZ	180.00 MHZ TO 300.00 MHZ

### ● PART NUMBERING SYSTEM

HOLDER TYPE		FREQUENCY	LOAD CAPACITANCE	MODE		EXTENDED TEMPERATURE
A	HC-49/U	IN MHZ	10 TO 32pF FOR PARALLEL S FOR SERIES	F	FUNDAMENTAL	EXT
B	HC-51/U			3OT	THIRD OVERTONE	
C	UM-1			5OT	FIFTH OVERTONE	
				7OT	SEVENTH OVERTONE	
		9OT	NINTH OVERTONE			

MECHANICAL OPTIONS				TAPE AND REEL
THREE PIN BASE	THIRD LEAD (TOP OF HOUSING)	SPACER	SLEEVE	TR
3PIN	3RD	SP	SL	

† FUNDAMENTAL MODE NOT NEEDED IN PART NUMBER

EXAMPLE: A-4.000-S

A-3.579545-18-EXT-3PIN-SP-SL-TR

C-65.000-S-30T

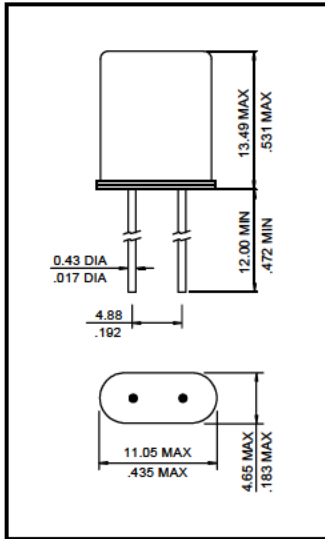

TYPE A (HC-49/U)

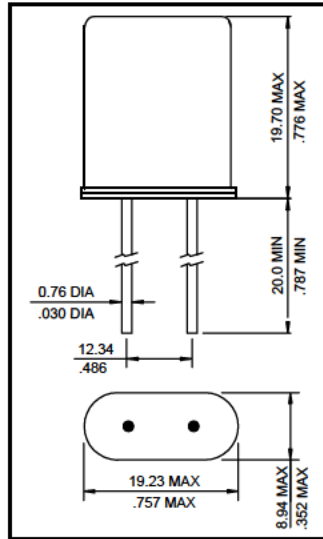

TYPE B (HC-51/U)

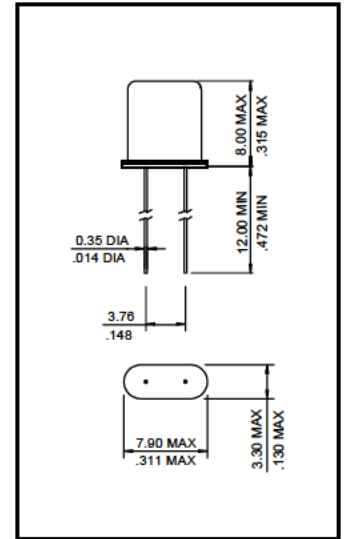

TYPE C (UM-1)

● PACKAGE OPTIONS

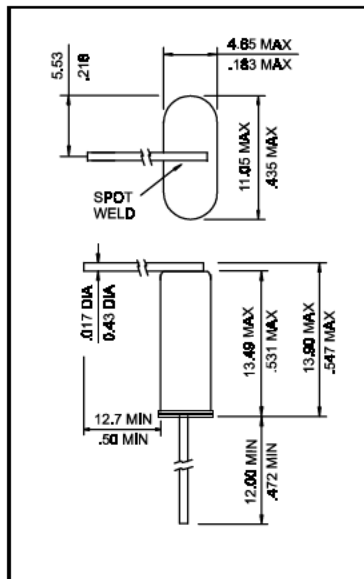

THIRD LEAD OPTION: 3RD

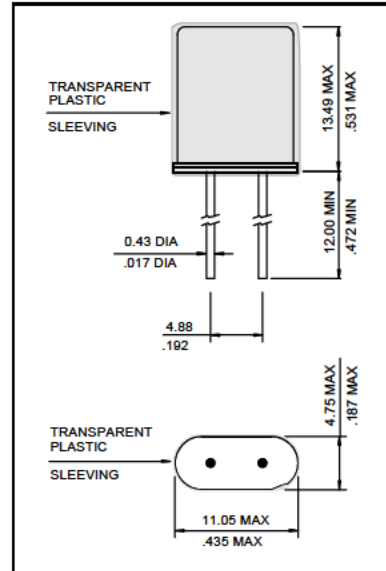

PLASTIC SLEEVE OPTION: SL

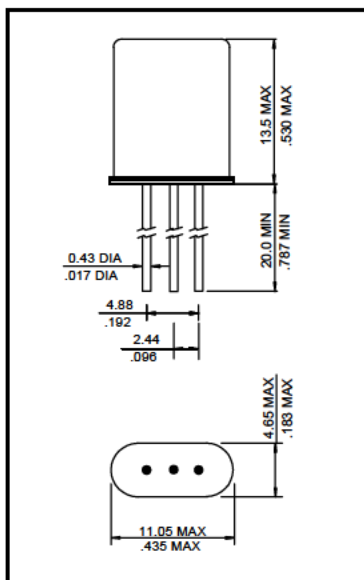

3 LEAD BASE OPTION: 3PIN

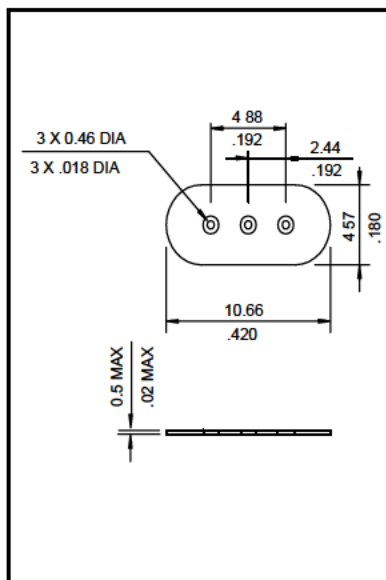

PLASTIC SPACER OPTION: SP

● EQUIVALENT SERIES RESISTANCE VERSUS FREQUENCY AND PACKAGE

FREQUENCY MHz	HOLDER TYPE			ESR		
	HC-51/U "B"	HC-49/U "A"	UM-1 "C"	"B"	"A"	"C"
1.000	B	A		700	700	
1.843	B	A		600	700	
2.000	B	A		500	500	
2.097152	B	A		500	500	
2.4576	B	A		400	400	
3.000	B	A		150	200	
3.2768	B	A		150	180	
3.579545	B	A		120	180	
3.600	B	A		100	160	
3.6864	B	A		100	140	
4.000	B	A		50	80	
4.096		A			80	
4.194304		A			80	
4.433619		A			80	
4.9152		A			60	
5.000		A			60	
5.0688		A			60	
5.185		A			60	
5.7143		A			50	
5.9904		A			50	
6.000		A			50	
6.144		A			40	
6.400		A			40	
6.5536		A			40	
7.000		A			30	
7.15909		A			30	
7.3728		A			30	
8.000		A			30	
9.216		A			30	
9.8304		A			30	
10.000		A	C	25	50	
10.738635		A	C	25	50	
11.000		A	C	25	50	
11.050		A	C	25	50	

FREQUENCY MHz	HOLDER TYPE			ESR		
	HC-51/U "B"	HC-49/U "A"	UM-1 "C"	"B"	"A"	"C"
11.059		A	C		25	50
12.000		A	C		25	40
12.288		A	C		25	40
13.5168		A	C		25	40
14.31818		A	C		25	35
14.7456		A	C		25	35
15.000		A	C		25	35
16.000		A	C		25	30
16.384		A	C		25	35
17.360		A	C		25	30
18.000		A	C		20	25
18.432		A	C		20	30
19.354		A	C		20	30
19.6608		A	C		20	30
20.000		A	C		20	30
22.1184		A	C		20	25
23.400		A	C		20	25
24.000		A	C		20	25
24.576		A	C		30	25
25.000		A	C		30	20
27.000		A	C		30	20
30.000		A	C		30	20
32.000		A	C		30	60
36.000		A	C		30	60
40.000		A	C		30	50
48.000		A	C		30	50
60.000		A	C		30	40
70.000		A	C		30	40
80.000		A	C		30	40
90.000		A	C		40	40
100.000		A	C		40	100
150.000		A	C		50	70
200.000		A	C		100	120
300.000		A	C		150	180

● CARRIER TAPE DIMENSIONS

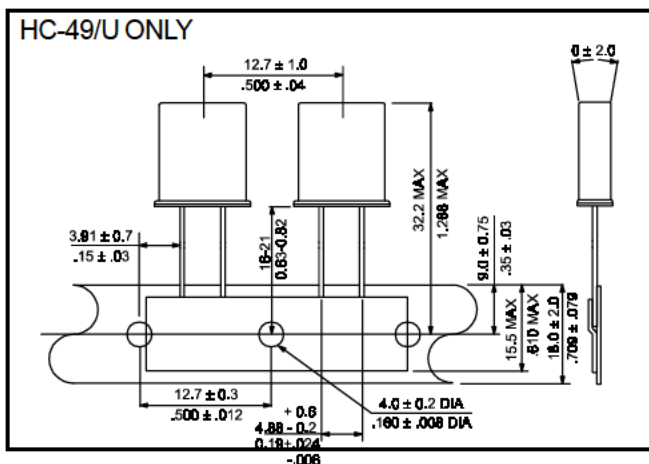

● PACKAGING

370 mm REEL DIAMETER, 18 mm TAPE WIDTH, 12.7 mm PITCH, QUANTITY 1000 PIECES PER REEL