

**NuMicro<sup>®</sup> Family**  
**Arm<sup>®</sup> Cortex<sup>®</sup>-M4-based Microcontroller**

**NuMaker-M467HJ**  
**User Manual**  
*Evaluation Board for NuMicro<sup>®</sup> M460 Series*

*The information described in this document is the exclusive intellectual property of Nuvoton Technology Corporation and shall not be reproduced without permission from Nuvoton.*

*Nuvoton is providing this document only for reference purposes of NuMicro microcontroller and microprocessor based system design. Nuvoton assumes no responsibility for errors or omissions.*

*All data and specifications are subject to change without notice.*

For additional information or questions, please contact: Nuvoton Technology Corporation.

[www.nuvoton.com](http://www.nuvoton.com)

**Table of Contents**

**1 OVERVIEW ..... 7**

**2 FEATURES ..... 8**

**3 HARDWARE CONFIGURATION ..... 9**

    3.1 Front View..... 9

    3.2 Rear View ..... 11

    3.3 Extension Connectors..... 12

        3.3.1 Pin Assignment for Extension Connectors .....12

        3.3.2 Arduino UNO Compatible Extension Connectors .....19

    3.4 Power Supply Configuration ..... 21

        3.4.1 VIN Power Source .....21

        3.4.2 5V Power Sources.....21

        3.4.3 3.3V Power Sources .....22

        3.4.4 Power Connectors.....22

        3.4.5 USB Connectors .....23

        3.4.6 Power Switches .....23

        3.4.7 Power Supply Models .....24

    3.5 External Reference Voltage Connector..... 28

    3.6 Ammeter Connector ..... 28

    3.7 Push Buttons..... 29

    3.8 LEDs..... 30

    3.9 Nu-Link2-Me..... 30

        3.9.1 VCOM Switches.....30

        3.9.2 Status LEDs .....31

**4 QUICK START ..... 32**

    4.1 Toolchains Supporting ..... 32

    4.2 Nuvoton Nu-Link Driver Installation ..... 32

    4.3 BSP Firmware Download ..... 34

    4.4 Hardware Setup..... 34

    4.5 Find the Example Project..... 36

    4.6 Execute the Project under Toolchains ..... 36

        4.6.1 Keil MDK.....36

        4.6.2 IAR EWARM.....40

        4.6.3 NuEclipse.....42

**5 NUMAKER-M467 SCHEMATICS ..... 49**

    5.1 Nu-Link2-Me..... 49

5.2 M467HJ Target Board ..... 50

    5.2.1 Power Source.....50

    5.2.2 M467HJHAN .....51

    5.2.3 HyperRAM .....52

    5.2.4 SPI Flash .....53

    5.2.5 Full-speed USB.....54

    5.2.6 High-speed USB.....55

    5.2.7 SD Card .....56

    5.2.8 Extension Connectors.....57

    5.2.9 Arduino UNO I/F .....58

    5.2.10 COMS I/F & LCD I/F .....59

    5.2.11 CAN FD Transceiver .....60

    5.2.12 Ethernet PHY .....61

    5.2.13 Audio .....62

    5.2.14 Thermal Sensor .....63

    5.2.15 LEDs & Buttons .....64

**6 REVISION HISTORY ..... 65**

**List of Figures**

Figure 1-1 NuMaker-M467HJ Evaluation Board ..... 7

Figure 3-1 Front View of NuMaker-M467HJ ..... 9

Figure 3-2 Rear View of NuMaker-M467HJ ..... 11

Figure 3-3 M467HJHAN Extension Connectors ..... 12

Figure 3-4 Arduino UNO Compatible Extension Connectors..... 19

Figure 3-5 External Power Supply Sources on Nu-Link2-Me ..... 24

Figure 3-6 External Power Supply Sources on M467HJ Target Board ..... 25

Figure 3-7 Detach the Nu-Link2-Me from NuMaker-M467HJ ..... 26

Figure 3-8 Wiring between Ammeter Connector and Ammeter..... 28

Figure 4-1 Nu-Link USB Driver Installation Setup..... 32

Figure 4-2 Nu-Link USB Driver Installation ..... 33

Figure 4-3 Open VCOM Function ..... 34

Figure 4-4 ICE USB Connector..... 34

Figure 4-5 Device Manger..... 35

Figure 4-6 PuTTY Session Setting..... 35

Figure 4-7 Template Project Folder Path..... 36

Figure 4-8 Warning Message of “Device not found” ..... 36

Figure 4-9 Project File Migrate to Version 5 Format..... 37

Figure 4-10 Debugger Setting in Options Window..... 37

Figure 4-11 Programming Setting in Options Window..... 38

Figure 4-12 Compile and Download the Project ..... 38

Figure 4-13 Keil MDK Debug Mode ..... 39

Figure 4-14 Debug Message on Serial Port Terminal Windows..... 39

Figure 4-15 IAR EWARM Window ..... 40

Figure 4-16 Compile and Download the Project ..... 40

Figure 4-17 IAR EWARM Debug Mode ..... 41

Figure 4-18 Debug Message on Serial Port Terminal Windows..... 41

Figure 4-19 Import the Project in NuEclipse ..... 42

Figure 4-20 Import Projects Windows..... 43

Figure 4-21 Open Project Properties Window ..... 43

Figure 4-22 Project Properties Settings ..... 44

Figure 4-23 Build Project..... 44

Figure 4-24 Open Debug Configuration..... 45

Figure 4-25 Main Tab Configuration ..... 45

Figure 4-26 Debugger Tab Configuration ..... 46

Figure 4-27 Startup Tab Configuration ..... 47

Figure 4-28 NuEclipse Debug Mode ..... 48

Figure 4-29 Debug Message on Serial Port Terminal Windows ..... 48

Figure 5-1 Nu-Link2-Me Circuit ..... 49

Figure 5-2 Power Source Circuit ..... 50

Figure 5-3 M467HJHAN Circuit..... 51

Figure 5-4 HyperRAM Circuit ..... 52

Figure 5-5 SPI Flash Circuit ..... 53

Figure 5-6 Full-speed USB Circuit ..... 54

Figure 5-7 High-speed Circuit ..... 55

Figure 5-8 SD Card Circuit ..... 56

Figure 5-9 Extension Connectors Circuit ..... 57

Figure 5-10 Arduino Uno I/F Circuit ..... 58

Figure 5-11 COMS and LCD I/F Circuit ..... 59

Figure 5-12 CAN FD Transceiver Circuit ..... 60

Figure 5-13 Ethernet PHY Circuit..... 61

Figure 5-14 Audio Circuit ..... 62

Figure 5-15 Thermal Sensor Circuit ..... 63

Figure 5-16 LEDs and Buttons Circuit ..... 64

**List of Tables**

Table 3-1 Extension Connectors..... 12

Table 3-2 M467HJHAN Full-pin Extension Connectors and GPIO Function List ..... 18

Table 3-3 Arduino UNO Extension Connectors and M467HJHAN Mapping GPIO List ..... 20

Table 3-4 Vin Power Source ..... 21

Table 3-5 5V Power Sources ..... 21

Table 3-6 3.3 V Power Sources ..... 22

Table 3-7 Power Connectors ..... 22

Table 3-8 USB Connectors ..... 23

Table 3-9 Power Switches ..... 23

Table 3-10 Supply External Power through Nu-Link2-Me ..... 24

Table 3-11 Supply External Power for M467HJ Target Board..... 27

Table 3-12 External Reference Voltage Connector ..... 28

Table 3-13 Ammeter Connector..... 28

Table 3-14 Push Buttons..... 29

Table 3-15 LEDs ..... 30

Table 3-16 VCOM Function of Nu-Link2-Me..... 30

Table 3-17 Operation Status LED Patterns ..... 31

## 1 OVERVIEW

The NuMaker-M467HJ is an evaluation board for Nuvoton NuMicro M467SJ, M467KJ, M467JJ, M467HJ microcontrollers. The NuMaker-M467HJ consists of two parts: an M467HJ target board and an on-board Nu-Link2-Me debugger and programmer. The NuMaker-M467HJ is designed for project evaluation, prototype development and validation with power consumption monitoring function.

The M467HJ target board is based on NuMicro M467HJHAN. For the development flexibility, the M467HJ target board provides the extension connectors, the Arduino UNO compatible headers and the capability of adopting multiple power supplies. Furthermore, the Nuvoton-designed ammeter connector can measure the power consumption instantly, which is essential for the prototype evaluation.

In addition, there is an attached on-board debugger and programmer “Nu-Link2-Me”. The Nu-Link2-Me supports on-chip debugging, online and offline ICP programming via SWD interface. The Nu-Link2-Me supports virtual COM (VCOM) port for printing debug messages on PC. Besides, the programming status could be shown on the built-in LEDs. Lastly, the Nu-Link2-Me could be detached from the evaluation board and become a stand-alone mass production programmer.

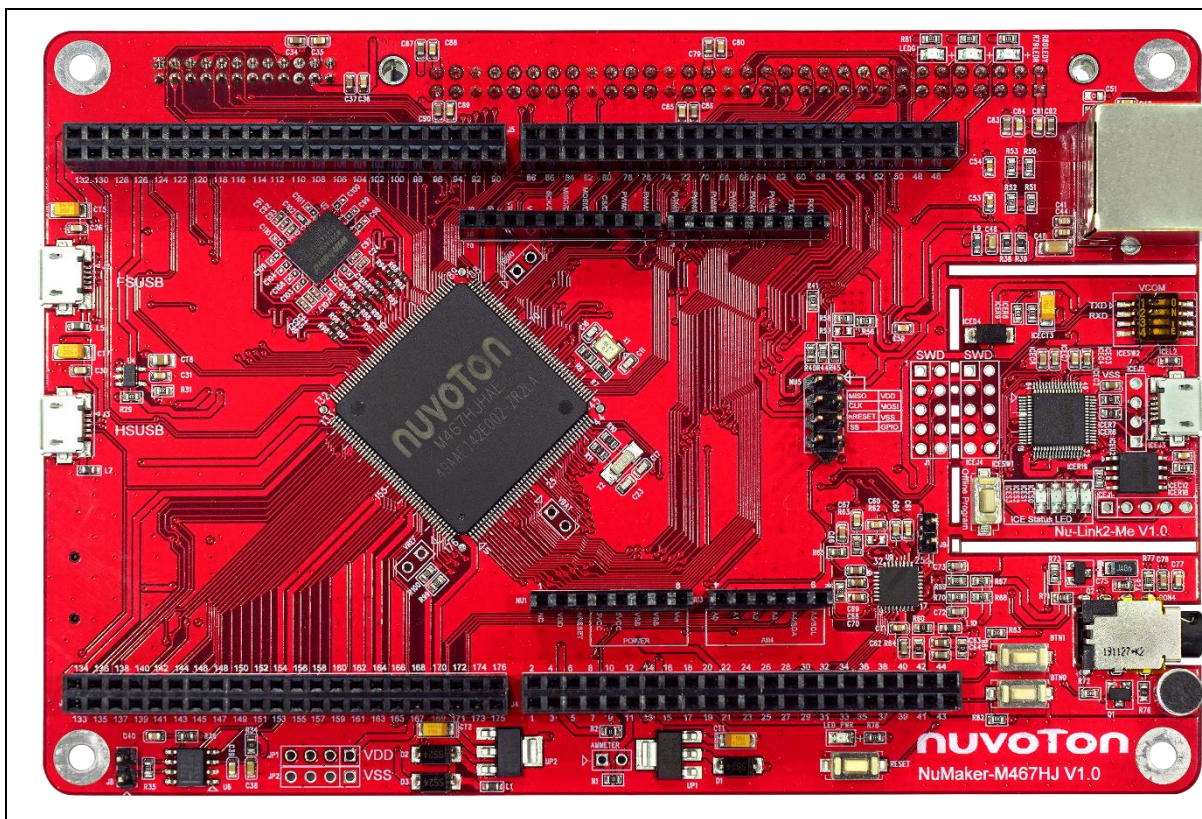

Figure 1-1 NuMaker-M467HJ Evaluation Board



## 2 FEATURES

- NuMicro M467HJHAN used as main microcontroller with function compatible with:
  - M467SJHAN
  - M467KJHAN
  - M467JJHAN
  - M467HJHAN
- M467HJHAN full pins extension connectors
- Arduino UNO compatible extension connectors
- Ammeter connector for measuring the microcontroller's power consumption
- Flexible board power supply:
  - External  $V_{DD}$  power connector
  - Arduino UNO compatible extension connector  $V_{in}$
  - USB FS connector on M467HJHAN target board
  - USB HS connector on M467HJHAN target board
  - ICE USB connector on Nu-Link2-Me
- On-board Nu-Link2-Me debugger and programmer:
  - Debug through SWD interface
  - Online/offline programming
  - Virtual COM port function
- On-board components:
  - 32Mb SPI Flash
  - 64Mb HyperRAM
  - [Thermal sensor \(Nuvoton NCT7717U\)](#)
  - User LEDs and user buttons
  - 10/100M ethernet PHY
  - FS-USB OTG and HS-USB OTG
  - Audio Codec
  - Micro SD Card slot
  - CAN FD transceiver



### 3 HARDWARE CONFIGURATION

#### 3.1 Front View

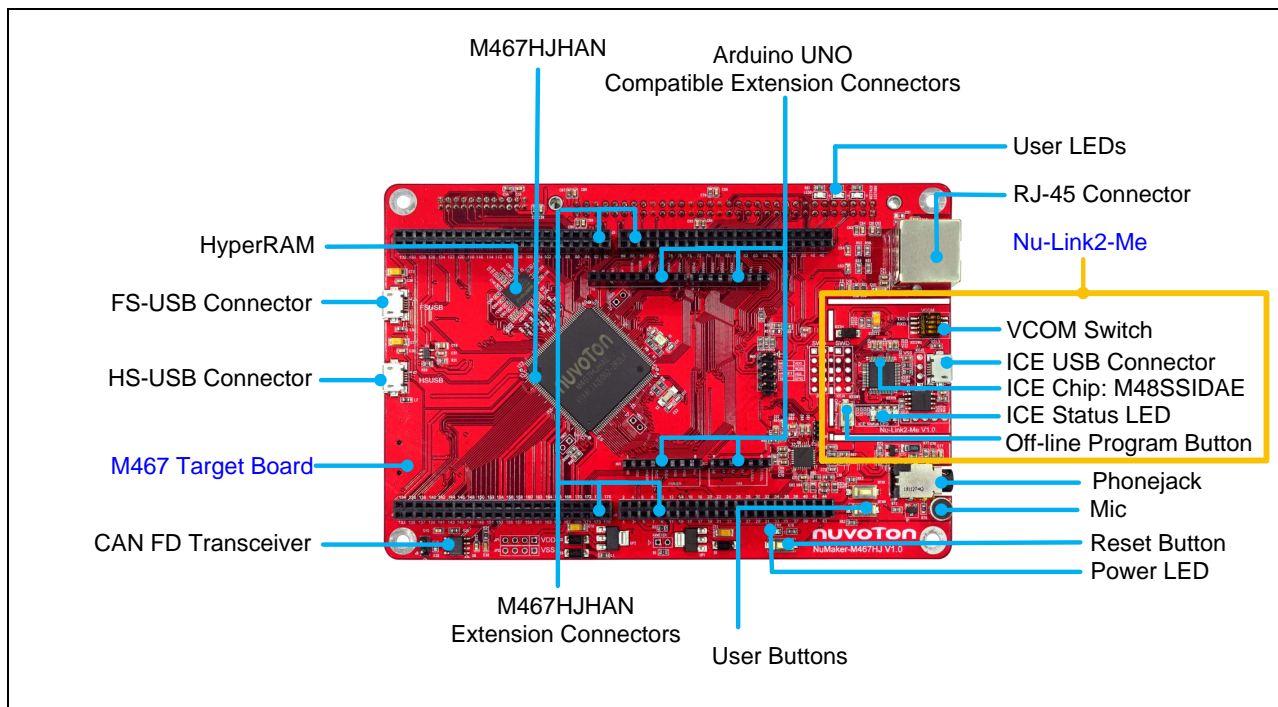

Figure 3-1 Front View of NuMaker-M467HJ

Figure 3-1 shows the main components and connectors from the front side of NuMaker-M467HJ. The following lists components and connectors from the front view:

- Target chip: M467HJHAN (U1)
- USB FS Connector (J2)
- USB HS Connector (J3)
- Arduino UNO Compatible Extension Connectors (NU1, NU2, NU3, NU4 and NU5)
- M467 Extension Connectors (J4, J5, J6 and J7)
- External  $V_{DD}$  Power Connector (JP1)
- External  $V_{SS}$  Power Connector (JP2)
- External  $V_{DDIO}$  Connector (VDDIO)
- External  $V_{BAT}$  Connector (VBAT)
- External  $V_{REF}$  Connector (VREF)
- Ammeter Connector (AMMETER)
- Reset Button (RESET)
- Power LED (LED\_PWR), PH4 Red LED (LED\_R), PH5 Yellow LED (LED\_Y) and PH6 Green LED (LED\_G)

- Nu-Link2-Me
  - VCOM Switch
  - ICE Chip: M48SSIDAE (ICEU2)
  - ICE USB Connector (ICEJ3)
  - ICE Status LED (ICES0, ICES1, ICES2, ICES3)
  - Off-line Program Button (ICESW1)

### 3.2 Rear View

Figure 3-2 shows the main components and connectors from the rear side of NuMaker-M467HJ.

The following lists components and connectors from the rear view:

- CMOS Sensor Connector (CON1)
- TFT LCD Panel Connector (CON2)
- SD Card Connector (U5) and SD Card Power LED (SD\_PWR)
- [Thermal Sensor \(U10, Nuvoton NCT7717U\)](#)
- SPI Flash (U11)
- Nu-Link2-Me
  - MCUVCC Power Switch (ICEJPR1)
  - ICEVCC Power Switch (ICEJPR2)

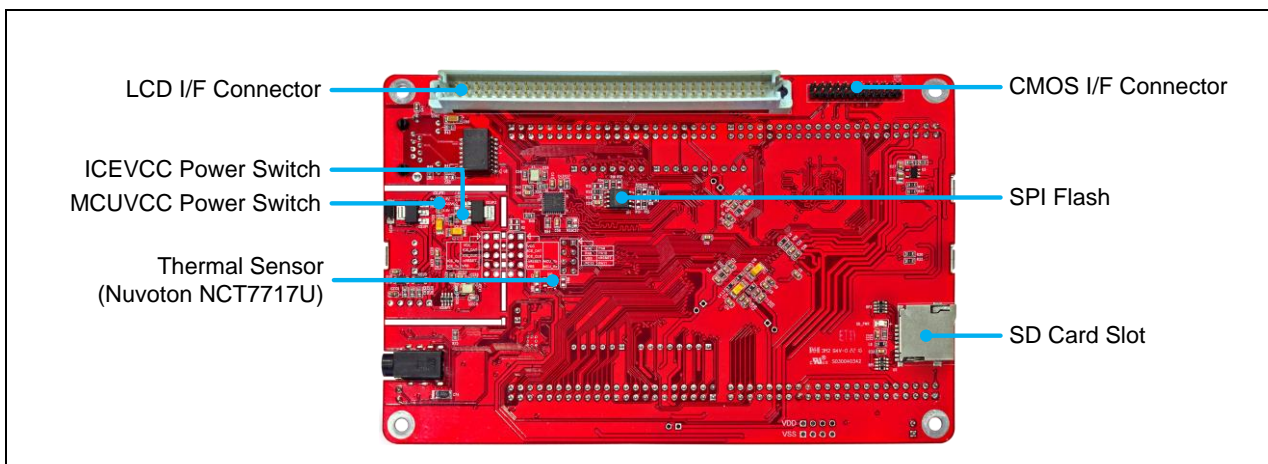

Figure 3-2 Rear View of NuMaker-M467HJ

### 3.3 Extension Connectors

Table 3-1 presents the extension connectors.

Connector	Description
J4, J5, J6 and J7	Full pins extension connectors on the NuMaker-M467HJ.
NU1, NU2, NU3, NU4 and NU5	Arduino UNO compatible pins on the NuMaker-M467HJ.
CON1	CMOS sensor connector on the NuMaker-M467HJ.
CON2	TFT LCD panel connector on the NuMaker-M467HJ

Table 3-1 Extension Connectors

#### 3.3.1 Pin Assignment for Extension Connectors

The NuMaker-M467HJ provides the M467HJHAN onboard and extension connectors (J4, J5, J6 and J7). Figure 3-3 shows the M467HJHAN extension connectors.

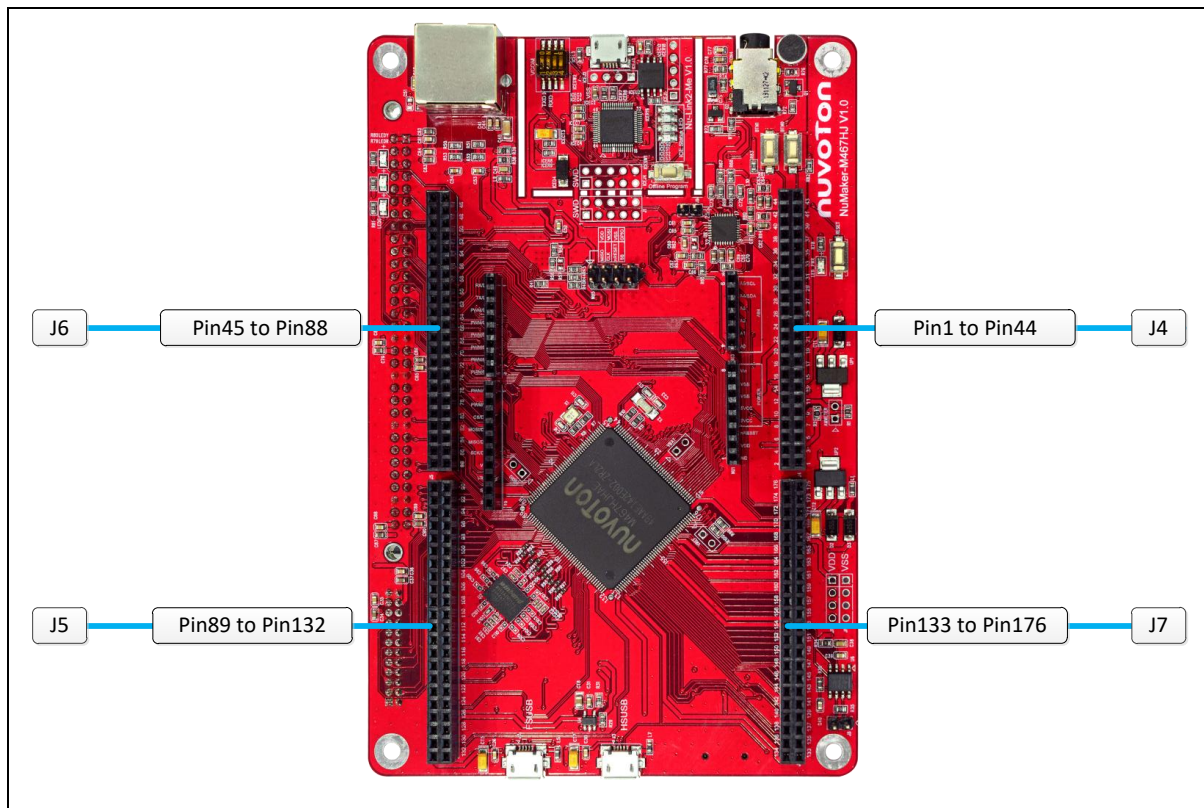

Figure 3-3 M467HJHAN Extension Connectors

Header		M467HJHAN	
		Pin No.	Function
JP4	JP4.1	1	PB.5 / EADC0_CH5 / ACOMP1_N / EBI_ADR0 / SD0_DAT3 / EMAC0_RMII_REFCLK / SPI1_MISO / I2C0_SCL / UART5_TXD / SC0_CLK / I2S0_BCLK / EPWM0_CH0 / UART2_TXD / TM0 / INT0 / PSIO0_CH4 / KPI_COL6
	JP4.2	2	PB.4 / EADC0_CH4 / ACOMP1_P1 / EBI_ADR1 / SD0_DAT2 / EMAC0_RMII_RXD0 / SPI1_MOSI / I2C0_SDA / UART5_RXD / SC0_DAT / I2S0_MCLK / EPWM0_CH1 / UART2_RXD / TM1 / INT1 / PSIO0_CH5 / KPI_COL7
	JP4.3	3	PB.3 / EADC0_CH3 / EADC1_CH11 / ACOMP0_N / EBI_ADR2 / SD0_DAT1 / EMAC0_RMII_RXD1 / SPI1_CLK / UART1_TXD / UART5_nRTS / SC0_RST / I2S0_DI / EPWM0_CH2 / I2C1_SCL / TM2 / INT2 / PSIO0_CH6 / KPI_ROW0
	JP4.4	4	PB.2 / EADC0_CH2 / EADC1_CH10 / ACOMP0_P1 / EBI_ADR3 / SD0_DAT0 / EMAC0_RMII_CRSDV / SPI1_SS / UART1_RXD / UART5_nCTS / SC0_PWR / I2S0_DO / EPWM0_CH3 / I2C1_SDA / TM3 / INT3 / PSIO0_CH7 / KPI_ROW1
	JP4.5	5	PC.12 / EADC2_CH13 / EBI_ADR4 / UART0_TXD / I2C0_SCL / UART6_TXD / SPI3_MISO / SC0_nCD / I2C4_SCL / ECAP1_IC2 / EPWM1_CH0 / ACOMP0_O
	JP4.6	6	PC.11 / EADC2_CH12 / ACOMP3_P3 / EBI_ADR5 / UART0_RXD / I2C0_SDA / UART6_RXD / SPI3_MOSI / I2C4_SDA / ECAP1_IC1 / EPWM1_CH1 / ACOMP1_O
	JP4.7	7	PC.10 / EADC2_CH11 / ACOMP3_P2 / EBI_ADR6 / UART6_nRTS / SPI3_CLK / UART3_TXD / CAN1_TXD / I2C4_SMBAL / ECAP1_IC0 / EPWM1_CH2 / EADC1_ST
	JP4.8	8	PC.9 / EADC2_CH10 / ACOMP3_P1 / EBI_ADR7 / UART6_nCTS / SPI3_SS / UART3_RXD / CAN1_RXD / I2C4_SMBUS / EPWM1_CH3 / EADC1_ST
	JP4.9	9	PB.1 / EADC0_CH1 / EADC1_CH9 / EADC2_CH9 / ACOMP3_P0 / EBI_ADR8 / SD0_CLK / EMAC0_RMII_RXERR / SPI1_I2SMCLK / SPI3_I2SMCLK / UART2_TXD / I2C1_SCL / I2S0_LRCK / EPWM0_CH4 / EPWM1_CH4 / EPWM0_BRAKE0 / ACOMP2_O / QSPI0_MISO1 / KPI_ROW2
	JP4.10	10	PB.0 / EADC0_CH0 / EADC1_CH8 / EADC2_CH8 / ACOMP3_N / EBI_ADR9 / SD0_CMD / SPI2_I2SMCLK / USCIO_CTL0 / UART2_RXD / SPI0_I2SMCLK / I2C1_SDA / I2S1_LRCK / EPWM0_CH5 / EPWM1_CH5 / EPWM0_BRAKE1 / ACOMP3_O / QSPI0_MOSI1 / KPI_ROW3
	JP4.11	11	V <sub>SS</sub>
	JP4.12	12	V <sub>DD</sub>
	JP4.13	13	PA.11 / EADC1_CH7 / EADC2_CH7 / ACOMP0_P0 / EBI_nRD / SC2_PWR / SPI2_SS / SD1_DAT3 / USCIO_CLK / I2C2_SCL / UART6_TXD / BPWM0_CH0 / EPWM0_SYNC_OUT / I2S1_BCLK / TM0_EXT / DAC1_ST / KPI_ROW4
	JP4.14	14	PA.10 / EADC1_CH6 / EADC2_CH6 / ACOMP1_P0 / EBI_nWR / SC2_RST / SPI2_CLK / SD1_DAT2 / USCIO_DAT0 / I2C2_SDA / UART6_RXD / BPWM0_CH1 / EQEI1_INDEX / ECAP0_IC0 / I2S1_MCLK / TM1_EXT / DAC0_ST / SWDH_CLK / KPI_ROW5
	JP4.15	15	PA.9 / EADC1_CH5 / EADC2_CH5 / EBI_MCLK / SC2_DAT / SPI2_MISO / SD1_DAT1 / USCIO_DAT1 / UART1_TXD / UART7_TXD / BPWM0_CH2 / EQEI1_A / ECAP0_IC1 / I2S1_DI / TM2_EXT / SWDH_DAT
	JP4.16	16	PA.8 / EADC1_CH4 / EADC2_CH4 / EBI_ALE / SC2_CLK / SPI2_MOSI / SD1_DAT0 / USCIO_CTL1 / UART1_RXD / UART7_RXD / BPWM0_CH3 / EQEI1_B / ECAP0_IC2 / I2S1_DO / TM3_EXT / INT4
	JP4.17	17	PC.13 / EADC1_CH3 / EADC2_CH3 / EBI_ADR10 / SC2_nCD / SPI2_I2SMCLK / CAN1_TXD / USCIO_CTL0 / UART2_TXD / UART8_nCTS / BPWM0_CH4 / CLKO / EADC0_ST
	JP4.18	18	PD.12 / EADC1_CH2 / EADC2_CH2 / EBI_nCS0 / CAN1_RXD / UART2_RXD / UART8_nRTS / BPWM0_CH5 / EQEI0_INDEX / ECAP3_IC0 / CLKO / EADC0_ST / INT5
	JP4.19	19	PD.11 / EADC1_CH1 / EADC2_CH1 / EBI_nCS1 / UART1_TXD / CAN0_TXD / UART8_TXD / EQEI0_A / ECAP3_IC1 / INT6
	JP4.20	20	PD.10 / EADC1_CH0 / EADC2_CH0 / EBI_nCS2 / UART1_RXD / CAN0_RXD / UART8_RXD / EQEI0_B / ECAP3_IC2 / INT7
	JP4.21	21	V <sub>SS</sub>
	JP4.22	22	V <sub>DD</sub>
	JP4.23	23	PG.0 / EBI_ADR8 / I2C0_SCL / I2C1_SMBAL / UART2_RXD / CAN1_TXD / UART1_TXD / I2C3_SCL
	JP4.24	24	PG.1 / EBI_ADR9 / SPI2_I2SMCLK / I2C0_SDA / I2C1_SMBUS / UART2_TXD / CAN1_RXD / UART1_RXD / I2C3_SDA
	JP4.25	25	PG.2 / EBI_ADR11 / SPI2_SS / I2C0_SMBAL / I2C1_SCL / CCAP_DATA7 / I2C3_SMBAL / TM0
	JP4.26	26	PG.3 / EBI_ADR12 / SPI2_CLK / I2C0_SMBUS / I2C1_SDA / CCAP_DATA6 / I2C3_SMBUS / TM1
	JP4.27	27	PG.4 / EBI_ADR13 / SPI2_MISO / CCAP_DATA5 / TM2
	JP4.28	28	PI.6 / SC1_nCD / I2S0_BCLK / SPI1_I2SMCLK / UART2_TXD / I2C1_SCL / CAN3_TXD / USB_VBUS_ST

Header		M467HJHAN	
		Pin No.	Function
JP4	JP4.29	29	PI.7 / SC1_PWR / I2S0_MCLK / SPI1_MISO / UART2_RXD / I2C1_SDA / CAN3_RXD / USB_VBUS_EN
	JP4.30	30	PI.8 / SC1_RST / I2S0_DI / SPI1_MOSI / UART2_nRTS / I2C0_SMBAL / CAN2_TXD
	JP4.31	31	PI.9 / SC1_DAT / I2S0_DO / SPI1_CLK / UART2_nCTS / I2C0_SMBSUS / CAN2_RXD
	JP4.32	32	PI.10 / SC1_CLK / I2S0_LRCK / SPI1_SS / UART2_TXD / I2C0_SCL / CAN3_TXD
	JP4.33	33	PI.11 / UART2_RXD / I2C0_SDA / CAN3_RXD
	JP4.34	34	PF.11 / EBI_ADR14 / SPI2_MOSI / UART5_TXD / CCAP_DATA4 / CAN3_TXD / TAMPER5 / UART9_nCTS / TM3
	JP4.35	35	PF.10 / EBI_ADR15 / SC0_nCD / I2S0_BCLK / SPI0_I2SMCLK / UART5_RXD / CCAP_DATA3 / CAN3_RXD / TAMPER4 / UART9_nRTS
	JP4.36	36	PF.9 / EBI_ADR16 / SC0_PWR / I2S0_MCLK / SPI0_SS / UART5_nRTS / CCAP_DATA2 / CAN1_TXD / TAMPER3 / UART9_TXD
	JP4.37	37	PF.8 / EBI_ADR17 / SC0_RST / I2S0_DI / SPI0_CLK / UART5_nCTS / CCAP_DATA1 / CAN1_RXD / TAMPER2 / UART9_RXD
	JP4.38	38	PF.7 / EBI_ADR18 / SC0_DAT / I2S0_DO / SPI0_MISO / UART4_TXD / CCAP_DATA0 / CAN2_TXD / TAMPER1
	JP4.39	39	PF.6 / EBI_ADR19 / SC0_CLK / I2S0_LRCK / SPI0_MOSI / UART4_RXD / EBI_nCS0 / CAN2_RXD / SPI3_I2SMCLK / TAMPER0 / EQEI2_INDEX / TRACE_SWO
	JP4.40	40	V <sub>BAT</sub>
	JP4.41	41	PF.5 / UART2_RXD / EBI_AD1 / UART2_nCTS / EPWM0_CH0 / BPWM0_CH4 / EPWM0_SYNC_OUT / X32_IN / EADC0_ST / I2C4_SCL / EQEI2_A
	JP4.42	42	PF.4 / UART2_TXD / EBI_AD0 / UART2_nRTS / EPWM0_CH1 / BPWM0_CH5 / X32_OUT / EADC1_ST / I2C4_SDA / EQEI2_B
	JP4.43	43	PH.0 / EBI_ADR7 / UART5_TXD / TM0_EXT
	JP4.44	44	PH.1 / EBI_ADR6 / UART5_RXD / TM1_EXT
JP6	JP6.1	45	PH.2 / EBI_ADR5 / UART5_nRTS / UART4_TXD / I2C0_SCL / TM2_EXT
	JP6.2	46	PH.3 / EBI_ADR4 / SPI1_I2SMCLK / UART5_nCTS / UART4_RXD / I2C0_SDA / TM3_EXT
	JP6.3	47	PH.4 / EBI_ADR3 / SPI1_MISO / UART7_nRTS / UART6_TXD
	JP6.4	48	PH.5 / EBI_ADR2 / SPI1_MOSI / UART7_nCTS / UART6_RXD
	JP6.5	49	PH.6 / EBI_ADR1 / SPI1_CLK / UART7_TXD / UART9_nCTS
	JP6.6	50	PH.7 / EBI_ADR0 / SPI1_SS / UART7_RXD / UART9_nRTS
	JP6.7	51	PF.3 / EBI_nCS0 / UART0_TXD / I2C0_SCL / UART9_TXD / XT1_IN / BPWM1_CH0 / I2C4_SMBAL / ACMP2_O / EADC2_ST
	JP6.8	52	PF.2 / EBI_nCS1 / UART0_RXD / I2C0_SDA / QSPI0_CLK / UART9_RXD / XT1_OUT / BPWM1_CH1 / I2C4_SMBSUS / ACMP3_O
	JP6.9	53	V <sub>SS</sub>
	JP6.10	54	V <sub>DD</sub>
	JP6.11	55	PE.8 / EBI_ADR10 / EMAC0_RMII_MDC / I2S0_BCLK / SPI2_CLK / UART2_TXD / EPWM0_CH0 / EPWM0_BRAKE0 / ECAP0_IC0 / EQEI2_INDEX / TRACE_DATA3 / ECAP3_IC0
	JP6.12	56	PE.9 / EBI_ADR11 / EMAC0_RMII_MDIO / I2S0_MCLK / SPI2_MISO / UART2_RXD / EPWM0_CH1 / EPWM0_BRAKE1 / ECAP0_IC1 / EQEI2_A / TRACE_DATA2 / ECAP3_IC1
	JP6.13	57	PE.10 / EBI_ADR12 / EMAC0_RMII_TXD0 / I2S0_DI / SPI2_MOSI / UART3_TXD / EPWM0_CH2 / EPWM1_BRAKE0 / ECAP0_IC2 / EQEI2_B / TRACE_DATA1 / ECAP3_IC2
JP6.14	58	PE.11 / EBI_ADR13 / EMAC0_RMII_TXD1 / I2S0_DO / SPI2_SS / UART3_RXD / UART1_nCTS / EPWM0_CH3 / EPWM1_BRAKE1 / ECAP1_IC2 / TRACE_DATA0 / KPI_COL7	
JP6.15	59	PE.12 / EBI_ADR14 / EMAC0_RMII_TXEN / I2S0_LRCK / SPI2_I2SMCLK / UART1_nRTS / EPWM0_CH4 / ECAP1_IC1 / TRACE_CLK / KPI_COL6	
JP6.16	60	PE.13 / EBI_ADR15 / EMAC0_PPS / I2C0_SCL / UART4_nRTS / UART1_TXD / EPWM0_CH5 / EPWM1_CH0 / BPWM1_CH5 / ECAP1_IC0 / TRACE_SWO / KPI_COL5	
JP6.17	61	PC.8 / EBI_ADR16 / EMAC0_RMII_REFCLK / I2C0_SDA / UART4_nCTS / UART1_RXD / EPWM1_CH1 / BPWM1_CH4 / KPI_COL4	



Header		M467HJHAN		
		Pin No.	Function	
JP6	JP6.18	62	PC.7 / EBI_AD9 / EMAC0_RMII_RXD0 / SPI1_MISO / UART4_TXD / SC2_PWR / UART0_nCTS / I2C1_SMBAL / UART6_TXD / ACMP2_WLAT / EPWM1_CH2 / BPWM1_CH0 / CAN3_TXD / TM0 / INT3 / KPI_COL3	
	JP6.19	63	PC.6 / EBI_AD8 / EMAC0_RMII_RXD1 / SPI1_MOSI / UART4_RXD / SC2_RST / UART0_nRTS / I2C1_SMBSUS / UART6_RXD / ACMP3_WLAT / EPWM1_CH3 / BPWM1_CH1 / CAN3_RXD / TM1 / INT2 / KPI_COL2	
	JP6.20	64	PA.7 / EBI_AD7 / EMAC0_RMII_CRSDV / SPI1_CLK / SC2_DAT / UART0_TXD / I2C1_SCL / QSPI1_MISO1 / EPWM1_CH4 / BPWM1_CH2 / ACMP0_WLAT / TM2 / INT1 / KPI_COL1	
	JP6.21	65	PA.6 / EBI_AD6 / EMAC0_RMII_RXERR / SPI1_SS / SD1_nCD / SC2_CLK / UART0_RXD / I2C1_SDA / QSPI1_MOSI1 / EPWM1_CH5 / BPWM1_CH3 / ACMP1_WLAT / TM3 / INT0 / KPI_COLO	
	JP6.22	66	PI.12 / SPIM_SS / QSPI0_MISO1 / CAN0_TXD / UART4_TXD / EPWM1_CH0 / I2C3_SMBAL	
	JP6.23	67	PI.13 / SPIM_MISO / QSPI0_MOSI1 / CAN0_RXD / UART4_RXD / EPWM1_CH1 / I2C3_SMBSUS	
	JP6.24	68	PI.14 / SPIM_D2 / QSPI0_SS / UART8_nCTS / CAN1_TXD / UART3_TXD / EPWM1_CH2 / I2C3_SCL	
	JP6.25	69	PI.15 / SPIM_D3 / QSPI0_CLK / UART8_nRTS / CAN1_RXD / UART3_RXD / EPWM1_CH3 / I2C3_SDA	
	JP6.26	70	PJ.0 / SPIM_CLK / QSPI0_MISO0 / UART8_TXD / CAN2_TXD / EPWM1_CH4	
	JP6.27	71	PJ.1 / SPIM_MOSI / QSPI0_MOSI0 / UART8_RXD / CAN2_RXD / EPWM1_CH5	
	JP6.28	72	V <sub>SS</sub>	
	JP6.29	73	V <sub>DD</sub>	
	JP6.30	74	LDO_CAP	
	JP6.31	75	PA.5 / SPIM_D2 / QSPI0_MISO1 / SPI1_I2SMCLK / SD1_CMD / SC2_nCD / UART0_nCTS / UART5_TXD / I2C0_SCL / CAN0_TXD / UART0_TXD / BPWM0_CH5 / EPWM0_CH0 / EQEI0_INDEX	
	JP6.32	76	PA.4 / SPIM_D3 / QSPI0_MOSI1 / SPI0_I2SMCLK / SD1_CLK / SC0_nCD / UART0_nRTS / UART5_RXD / I2C0_SDA / CAN0_RXD / UART0_RXD / BPWM0_CH4 / EPWM0_CH1 / EQEI0_A	
	JP6.33	77	PA.3 / SPIM_SS / QSPI0_SS / SPI0_SS / SD1_DAT3 / SC0_PWR / UART4_TXD / UART1_TXD / I2C1_SCL / I2C0_SMBAL / BPWM0_CH3 / EPWM0_CH2 / EQEI0_B / EPWM1_BRAKE1 / PSIO0_CH4	
	JP6.34	78	PA.2 / SPIM_CLK / QSPI0_CLK / SPI0_CLK / SD1_DAT2 / SC0_RST / UART4_RXD / UART1_RXD / I2C1_SDA / I2C0_SMBSUS / BPWM0_CH2 / EPWM0_CH3 / EQEI3_INDEX / PSIO0_CH5	
	JP6.35	79	PA.1 / SPIM_MISO / QSPI0_MISO0 / SPI0_MISO / SD1_DAT1 / SC0_DAT / UART0_TXD / UART1_nCTS / I2C2_SCL / CCAP_DATA7 / BPWM0_CH1 / EPWM0_CH4 / EQEI3_A / DAC1_ST / PSIO0_CH6	
	JP6.36	80	PA.0 / SPIM_MOSI / QSPI0_MOSI0 / SPI0_MOSI / SD1_DAT0 / SC0_CLK / UART0_RXD / UART1_nRTS / I2C2_SDA / CCAP_DATA6 / BPWM0_CH0 / EPWM0_CH5 / EQEI3_B / DAC0_ST / PSIO0_CH7	
	JP6.37	81	V <sub>DDIO</sub>	
	JP6.38	82	PE.14 / EBI_AD8 / UART2_TXD / CAN0_TXD / SD1_nCD / UART6_TXD / PSIO0_CH0	
	JP6.39	83	PE.15 / EBI_AD9 / UART2_RXD / CAN0_RXD / UART6_RXD / PSIO0_CH1	
	JP6.40	84	nRESET	
	JP6.41	85	PF.0 / UART1_TXD / I2C1_SCL / UART0_TXD / SC1_DAT / I2S0_DO / UART2_TXD / I2C0_SCL / CAN2_TXD / EPWM1_CH4 / BPWM1_CH0 / ACMP0_O / ICE_DAT / EADC0_ST	
	JP6.42	86	PF.1 / UART1_RXD / I2C1_SDA / UART0_RXD / SC1_CLK / I2S0_LRCK / UART2_RXD / I2C0_SDA / CAN2_RXD / EPWM1_CH5 / BPWM1_CH1 / ACMP1_O / ICE_CLK / EADC1_ST	
	JP6.43	87	PD.9 / EBI_AD7 / I2C2_SCL / UART2_nCTS / UART7_TXD / CAN2_TXD / PSIO0_CH2	
	JP6.44	88	PD.8 / EBI_AD6 / I2C2_SDA / UART2_nRTS / UART7_RXD / CAN2_RXD / PSIO0_CH3	
	JP5	JP5.1	89	PC.5 / EBI_AD5 / SPIM_D2 / QSPI0_MISO1 / UART2_TXD / I2C1_SCL / CAN0_TXD / UART4_TXD / EPWM1_CH0 / CCAP_DATA5 / QSPI1_SS / I2C3_SMBAL / HBI_nCK / PSIO0_CH0 / KPI_ROW0
		JP5.2	90	PC.4 / EBI_AD4 / SPIM_D3 / QSPI0_MOSI1 / SC1_nCD / I2S0_BCLK / SPI1_I2SMCLK / UART2_RXD / I2C1_SDA / CAN0_RXD / UART4_RXD / EPWM1_CH1 / CCAP_DATA4 / QSPI1_CLK / I2C3_SMBSUS / HBI_CLK / PSIO0_CH1 / KPI_ROW1



Header		M467HJHAN	
		Pin No.	Function
JP5.3	91	PC.3 / EBI_AD3 / SPIM_SS / QSPI0_SS / SC1_PWR / I2S0_MCLK / SPI1_MISO / UART2_nRTS / I2C0_SMBAL / CAN1_TXD / UART3_TXD / EPWM1_CH2 / CCAP_DATA3 / QSPI1_MISO0 / I2C3_SCL / HBI_nCS / PSIO0_CH2 / KPI_ROW2	
JP5.4	92	PC.2 / EBI_AD2 / SPIM_CLK / QSPI0_CLK / SC1_RST / I2S0_DI / SPI1_MOSI / UART2_nCTS / I2C0_SMBSUS / CAN1_RXD / UART3_RXD / EPWM1_CH3 / CCAP_DATA2 / QSPI1_MOSIO / I2C3_SDA / HBI_nRESET / PSIO0_CH3 / KPI_ROW3	
JP5.5	93	PC.1 / EBI_AD1 / SPIM_MISO / QSPI0_MISO0 / SC1_DAT / I2S0_DO / SPI1_CLK / UART2_TXD / I2C0_SCL / CAN2_TXD / EPWM1_CH4 / CCAP_DATA1 / ACMP0_O / EADC0_ST / HBI_RWDS / KPI_ROW4	
JP5.6	94	PC.0 / EBI_AD0 / SPIM_MOSI / QSPI0_MOSIO / SC1_CLK / I2S0_LRCK / SPI1_SS / UART2_RXD / I2C0_SDA / CAN2_RXD / EPWM1_CH5 / CCAP_DATA0 / ACMP1_O / EADC1_ST / HBI_D2 / KPI_ROW5	
JP5.7	95	V <sub>SS</sub>	
JP5.8	96	V <sub>DD</sub>	
JP5.9	97	PG.9 / EBI_AD0 / SD1_DAT3 / SPIM_D2 / QSPI1_MISO1 / CCAP_PIXCLK / I2C4_SCL / ECAP2_IC0 / BPWM0_CH5 / HBI_D4	
JP5.10	98	PG.10 / EBI_AD1 / SD1_DAT2 / SPIM_D3 / QSPI1_MOSI1 / CCAP_SCLK / I2C4_SDA / ECAP2_IC1 / BPWM0_CH4 / HBI_D3	
JP5.11	99	PG.11 / EBI_AD2 / SD1_DAT1 / SPIM_SS / QSPI1_SS / UART7_TXD / CCAP_SFIELD / I2C4_SMBAL / ECAP2_IC2 / BPWM0_CH3 / HBI_D0	
JP5.12	100	PG.12 / EBI_AD3 / SD1_DAT0 / SPIM_CLK / QSPI1_CLK / UART7_RXD / CCAP_VSYNC / I2C4_SMBSUS / BPWM0_CH2 / HBI_D1	
JP5.13	101	PG.13 / EBI_AD4 / SD1_CMD / SPIM_MISO / QSPI1_MISO0 / UART6_TXD / CCAP_HSYNC / BPWM0_CH1 / HBI_D5	
JP5.14	102	PG.14 / EBI_AD5 / SD1_CLK / SPIM_MOSI / QSPI1_MOSIO / UART6_RXD / BPWM0_CH0 / HBI_D6	
JP5.15	103	PG.15 / SD1_nCD / CLKO / EADC0_ST / HBI_D7	
JP5.16	104	PJ.2 / EBI_AD5 / UART8_nCTS / QSPI1_SS / CCAP_DATA5 / CAN0_TXD / HBI_nRESET	
JP5.17	105	PJ.3 / EBI_AD4 / UART8_nRTS / QSPI1_CLK / CCAP_DATA4 / CAN0_RXD / HBI_D3	
JP5.18	106	PJ.4 / EBI_AD3 / UART8_TXD / QSPI1_MISO0 / CCAP_DATA3 / CAN1_TXD / HBI_D2	
JP5.19	107	PJ.5 / EBI_AD2 / UART8_RXD / QSPI1_MOSIO / CCAP_DATA2 / CAN1_RXD / HBI_D1	
JP5.20	108	PJ.6 / EBI_AD1 / UART9_nCTS / CCAP_DATA1 / CAN2_TXD / HBI_D0	
JP5.21	109	PJ.7 / EBI_AD0 / UART9_nRTS / CCAP_DATA0 / CAN2_RXD / HBI_nCS	
JP5.22	110	PH.12 / EBI_AD0 / UART9_TXD / QSPI1_MISO1 / CCAP_PIXCLK / CAN3_TXD / HBI_nCK	
JP5.23	111	PH.13 / EBI_AD1 / UART9_RXD / QSPI1_MOSI1 / CCAP_SCLK / CAN3_RXD / HBI_nCK	
JP5.24	112	PH.14 / EBI_AD2 / QSPI1_SS / CCAP_SFIELD / HBI_RWDS	
JP5.25	113	PH.15 / EBI_AD3 / QSPI1_CLK / CCAP_VSYNC / HBI_D4	
JP5.26	114	PD.7 / EBI_AD4 / UART1_TXD / I2C0_SCL / SPI1_MISO / QSPI1_MISO0 / CCAP_HSYNC / SC1_PWR / HBI_D5 / PSIO0_CH4	
JP5.27	115	PD.6 / EBI_AD5 / UART1_RXD / I2C0_SDA / SPI1_MOSI / QSPI1_MOSIO / SC1_RST / ACMP0_O / EADC0_ST / HBI_D6 / PSIO0_CH5	
JP5.28	116	PD.5 / I2C1_SCL / SPI1_CLK / SC1_DAT / ACMP1_O / EADC1_ST / HBI_D7 / PSIO0_CH6	
JP5.29	117	PD.4 / USCIO_CTL0 / I2C1_SDA / SPI1_SS / SC1_CLK / USB_VBUS_ST / PSIO0_CH7	
JP5.30	118	PD.3 / EBI_AD10 / USCIO_CTL1 / SPI0_SS / UART3_nRTS / SC2_PWR / SC1_nCD / UART0_TXD / I2S1_BCLK / EQEI3_A	
JP5.31	119	PD.2 / EBI_AD11 / USCIO_DAT1 / SPI0_CLK / UART3_nCTS / SC2_RST / UART0_RXD / I2S1_MCLK / EQEI3_B	
JP5.32	120	PD.1 / EBI_AD12 / USCIO_DAT0 / SPI0_MISO / UART3_TXD / I2C2_SCL / SC2_DAT / I2S1_DI / EQEI2_INDEX / ECAP2_IC0	
JP5.33	121	PD.0 / EBI_AD13 / USCIO_CLK / SPI0_MOSI / UART3_RXD / I2C2_SDA / SC2_CLK / I2S1_DO / EQEI2_A / ECAP2_IC1 / TM2	

Header		M467HJHAN		
		Pin No.	Function	
JP5	JP5.34	122	PD.13 / EBI_AD10 / SD0_nCD / SPI0_I2SMCLK / SPI1_I2SMCLK / QSPI1_MOSI0 / SC2_nCD / SD1_CLK / UART6_RXD / I2S1_LRCK / BPWM0_CH0 / EQEI2_B / ECAP2_IC2 / CLK0 / EADC0_ST	
	JP5.35	123	PA.12 / I2S0_BCLK / UART4_TXD / I2C1_SCL / SPI2_SS / CAN0_TXD / SC2_PWR / SD1_nCD / QSPI1_MISO0 / BPWM1_CH2 / EQEI1_INDEX / ECAP3_IC0 / USB_VBUS / PSIO0_CH4	
	JP5.36	124	PA.13 / I2S0_MCLK / UART4_RXD / I2C1_SDA / SPI2_CLK / CAN0_RXD / SC2_RST / QSPI1_MOSI0 / BPWM1_CH3 / EQEI1_A / ECAP3_IC1 / USB_D- / PSIO0_CH5	
	JP5.37	125	PA.14 / I2S0_DI / UART0_TXD / EBI_AD5 / SPI2_MISO / I2C2_SCL / SC2_DAT / BPWM1_CH4 / EQEI1_B / ECAP3_IC2 / USB_D+ / PSIO0_CH6	
	JP5.38	126	PA.15 / I2S0_DO / UART0_RXD / SPIM_MOSI / SPI2_MOSI / I2C2_SDA / SC2_CLK / BPWM1_CH5 / EPWM0_SYNC_IN / EQEI3_INDEX / USB_OTG_ID / PSIO0_CH7	
	JP5.39	127	HSUSB_VRES	
	JP5.40	128	HSUSB_VDD33	
	JP5.41	129	HSUSB_VBUS	
	JP5.42	130	HSUSB_D-	
	JP5.43	131	HSUSB_VSS	
	JP5.44	132	HSUSB_D+	
	JP7	JP7.1	133	HSUSB_VDD12_CAP
		JP7.2	134	HSUSB_ID
		JP7.3	135	PE.7 / SD0_CMD / SPIM_D2 / UART5_TXD / CAN1_TXD / UART9_nCTS / EQEI1_INDEX / EPWM0_CH0 / BPWM0_CH5 / ACMP2_O / PSIO0_CH0
JP7.4		136	PE.6 / SD0_CLK / SPIM_D3 / SPI3_I2SMCLK / SC0_nCD / USCIO_CTL0 / UART5_RXD / CAN1_RXD / UART9_nRTS / EQEI1_A / EPWM0_CH1 / BPWM0_CH4 / ACMP3_O / PSIO0_CH1	
JP7.5		137	PE.5 / EBI_nRD / SD0_DAT3 / SPIM_SS / SPI3_SS / SC0_PWR / USCIO_CTL1 / UART6_TXD / UART7_nRTS / UART9_TXD / EQEI1_B / EPWM0_CH2 / BPWM0_CH3 / PSIO0_CH2	
JP7.6		138	PE.4 / EBI_nWR / SD0_DAT2 / SPIM_CLK / SPI3_CLK / SC0_RST / USCIO_DAT1 / UART6_RXD / UART7_nCTS / UART9_RXD / EQEI0_INDEX / EPWM0_CH3 / BPWM0_CH2 / PSIO0_CH3	
JP7.7		139	PE.3 / EBI_MCLK / SD0_DAT1 / SPIM_MISO / SPI3_MISO / SC0_DAT / USCIO_DAT0 / UART6_nRTS / UART7_TXD / UART8_nCTS / EQEI0_A / EPWM0_CH4 / BPWM0_CH1	
JP7.8		140	PE.2 / EBI_ALE / SD0_DAT0 / SPIM_MOSI / SPI3_MOSI / SC0_CLK / USCIO_CLK / UART6_nCTS / UART7_RXD / UART8_nRTS / EQEI0_B / EPWM0_CH5 / BPWM0_CH0	
JP7.9		141	V <sub>SS</sub>	
JP7.10		142	V <sub>DD</sub>	
JP7.11		143	PE.1 / EBI_AD10 / QSPI0_MISO0 / SC2_DAT / I2S0_BCLK / SPI1_MISO / UART3_TXD / I2C1_SCL / UART4_nCTS / UART8_TXD	
JP7.12		144	PE.0 / EBI_AD11 / QSPI0_MOSI0 / SC2_CLK / I2S0_MCLK / SPI1_MOSI / UART3_RXD / I2C1_SDA / UART4_nRTS / UART8_RXD	
JP7.13		145	PH.8 / EBI_AD12 / QSPI0_CLK / SC2_PWR / I2S0_DI / SPI1_CLK / UART3_nRTS / I2C1_SMBAL / I2C2_SCL / UART1_TXD / UART9_nCTS	
JP7.14		146	PH.9 / EBI_AD13 / QSPI0_SS / SC2_RST / I2S0_DO / SPI1_SS / UART3_nCTS / I2C1_SMBUS / I2C2_SDA / UART1_RXD / UART9_nRTS	
JP7.15		147	PH.10 / EBI_AD14 / QSPI0_MISO1 / SC2_nCD / I2S0_LRCK / SPI1_I2SMCLK / UART4_TXD / UART0_TXD / UART9_TXD	
JP7.16		148	PH.11 / EBI_AD15 / QSPI0_MOSI1 / UART4_RXD / UART0_RXD / EPWM0_CH5 / UART9_RXD	
JP7.17		149	PD.14 / EBI_nCS0 / SPI3_I2SMCLK / SC1_nCD / SPI0_I2SMCLK / I2S1_BCLK / EPWM0_CH4	
JP7.18		150	PJ.8 / EBI_nRD / SD1_DAT3 / SPIM_SS / UART7_TXD / CAN2_TXD / BPWM0_CH5	
JP7.19		151	PJ.9 / EBI_nWR / SD1_DAT2 / SPIM_MISO / UART7_RXD / CAN2_RXD / BPWM0_CH4	
JP7.20		152	PJ.10 / EBI_MCLK / SD1_DAT1 / SPIM_D2 / UART6_TXD / I2C4_SCL / ECAP2_IC0 / CAN0_TXD / BPWM0_CH3	
JP7.21		153	PJ.11 / EBI_ALE / SD1_DAT0 / SPIM_D3 / UART6_RXD / I2C4_SDA / ECAP2_IC1 / CAN0_RXD / BPWM0_CH2	

Header	M467HJHAN	
	Pin No.	Function
JP7.22	154	PJ.12 / EBI_nCS0 / SD1_CMD / SPIM_CLK / I2C4_SMBAL / ECAP2_IC2 / CAN1_TXD / BPWM0_CH1 / HSUSB_VBUS_ST
JP7.23	155	PJ.13 / SD1_CLK / SPIM_MOSI / I2C4_SMBSUS / CAN1_RXD / BPWM0_CH0 / HSUSB_VBUS_EN
JP7.24	156	PG.5 / EBI_nCS1 / SPI3_SS / SC1_PWR / I2C3_SMBAL / I2S1_MCLK / EPWM0_CH3
JP7.25	157	PG.6 / EBI_nCS2 / SPI3_CLK / SC1_RST / I2C3_SMBSUS / I2S1_DI / EPWM0_CH2
JP7.26	158	PG.7 / EBI_nWRL / SPI3_MISO / SC1_DAT / I2C3_SCL / I2S1_DO / EPWM0_CH1
JP7.27	159	PG.8 / EBI_nWRH / SPI3_MOSI / SC1_CLK / I2C3_SDA / I2S1_LRCK / EPWM0_CH0
JP7.28	160	V <sub>SS</sub>
JP7.29	161	LDO_CAP
JP7.30	162	V <sub>DD</sub>
JP7.31	163	PC.14 / EBI_AD11 / SC1_nCD / SPI0_I2SMCLK / USCIO_CTL0 / QSPI0_CLK / TRACE_SWO / EPWM0_SYNC_IN / ETMC_TRACE_CLK / TM1 / USB_VBUS_ST / HSUSB_VBUS_ST
JP7.32	164	PB.15 / EADC0_CH15 / EADC1_CH15 / EBI_AD12 / SC1_PWR / SPI0_SS / USCIO_CTL1 / UART0_nCTS / UART3_TXD / I2C2_SMBAL / CCAP_DATA1 / EPWM0_BRAKE1 / EPWM1_CH0 / ETMC_TRACE_DATA0 / TM0_EXT / USB_VBUS_EN / HSUSB_VBUS_EN / PSIO0_CH0 / KPI_COL0
JP7.33	165	PB.14 / EADC0_CH14 / EADC1_CH14 / EBI_AD13 / SC1_RST / SPI0_CLK / USCIO_DAT1 / UART0_nRTS / UART3_RXD / I2C2_SMBSUS / CCAP_DATA0 / EPWM1_CH1 / ETMC_TRACE_DATA1 / TM1_EXT / CLKO / USB_VBUS_ST / PSIO0_CH1 / KPI_COL1
JP7.34	166	PB.13 / EADC0_CH13 / EADC1_CH13 / DAC1_OUT / ACMP0_P3 / ACMP1_P3 / EBI_AD14 / SC1_DAT / SPI0_MISO / USCIO_DAT0 / UART0_TXD / UART3_nRTS / I2C2_SCL / CCAP_PIXCLK / EPWM1_CH2 / ETMC_TRACE_DATA2 / TM2_EXT / CAN3_TXD / PSIO0_CH2 / KPI_COL2
JP7.35	167	PB.12 / EADC0_CH12 / EADC1_CH12 / DAC0_OUT / ACMP0_P2 / ACMP1_P2 / EBI_AD15 / SC1_CLK / SPI0_MOSI / USCIO_CLK / UART0_RXD / UART3_nCTS / I2C2_SDA / SD0_nCD / CCAP_SCLK / EPWM1_CH3 / ETMC_TRACE_DATA3 / TM3_EXT / CAN3_RXD / PSIO0_CH3 / KPI_COL3
JP7.36	168	AV <sub>DD</sub>
JP7.37	169	V <sub>REF</sub>
JP7.38	170	AV <sub>SS</sub>
JP7.39	171	PB.11 / EADC0_CH11 / EBI_ADR16 / EMAC0_RMII_MDC / UART0_nCTS / UART4_TXD / I2C1_SCL / CAN0_TXD / SPI0_I2SMCLK / BPWM1_CH0 / SPI3_CLK / CCAP_SFIELD / HSUSB_VBUS_ST
JP7.40	172	PB.10 / EADC0_CH10 / ACMP2_P3 / EBI_ADR17 / EMAC0_RMII_MDIO / UART0_nRTS / UART4_RXD / I2C1_SDA / CAN0_RXD / BPWM1_CH1 / SPI3_SS / CCAP_VSYNC / HSUSB_VBUS_EN
JP7.41	173	PB.9 / EADC0_CH9 / ACMP2_P2 / EBI_ADR18 / EMAC0_RMII_TXD0 / UART0_TXD / UART1_nCTS / I2C1_SMBAL / UART7_TXD / I2C0_SCL / BPWM1_CH2 / SPI3_MISO / CAN2_TXD / INT7 / CCAP_HSYNC
JP7.42	174	PB.8 / EADC0_CH8 / ACMP2_P1 / EBI_ADR19 / EMAC0_RMII_TXD1 / UART0_RXD / UART1_nRTS / I2C1_SMBSUS / UART7_RXD / I2C0_SDA / BPWM1_CH3 / SPI3_MOSI / CAN2_RXD / INT6 / EADC2_ST
JP7.43	175	PB.7 / EADC0_CH7 / EADC2_CH15 / ACMP2_P0 / EBI_nWRL / EMAC0_RMII_TXEN / CAN1_TXD / UART1_TXD / SD1_CMD / EBI_nCS0 / BPWM1_CH4 / EPWM1_BRAKE0 / EPWM1_CH4 / INT5 / USB_VBUS_ST / ACMP0_O / KPI_COL4
JP7.44	176	PB.6 / EADC0_CH6 / EADC2_CH14 / ACMP2_N / EBI_nWRH / EMAC0_PPS / CAN1_RXD / UART1_RXD / SD1_CLK / EBI_nCS1 / BPWM1_CH5 / EPWM1_BRAKE1 / EPWM1_CH5 / INT4 / USB_VBUS_EN / ACMP1_O / KPI_COL5

Table 3-2 M467HJHAN Full-pin Extension Connectors and GPIO Function List

### 3.3.2 Arduino UNO Compatible Extension Connectors

Figure 3-4 shows the Arduino UNO compatible extension connectors.

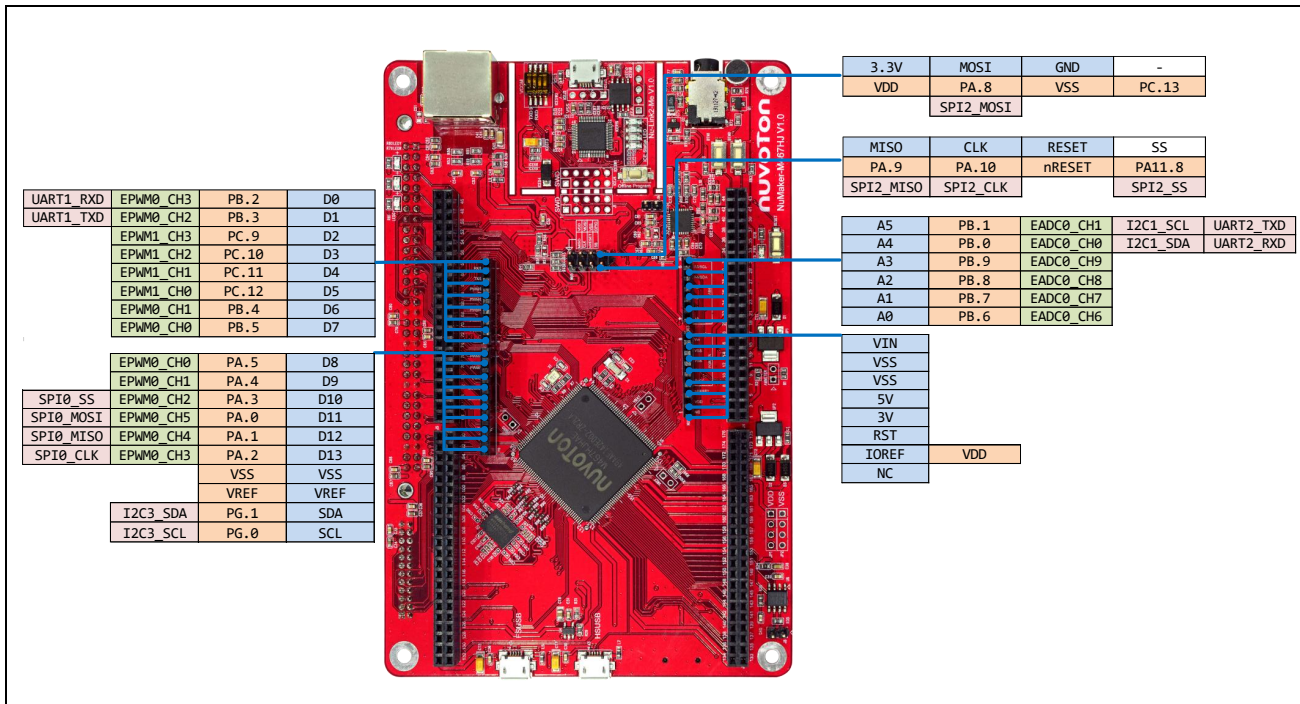

Figure 3-4 Arduino UNO Compatible Extension Connectors

Header		NuMaker-M467HJ		Header		NuMaker-M467HJ	
		Compatible to Arduino UNO	GPIO Pin of M467			Compatible to Arduino UNO	GPIO Pin of M467
NU4	NU4.1	D0	PB.2	NU3	NU3.6	A5	PB.6
	NU4.2	D1	PB.3		NU3.5	A4	PB.7
	NU4.3	D2	PC.9		NU3.4	A3	PB.8
	NU4.4	D3	PC.10		NU3.3	A2	PB.9
	NU4.5	D4	PC.11		NU3.2	A1	PB.0
	NU4.6	D5	PC.12		NU3.1	A0	PB.1
	NU4.7	D6	PB.4	NU1	NU1.8	VIN	-
	NU4.8	D7	PB.5		NU1.7	VSS	
NU2	NU2.1	D8	PA.5		NU1.6	VSS	
	NU2.2	D9	PA.4		NU1.5	5V	
	NU2.3	D10	PA.3		NU1.4	3V	
	NU2.4	D11	PA.0		NU1.3	RST	nRESET
	NU2.5	D12	PA.1		NU1.2	IOREF	V <sub>REF</sub>
	NU2.6	D13	PA.2		NU1.1	NC	-
	NU2.7	VSS	V <sub>SS</sub>				
	NU2.8	VREF	V <sub>REF</sub>				
	NU2.9	SDA	PG.0				
	NU2.10	SCL	PG.1				

Table 3-3 Arduino UNO Extension Connectors and M467HJHAN Mapping GPIO List

### 3.4 Power Supply Configuration

The NuMaker-M467HJ is able to adopt multiple power supplies. External power sources include NU1 Vin (7 V to 12 V), V<sub>DD</sub> (depending on the target chip operating voltage), and PC through USB connector. By using switches and voltage regulator, multiple power domains can be created on the NuMaker-M467HJ.

#### 3.4.1 VIN Power Source

Table 3-4 presents the Vin power source.

Connector	Net Name in Schematic	Description
NU1 pin8	NU1_VIN	Board external power source, with voltage range from 7 V to 12 V. The voltage regulator UP1 converts the NU1 pin8 input voltage to 5 V and supplies it to NU1_5VCC.

Table 3-4 Vin Power Source

#### 3.4.2 5V Power Sources

Table 3-5 presents the 5 V power sources.

Connector	Net Name in Schematic	Description
ICEJ3	USB_HS_VBUS	ICE USB connector supplies 5 V power from PC to M467HJ target board and Nu-Link2-Me.
J2	USB_VBUS	FS USB connector on NuMaker-M467HJ supplies 5 V power from PC to M467HJ target board and Nu-Link2-Me.
J3	HSUSB_VBUS	HS USB connector on NuMaker-M467HJ supplies 5 V power from PC to M467HJ target board and Nu-Link2-Me.
NU1 pin5	UNO_5V	ICEJ3, J2, J3 or NU1 pin8 supplies 5V power to NU1 pin5. NU1 pin5 supplies 5V power to target chip or Arduino adapter board.

Table 3-5 5V Power Sources

3.4.3 3.3V Power Sources

Table 3-6 presents the 3.3 V power sources.

Voltage Regulator	3V Source	Description
ICEUP1	USB_HS_VBUS	ICEUP1 converts USB_HS_VBUS to 3.3 V and supplies 3.3 V to M467HJ target board or ICE chip.
UP2	FSUSB_VBUS	UP2 converts FSUSB_VBUS to 3.3 V and supplies 3.3 V to M467HJ target board.
UP2	HSUSB_VBUS	UP2 converts HSUSB_VBUS to 3.3 V and supplies 3.3 V to M467HJ target board.
UP2	UNO_5VCC	UP1 converts NU1_5VCC to 3.3 V and supplies 3.3 V to M467HJ target board. <b>Note:</b> SW2.2 (NU1 3VCC) should be switched to ON.

Table 3-6 3.3 V Power Sources

3.4.4 Power Connectors

Table 3-7 presents the power connectors.

Connector	Description
JP1	V <sub>DD</sub> connector on the NuMaker-M467HJ. <b>Note:</b> M467 operating voltage range is from 1.8 V to 3.6 V.
JP2	V <sub>SS</sub> connector on the NuMaker-M467HJ.

Table 3-7 Power Connectors



### 3.4.5 USB Connectors

Table 3-8 presents the USB connectors.

Connector	Description
ICEJ3	ICE USB connector on Nu-Link2-Me for power supply, debugging and programming from PC.
J2	USB FS connector on NuMaker-M467HJ for power supply.
J3	USB HS connector on NuMaker-M467HJ for power supply.

Table 3-8 USB Connectors

### 3.4.6 Power Switches

Table 3-9 presents the power switches.

Switch	Description
ICEJPR1	Configures the target chip operating voltage at 1.8 V / 3.3 V / 5 V. <b>Note:</b> M467 operating voltage range is from 1.8 V to 3.6 V. Do not switch ICEJPR1 (MCUVCC) to 5 V.
ICEJPR2	Configures the ICE chip operating voltage at 1.8 V / 3.3 V.

Table 3-9 Power Switches

### 3.4.7 Power Supply Models

#### 3.4.7.1 External Power Supply through Nu-Link2-Me to Target Chip

The external power supply source on Nu-Link2-Me is shown in Figure 3-5.

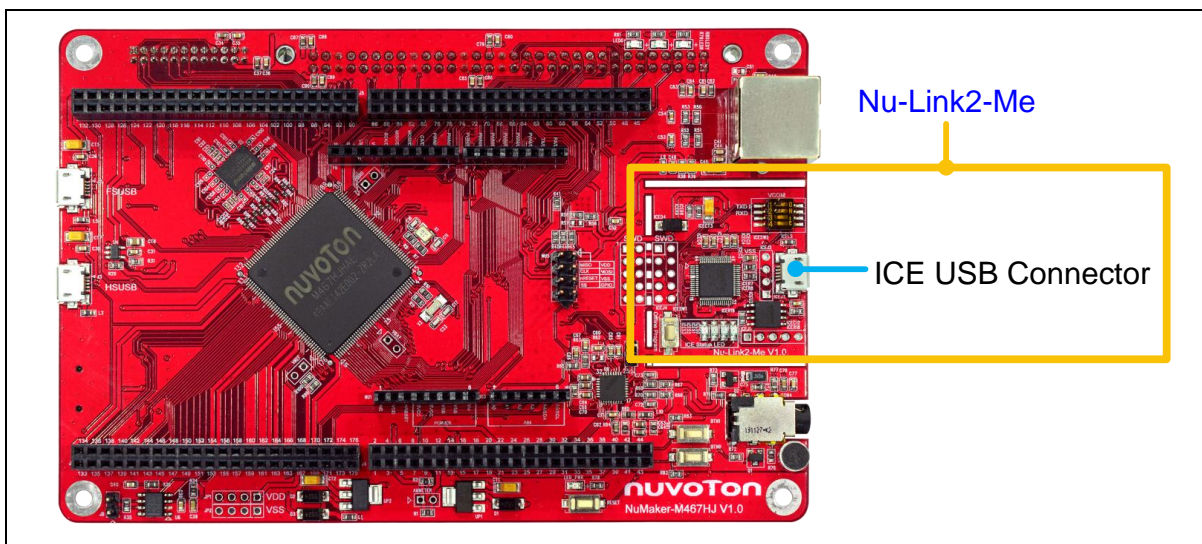

Figure 3-5 External Power Supply Sources on Nu-Link2-Me

To use ICEJ3 as external power supply source with Nu-Link2-Me, please follow the steps below:

1. Solder the resistor on ICEJPR1 (MCUVCC) depending on the target chip operating voltage.
2. Solder the resistor on ICEJPR2 (ICEVCC) depending on the ICE chip operating voltage.
3. Connect the external power supply to ICEJ3.

Table 3-10 presents all power models when supplying external power through Nu-Link2-Me. The Nu-Link2-Me external power sources are highlighted in yellow.

Model	Target Chip Voltage	ICEJ3	ICEJPR1 (MCUVCC) Selection <sup>[1]</sup>	ICEJPR2 (ICEVCC) Selection <sup>[2]</sup>	ICE Chip Voltage	SW2 Selection	J2	Vin	JP1
1	1.8 V	Connect to PC	1.8 V	1.8 V	1.8 V	Off	-	-	1.8 V output
2	3.3 V	Connect to PC	3.3 V (default)	3.3 V (default)	3.3 V	Off	-	-	3.3 V output
3	5 V	Connect to PC	5 V	3.3 V (default)	3.3 V	Off	-	-	5 V output
<p><b>Note:</b></p> <ol style="list-style-type: none"> <li>1. 0 Ω should be soldered between ICEJPR1's MCVCC and 1.8 V / 3.3 V / 5 V.</li> <li>2. 0 Ω should be soldered between ICEJPR2's ICEVCC and 1.8 V / 3.3 V.</li> <li>3. -: Unused.</li> </ol>									

Table 3-10 Supply External Power through Nu-Link2-Me

3.4.7.2 External Power Supply through M467HJ Target Board to Target Chip

The external power supply sources on M467HJ target board are shown in Figure 3-6.

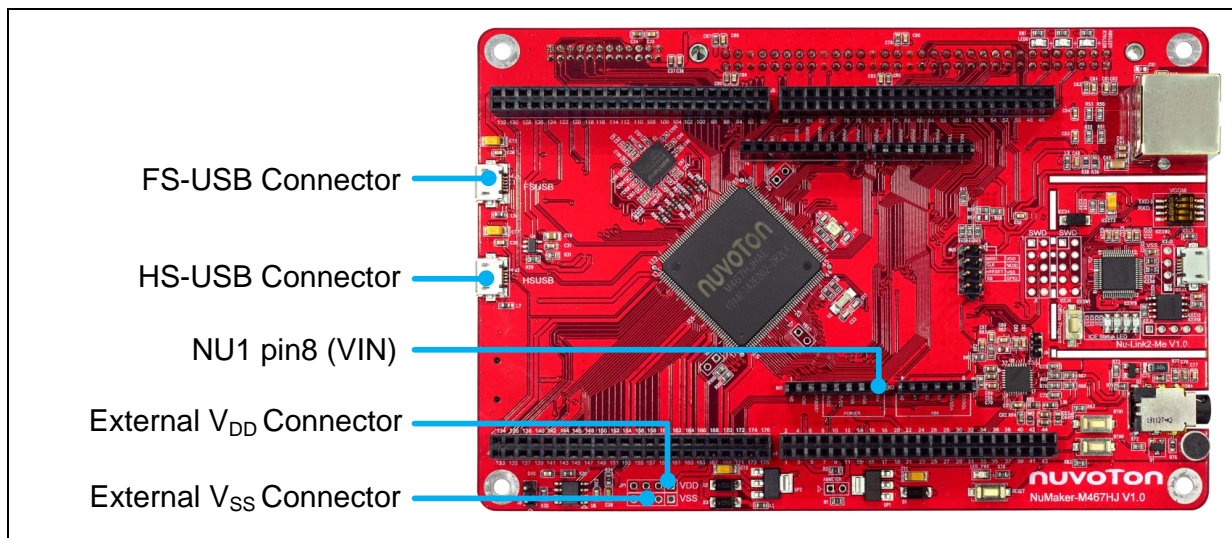

Figure 3-6 External Power Supply Sources on M467HJ Target Board

To use Vin or J2 or J3 as external power supply source, please follow the steps below:

1. Remove the resistor on ICEJPR1 (MCUVCC).
2. Solder the resistor on ICEJPR2 (ICEVCC) depending on the ICE chip operating voltage.
3. Connect the external power supply to Vin or J2 or J3.

To use JP1 as external power supply source, please follow the steps below:

1. Remove the resistor on ICEJPR1 (MCUVCC).
2. Solder the resistor on ICEJPR2 (ICEVCC) depending on the ICE chip operating voltage.
3. Connect ICEJ3 to PC.
4. Connect the external power supply to JP1.

To use Vin or J2 or J3 as external power supply source with Nu-Link2-Me detached from NuMaker-M467HJ, please follow the steps below:

1. Detach the Nu-Link2-Me from NuMaker- M467HJ.
2. Connect the external power supply to Vin or J2 or J3.

To use JP1 as external power supply source with Nu-Link2-Me detached from NuMaker- M467HJ, please follow the steps below:

1. Detach the Nu-Link2-Me from NuMaker-M467HJ.
2. Connect the external power supply to JP1.

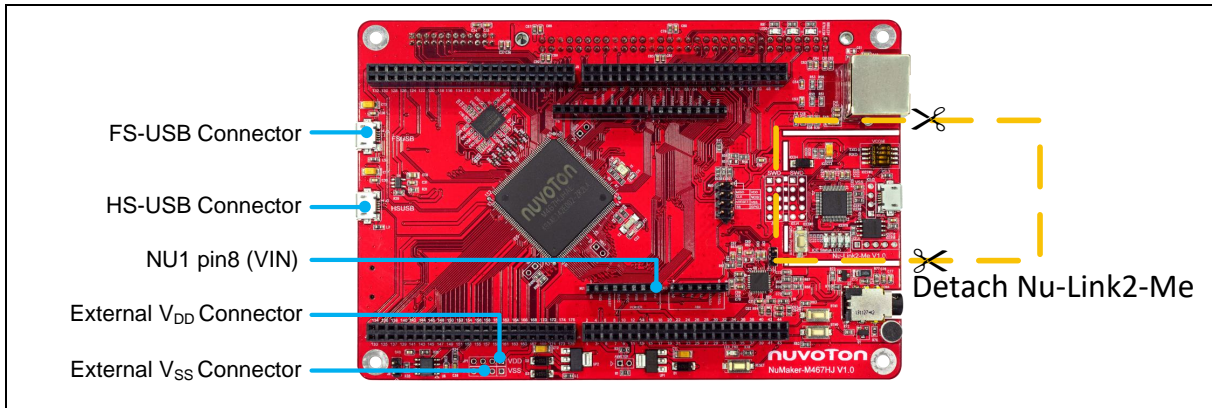

Figure 3-7 Detach the Nu-Link2-Me from NuMaker-M467HJ

Table 3-11 presents all power models when supplies external power through M467HJ target board. The M467HJ target board external power sources are highlighted in yellow.

Model	Target Chip Voltage	Vin <sup>[1]</sup>	J2 <sup>[1]</sup>	J3 <sup>[1]</sup>	ICEJ3	JP1 <sup>[2]</sup>	ICEJPR1 (MCUVCC) Selection <sup>[3]</sup>	ICEJPR2 (ICEVCC) Selection <sup>[4]</sup>	ICE Chip Voltage <sup>[5]</sup>
4	3.3 V	7 V ~ 12 V Input	-	-	-	3.3 V output	Remove resistor	3.3 V	3.3 V
5	3.3 V	-	Connect to PC	-	-	3.3 V output	Remove resistor	3.3 V	3.3 V
6	3.3V	-	-	Connect to PC	-	3.3 V output	Remove resistor	3.3 V	3.3 V
7	1.8 V ~ 3.6 V	-	-	-	Connect to PC	DC Input 1.8 V ~ 3.6 V	Remove resistor	1.8 V / 3.3 V	1.8 V / 3.3 V
8	1.8 V ~ 3.6 V	-	-	-	Nu-Link2-Me removed	DC Input 1.8 V ~ 3.6 V	-	-	-

**Note:**

1. The Vin input voltage will be converted by voltage regulator UP2 to 5 V. Supplying external power to Vin or J2 or J3 can provide 5 V to NU1 pin5 (5V) and 3.3 V to NU1 pin4 (3VCC).
2. JP1 external power input only provides voltage to target chip.
3. 0 Ω should be removed from ICEJPR1's MCVCC and 1.8 V / 3.3 V / 5 V.
4. 0 Ω should be soldered between ICEJPR2's ICEVCC and 1.8 V / 3.3 V.
5. The ICE chip voltage should be close to the target chip voltage.
6. -: Unused

Table 3-11 Supply External Power for M467HJ Target Board



### 3.5 External Reference Voltage Connector

Table 3-13 presents the external reference voltage connector.

Connector	Description
VREF	Connector for user to connect to the external reference voltage pin of the target chip. User needs to remove the L2 ferrite bead.

Table 3-12 External Reference Voltage Connector

### 3.6 Ammeter Connector

Table 3-13 presents the ammeter connector.

Connector	Description
AMMETER	Connector for user to measure the target chip power consumption easily. User needs to remove the R1 resistor.

Table 3-13 Ammeter Connector

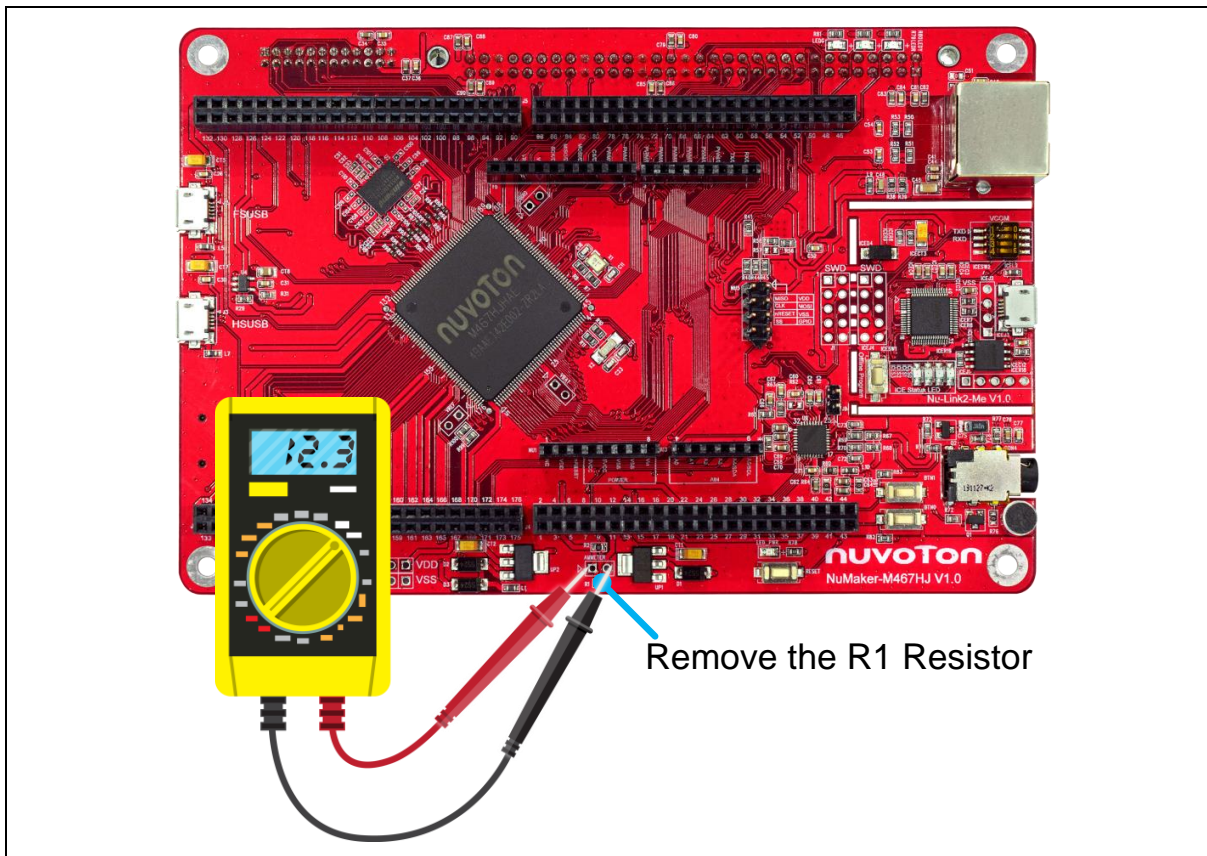

Figure 3-8 Wiring between Ammeter Connector and Ammeter

**3.7 Push Buttons**

Table 3-14 presents the push buttons.

<b>Component</b>	<b>Description</b>
ICESW1	Offline program button to start offline ICP programming the target chip.
SW1	Reset button to reset the target chip.

Table 3-14 Push Buttons



### 3.8 LEDs

Table 3-15 presents the LEDs.

Component	Description
Power LED	The power LED indicates that the NuMaker-M467HJ is powered.
Red LED	The red LED is connected to the target chip PH.4.
Yellow LED	The yellow LED is connected to the target chip PH.5.
Green LED	The green LED is connected to the target chip PH.6.
ICES0, ICES1, ICES2 and ICES3	Nu-Link2-Me status LED.

Table 3-15 LEDs

### 3.9 Nu-Link2-Me

The Nu-Link2-Me is an attached on-board debugger and programmer. The Nu-Link2-Me supports on-chip debugging, online and offline ICP programming through SWD interface. The Nu-Link2-Me also supports virtual COM port (VCOM) for printing debug messages on PC. Besides, the programming status could be shown on the built-in LEDs. Lastly, the Nu-Link2-Me could be detached from the evaluation board and become a stand-alone mass production programmer. For more information about Nu-Link2-Me, please refer to *Nu-Link2-Pro Debugger and Programmer User Manual*.

#### 3.9.1 VCOM Switches

Table 3-16 presents how to set the VCOM function by ICESW2.

ICESW2		
Pin	Function	Description
1	TXD	<b>On:</b> Connect target chip PB.13 (UART0_TXD) to Nu-Link2-Me. <b>Off:</b> Disconnect target chip PB.13 (UART0_TXD) to Nu-Link2-Me.
2	RXD	<b>On:</b> Connect target chip PB.12 (UART0_RXD) to Nu-Link2-Me. <b>Off:</b> Disconnect target chip PB.12 (UART0_RXD) to Nu-Link2-Me.
<b>Note:</b> Pin 3 and 4 is unused.		

Table 3-16 VCOM Function of Nu-Link2-Me

3.9.2 Status LEDs

Table 3-15 presents the status LEDs patterns for different operation on Nu-Link2-Me.

Operation Status	Status LED			
	ICES0	ICES1	ICES2	ICES3
Boot	Flash x 3	Flash x 3	Flash x 3	Flash x 3
Idle	On	-	-	-
One Nu-Link2-Me is selected to connect	Flash x 3	Flash x 3	Flash x 3	On
ICE online (Not connected to a target chip)	On	-	Flash x 3	Flash x 3
ICE online (Connected to a target chip)	On	-	-	On
ICE online (Failed to connect to a target chip)	On	Any	Flash	On
During offline programming	-	On	-	Flash
Offline programming completed	On	-	-	-
Offline programming completed (Auto mode)	On	On	-	-
Offline programming failed	On	Flash	-	-
<b>Note:</b> "Online" means Nu-Link2-Me is connected to ICP Programming Tool, IDE or NuTool.				

Table 3-17 Operation Status LED Patterns

## 4 QUICK START

### 4.1 Toolchains Supporting

Install the preferred toolchain. Please make sure at least one of the toolchains has been installed.

- [KEIL MDK Nuvoton edition](#)
- [IAR EWARM](#)
- [NuEclipse GCC \(for Windows\)](#)
- [NuEclipse GCC \(for Linux\)](#)

### 4.2 Nuvoton Nu-Link Driver Installation

Download and install the latest Nuvoton Nu-Link Driver.

- Download and install [Nu-Link Keil Driver](#) when using Keil MDK.
- Download and install [Nu-Link IAR Driver](#) when using IAR EWARM.
- Skip this step when using NuEclipse.

Please install the Nu-Link USB Driver as well at the end of the installation. The installation is presented in Figure 4-1 and Figure 4-2.

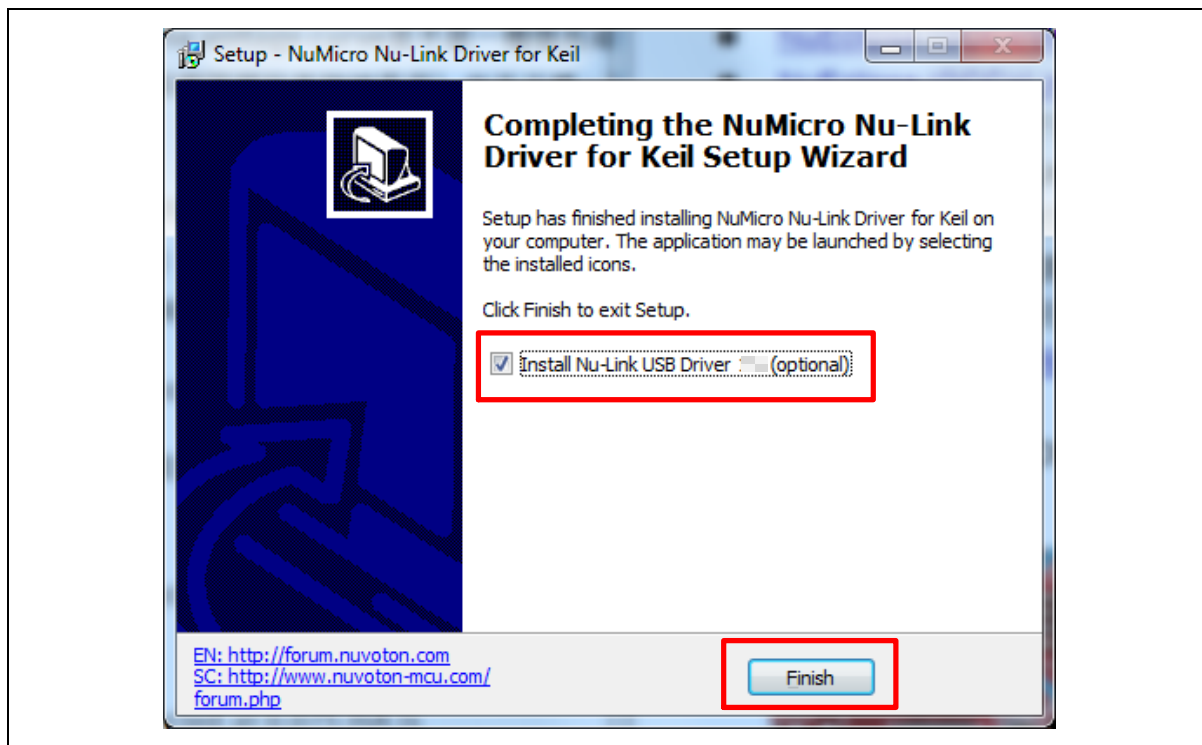

Figure 4-1 Nu-Link USB Driver Installation Setup

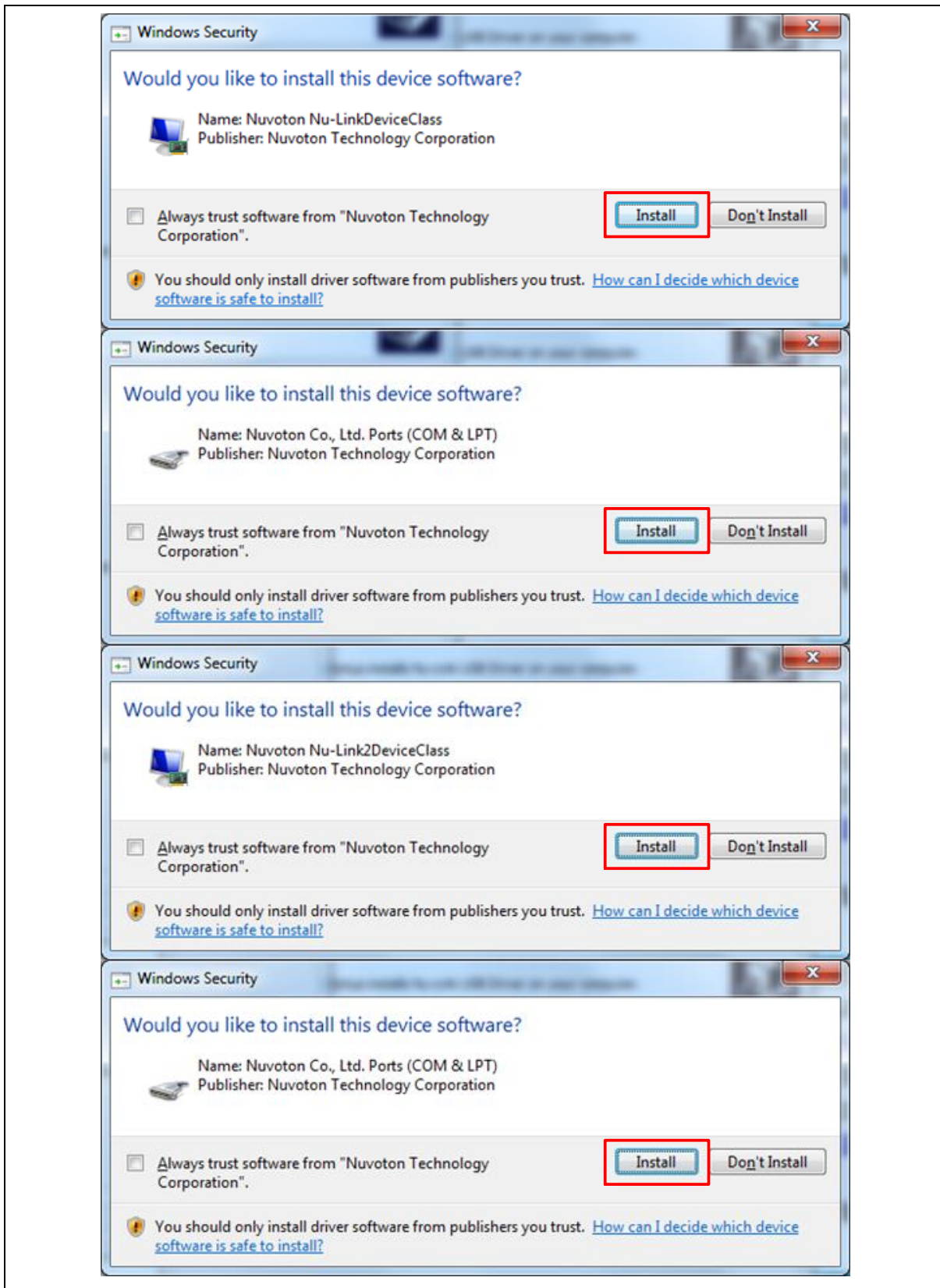

Figure 4-2 Nu-Link USB Driver Installation

### 4.3 BSP Firmware Download

Download and unzip the [Board Support Package \(BSP\)](#).

### 4.4 Hardware Setup

1. Open the virtual COM (VCOM) function by changing Nu-Link2-Me VCOM Switch No. 1 and 2 to ON.

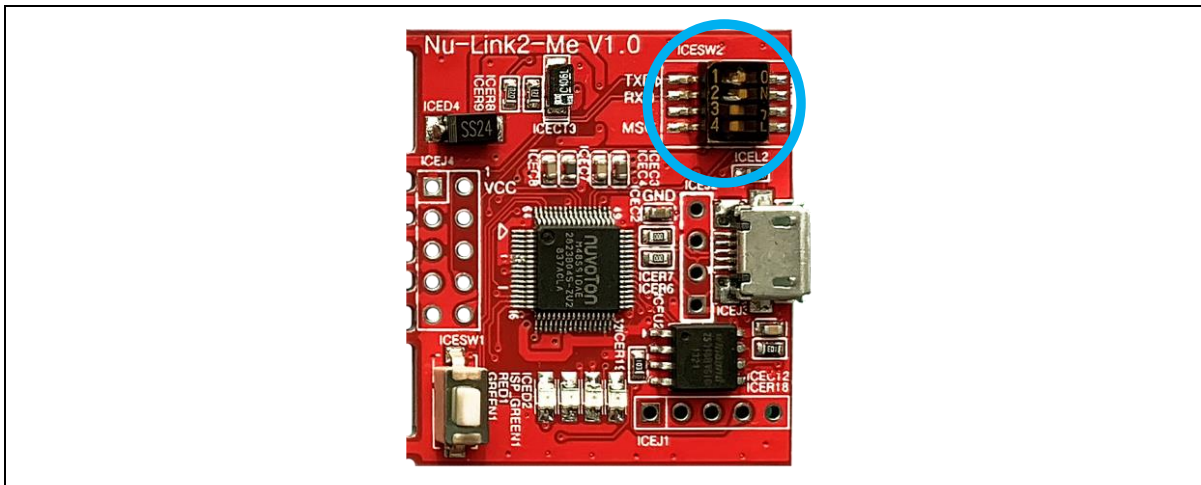

Figure 4-3 Open VCOM Function

2. Connect the ICE USB connector shown in Figure 4-4 to the PC USB port through a USB cable.

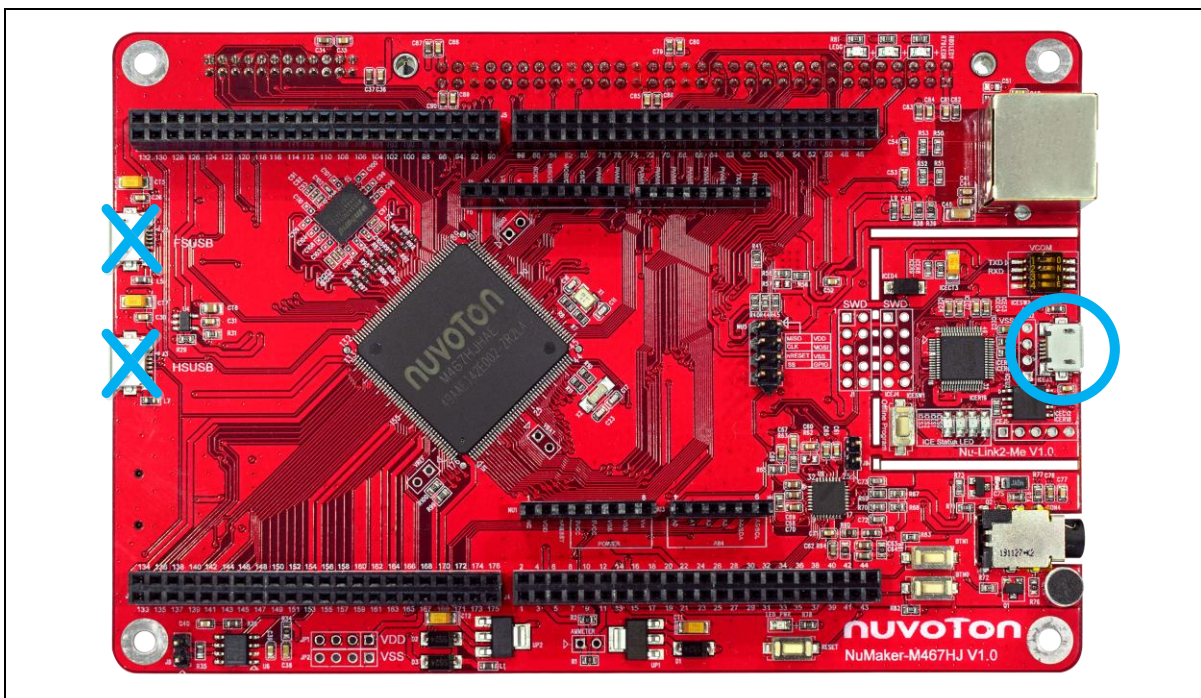

Figure 4-4 ICE USB Connector



3. Find the “Nuvoton Virtual COM Port” on the Device Manger as Figure 4-5.

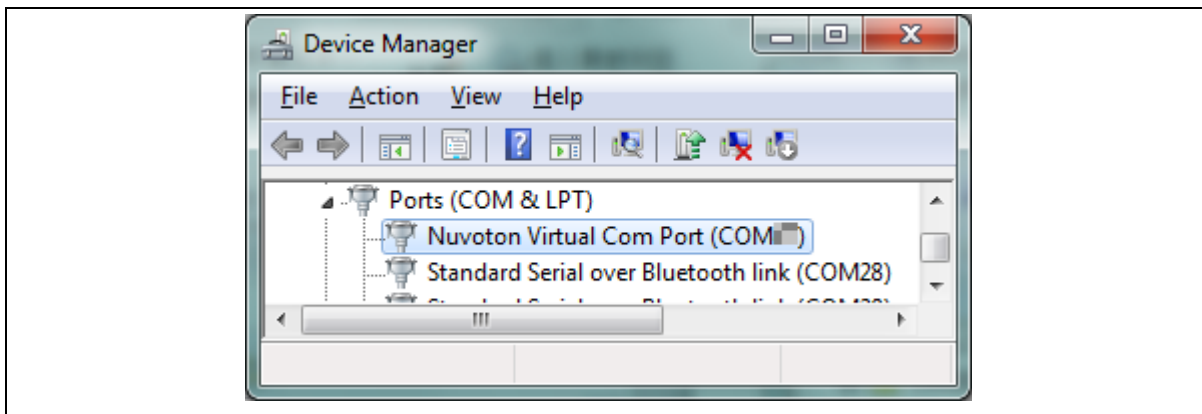

Figure 4-5 Device Manger

4. Open a serial port terminal, PuTTY for example, to print out debug message. Set the speed to 115200. Figure 4-6 presents the PuTTY session setting.

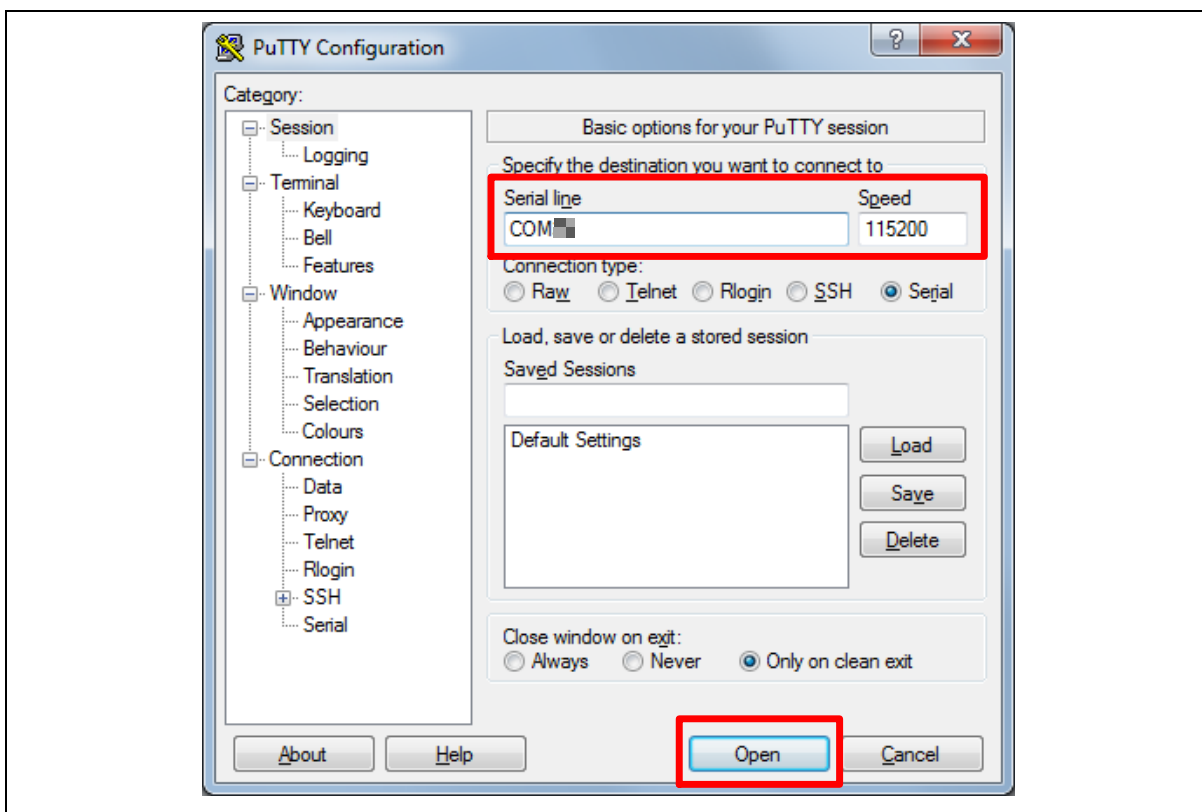

Figure 4-6 PuTTY Session Setting

#### 4.5 Find the Example Project

Use the “Template” project as an example. The project can be found under the BSP folder as shown in Figure 4-7.

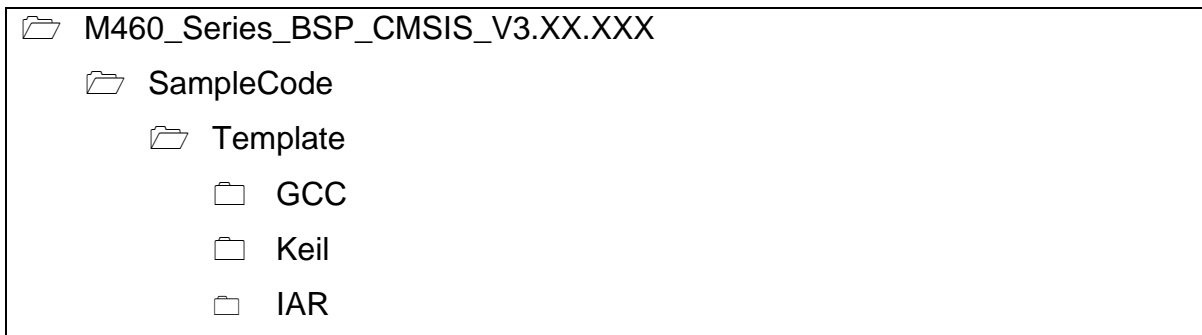

Figure 4-7 Template Project Folder Path

#### 4.6 Execute the Project under Toolchains

Open and execute the project under the toolchain. The section 4.6.1, 4.6.2, and 4.6.3 describe the steps of executing project in Keil MDK, IAR EWARM and NuEclipse, respectively.

##### 4.6.1 Keil MDK

This section provides steps to beginners on how to run a project by using Keil MDK.

1. Double-click the “Template.uvproj” to open the project.

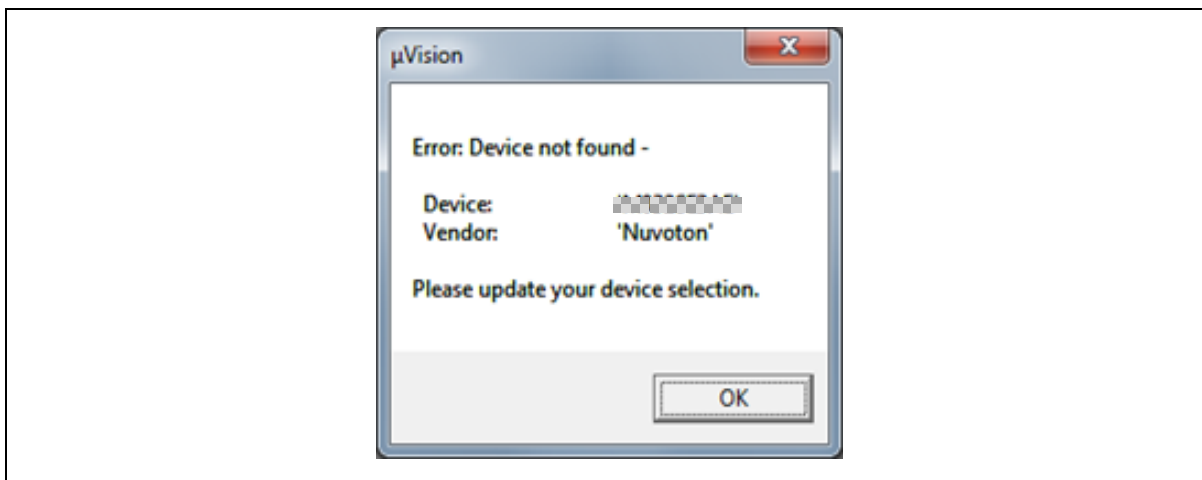

Figure 4-8 Warning Message of “Device not found”

**Note:** If Figure 4-8 warning message jumps out, please migrate to version 5 format as shown in Figure 4-9. The “.uvproj” filename extension will change to “.uvprojx”.



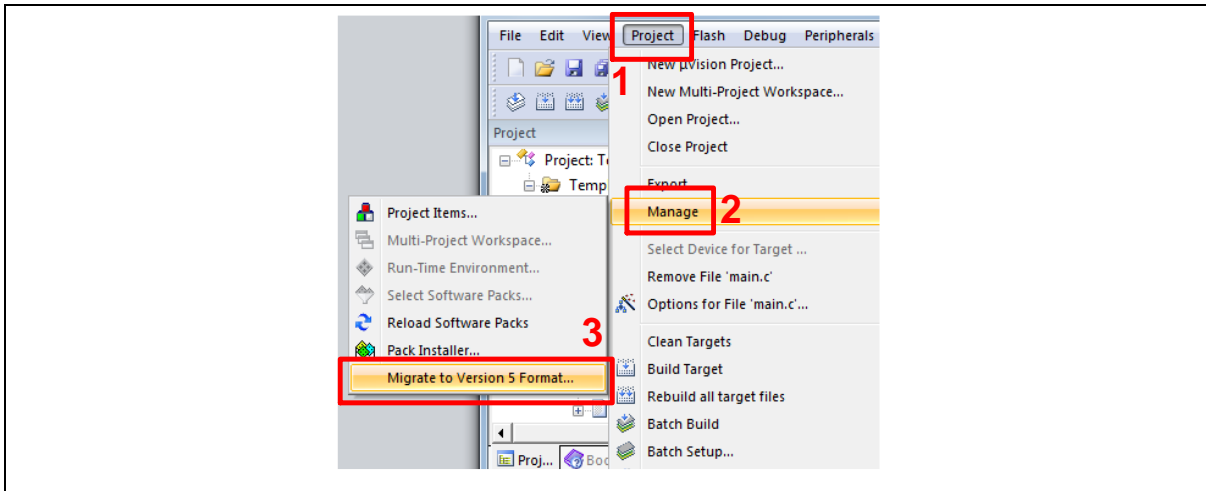

Figure 4-9 Project File Migrate to Version 5 Format

2. Make sure the debugger is “Nuvoton Nu-Link Debugger” as shown in Figure 4-10 and Figure 4-11.

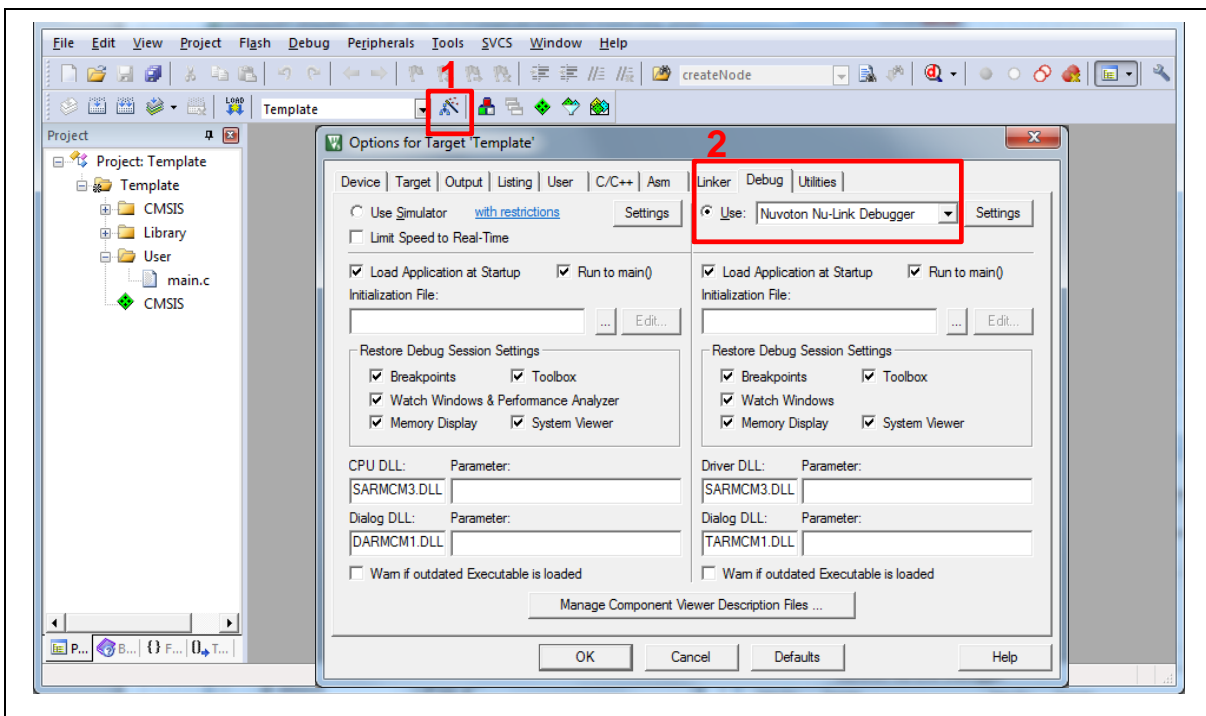

Figure 4-10 Debugger Setting in Options Window

**Note:** If the dropdown menu in Figure 4-10 does not contain “Nuvoton Nu-Link Debugger” item, please rework section 4.2.

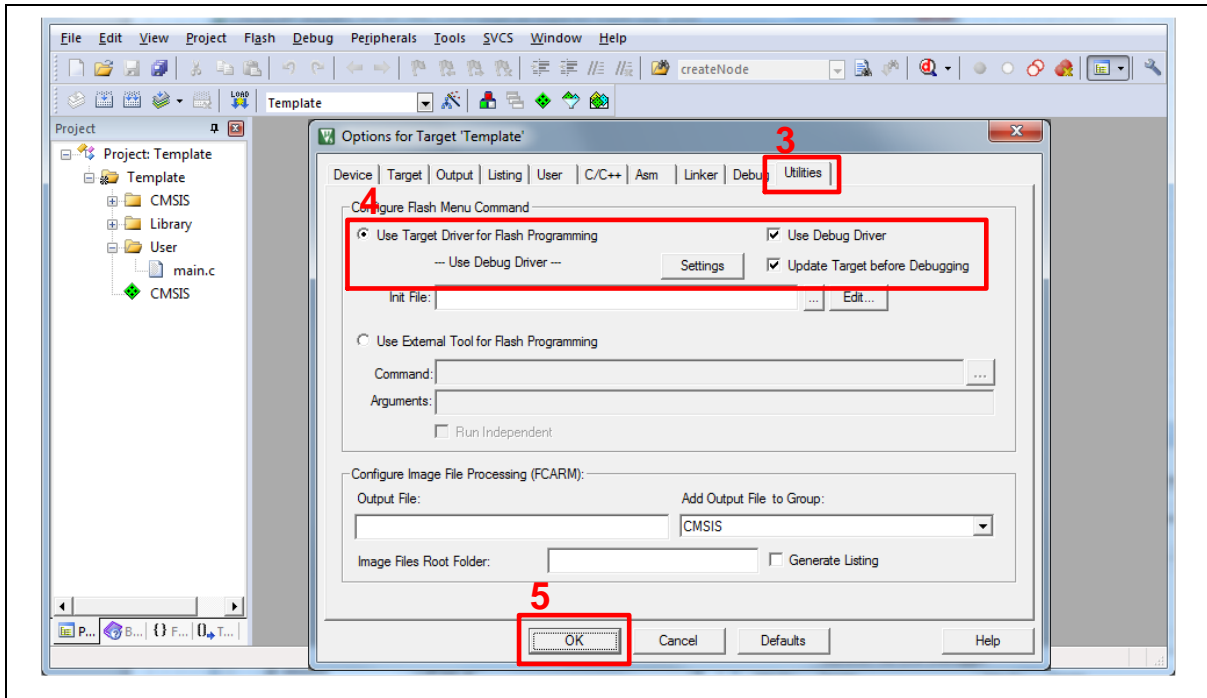

Figure 4-11 Programming Setting in Options Window

3. Rebuild all target files. After successfully compiling the project, download code to the Flash memory. Click **“Start/Stop Debug Section”** button to enter debug mode.

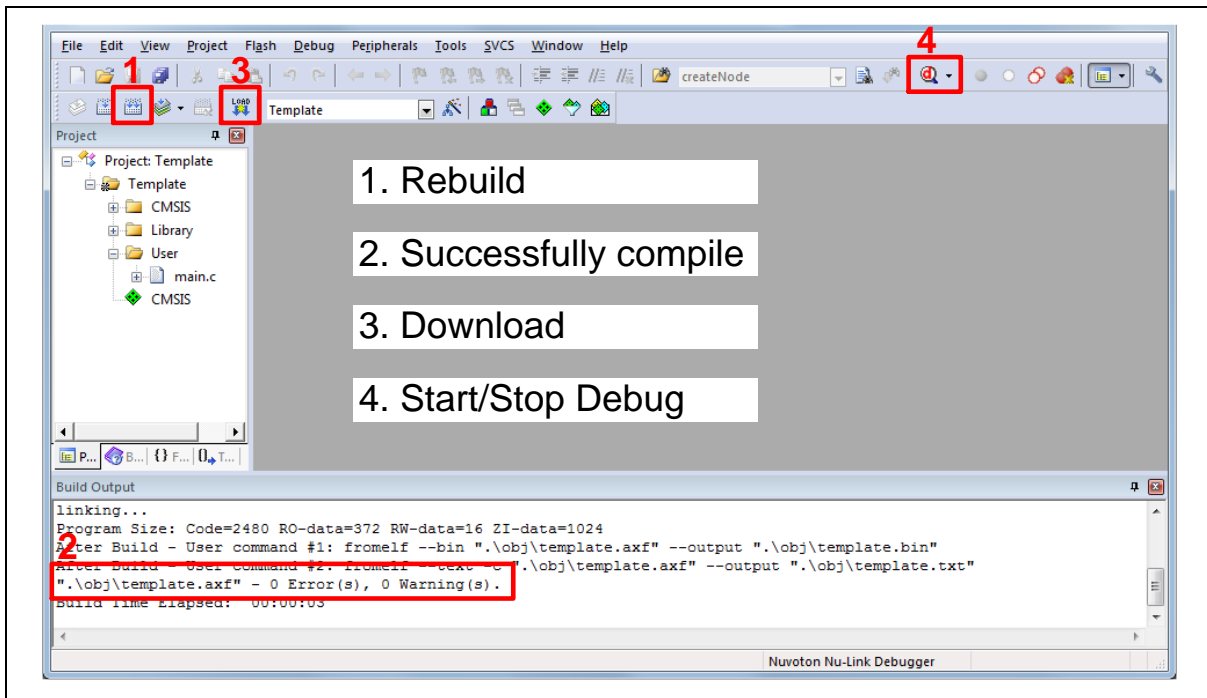

Figure 4-12 Compile and Download the Project

4. Figure 4-13 shows the debug mode under Keil MDK. Click “Run” and the debug message will be printed out as shown in Figure 4-14. User can debug the project under debug mode by checking source code, assembly language, peripherals’ registers, and setting breakpoint, step run, value monitor, etc.

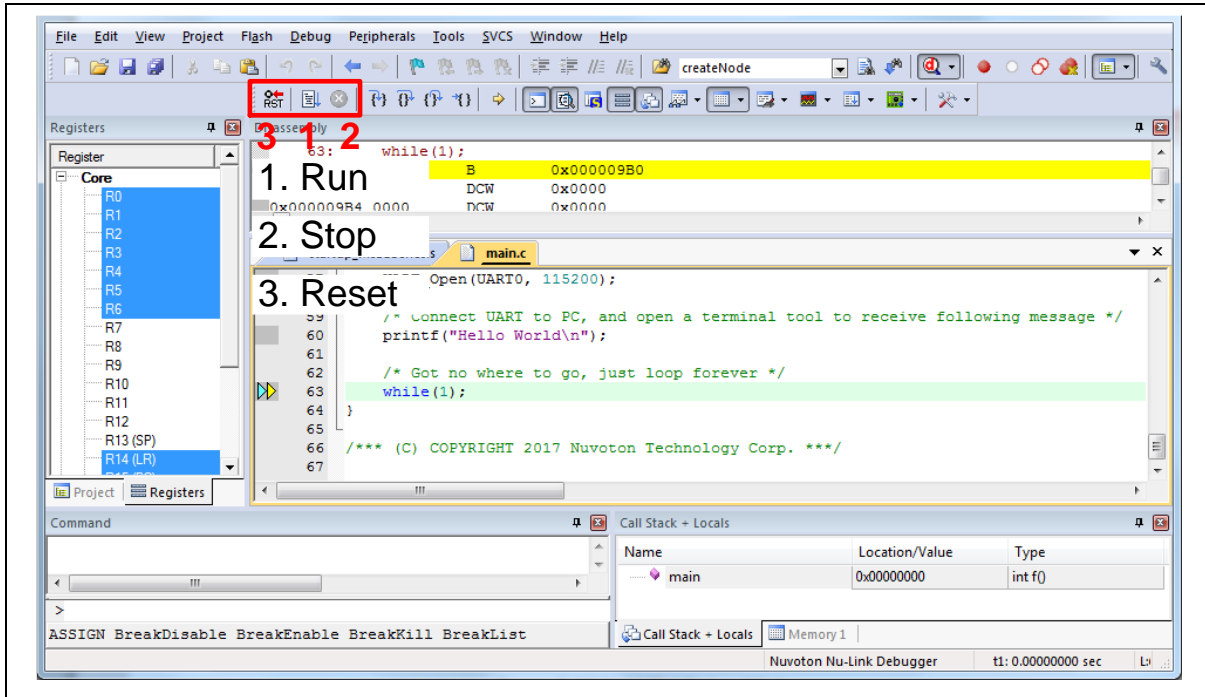

Figure 4-13 Keil MDK Debug Mode



Figure 4-14 Debug Message on Serial Port Terminal Windows

4.6.2 IAR EWARM

This section provides steps to beginners on how to run a project by using IAR EWARM.

1. Double click the “Template.eww” to open the project.
2. Make sure the toolbar contains “Nu-Link” item as shown in Figure 4-15.

**Note:** If the toolbar does not contain “Nu-Link” item, please rework section 4.2.

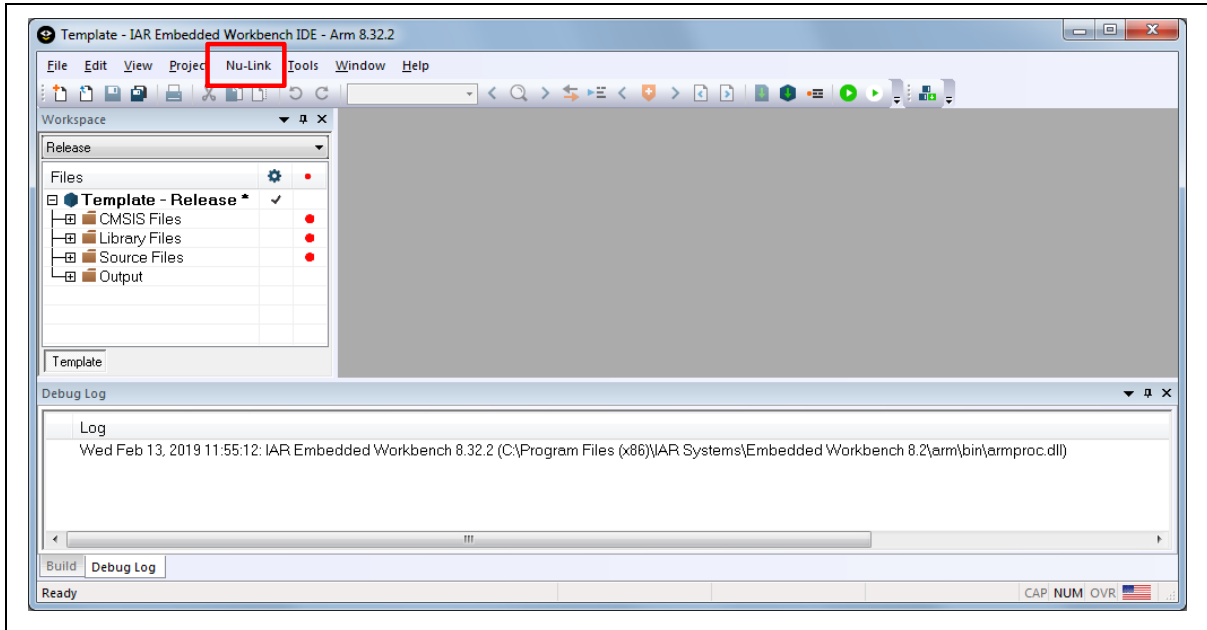

Figure 4-15 IAR EWARM Window

3. Make a target file as presented in Figure 4-16. After successfully compiling the project, download code to the Flash memory and enter debug mode.

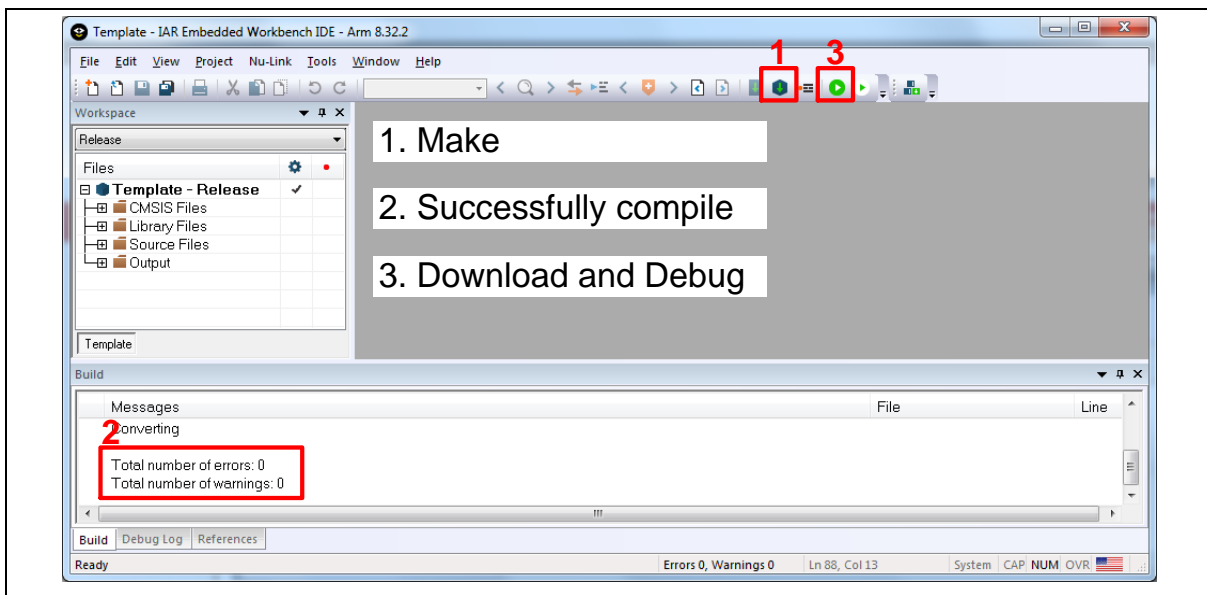

Figure 4-16 Compile and Download the Project

4. Figure 4-17 shows the debug mode under IAR EWARN. Click “Go” and the debug message will be printed out as shown in Figure 4-18. User can debug the project under debug mode by checking source code, assembly language, peripherals’ registers, and setting breakpoint, step run, value monitor, etc.

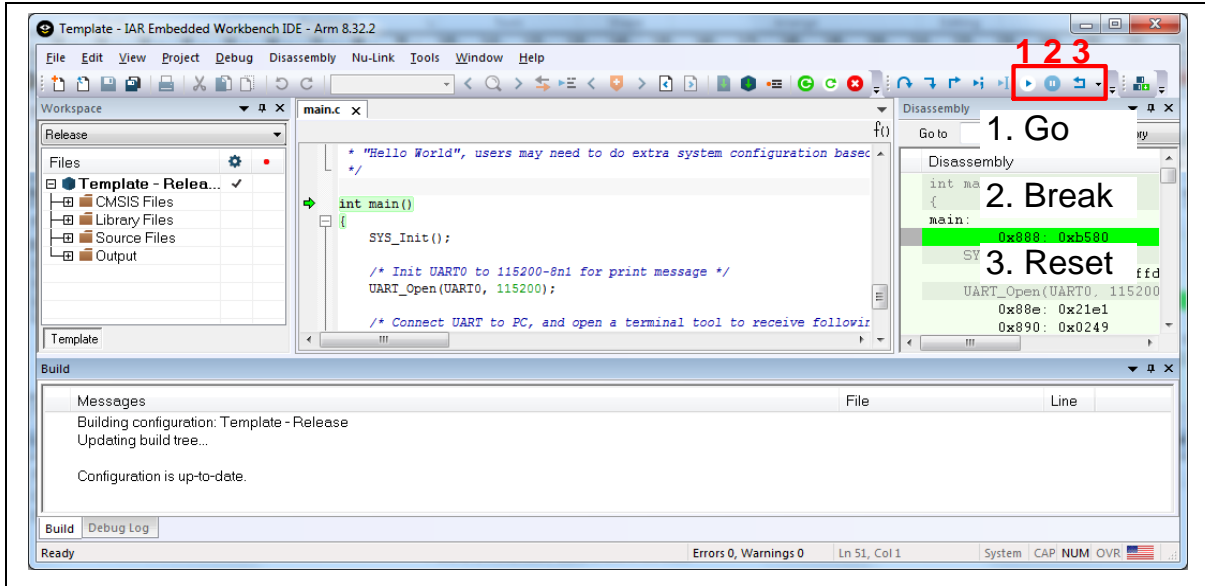

Figure 4-17 IAR EWARM Debug Mode

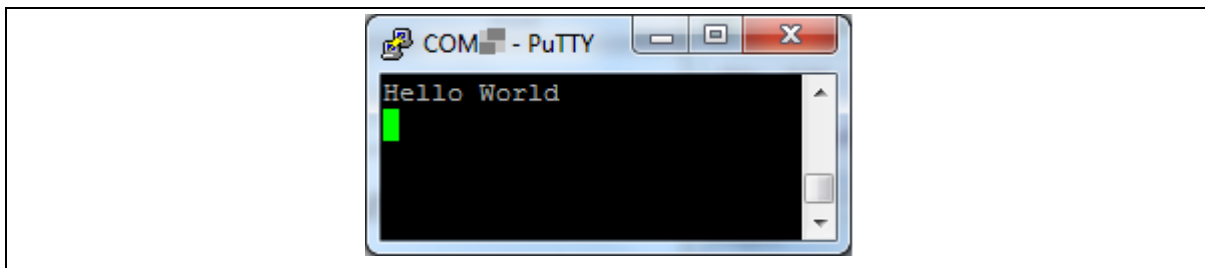

Figure 4-18 Debug Message on Serial Port Terminal Windows

### 4.6.3 NuEclipse

This section provides steps to beginners on how to run a project by using NuEclipse. Please make sure the filenames and project folder path contain neither invalid character nor space.

1. Double-click "NuEclipse.exe" to open the toolchain.
2. Import the "Template" project by following the steps presented in Figure 4-19 and Figure 4-20.

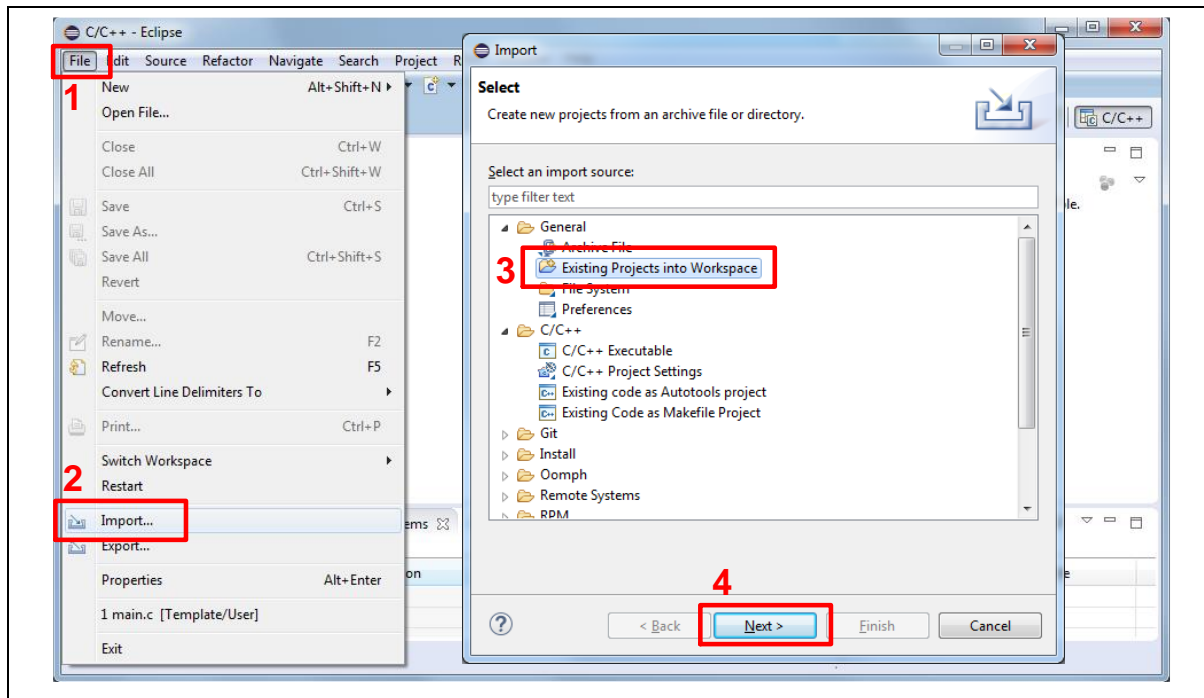

Figure 4-19 Import the Project in NuEclipse



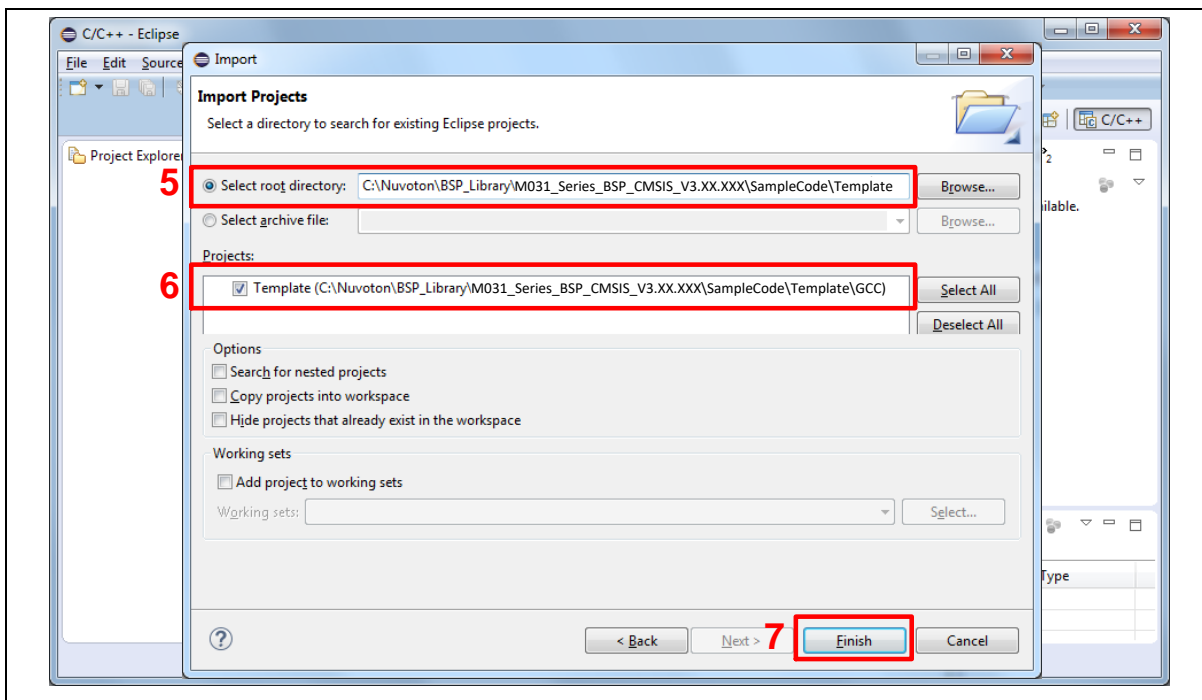

Figure 4-20 Import Projects Windows

3. Click the “Template” project and find the project properties as shown in Figure 4-21. Make sure the settings are the same as settings in Figure 4-22.

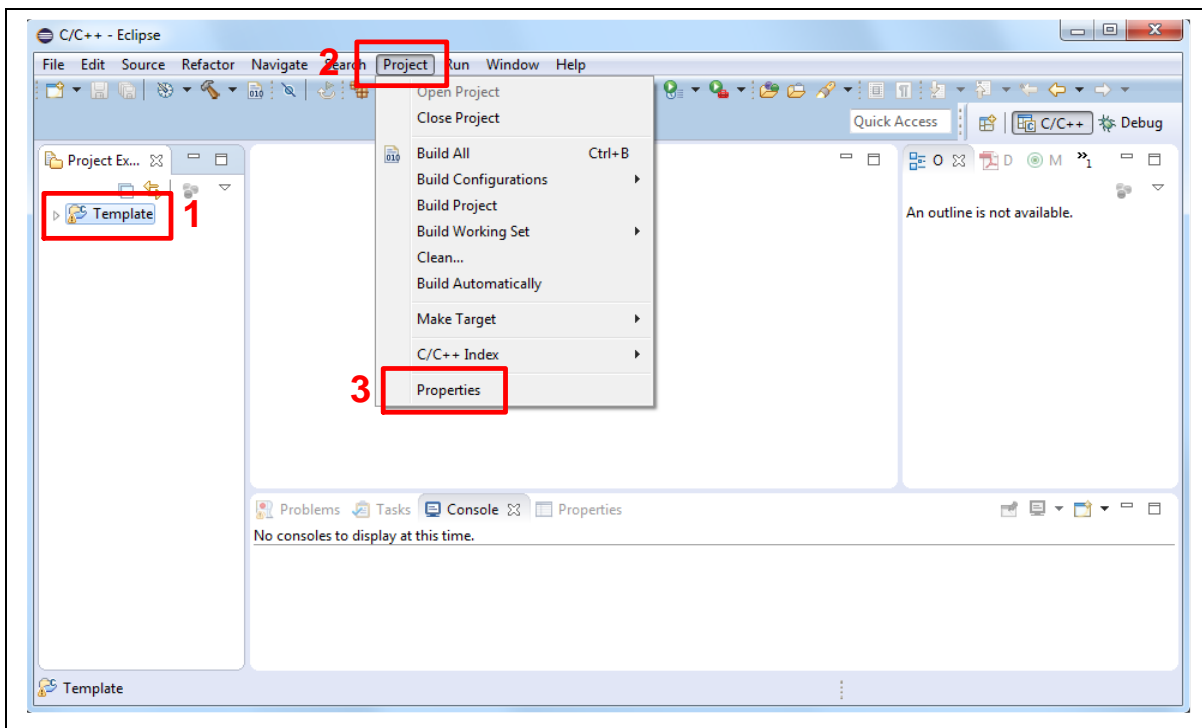

Figure 4-21 Open Project Properties Window

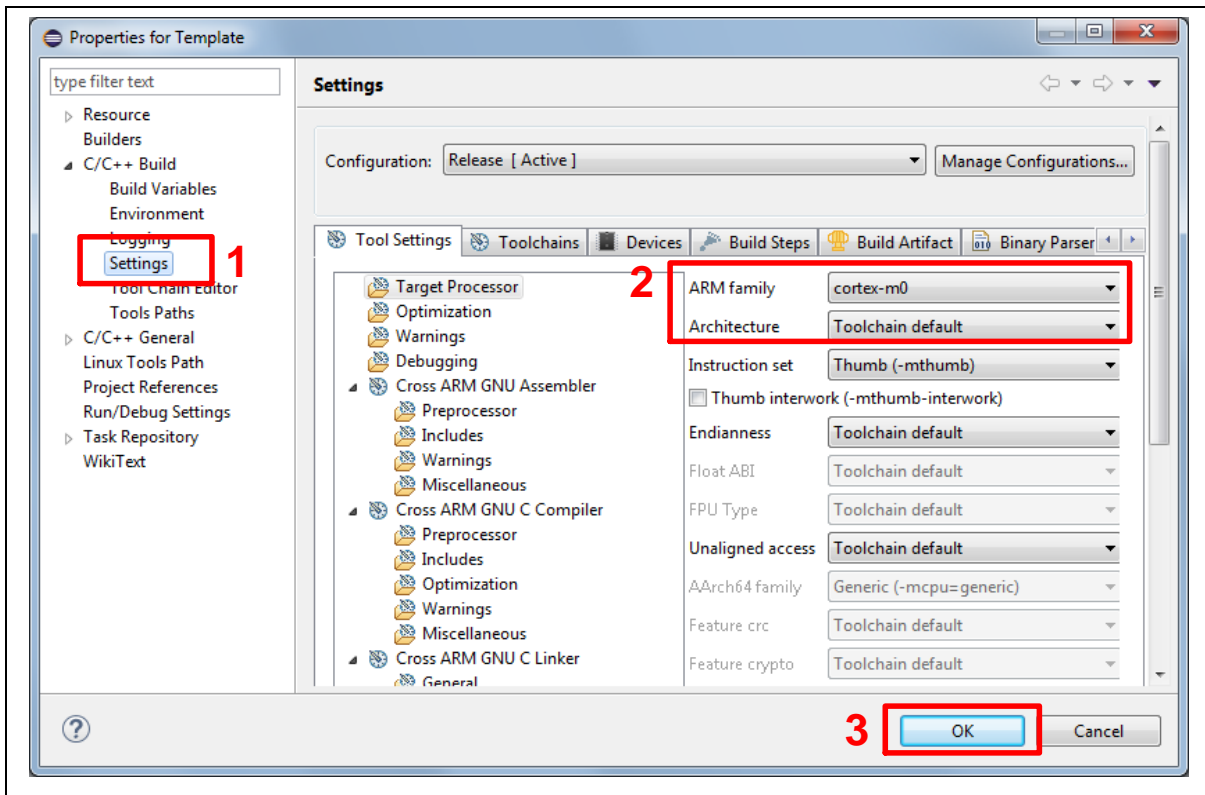

Figure 4-22 Project Properties Settings

4. Click the “Template” project and build the project.

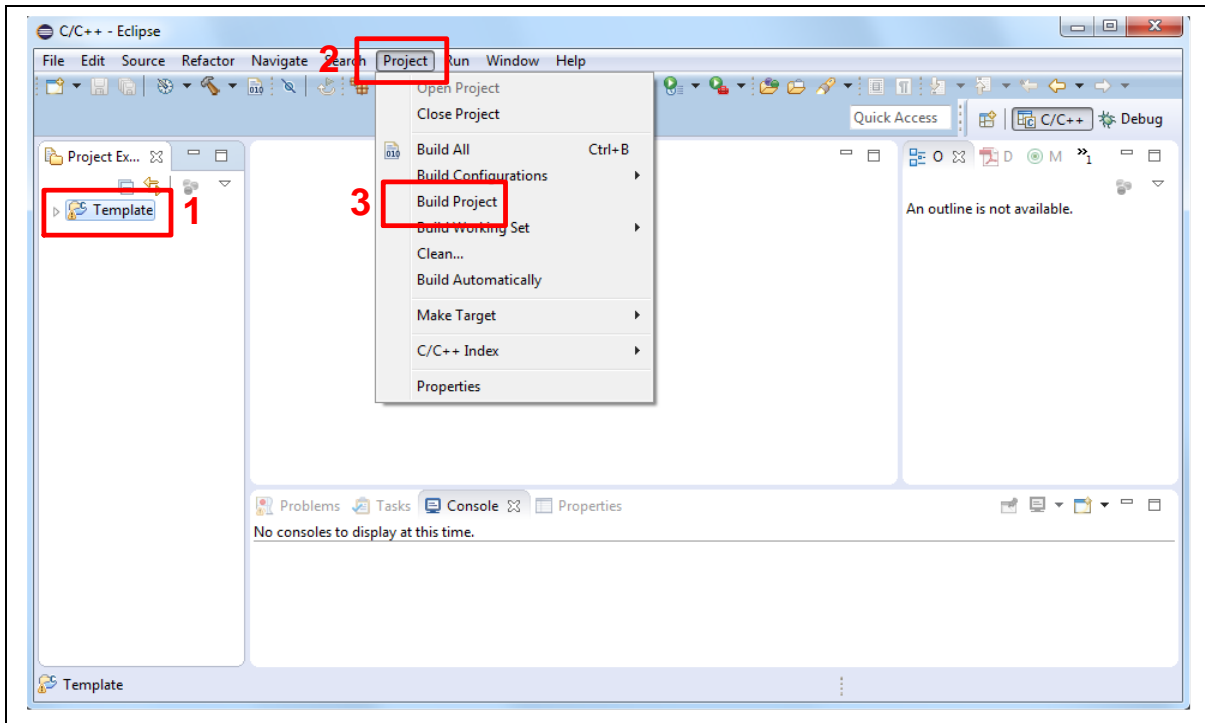

Figure 4-23 Build Project

5. After the project is built, click the “Template” project and set the “Debug Configuration” as shown in Figure 4-24. Follow the settings presented in Figure 4-25, Figure 4-26 and Figure 4-27 to enter debug mode.

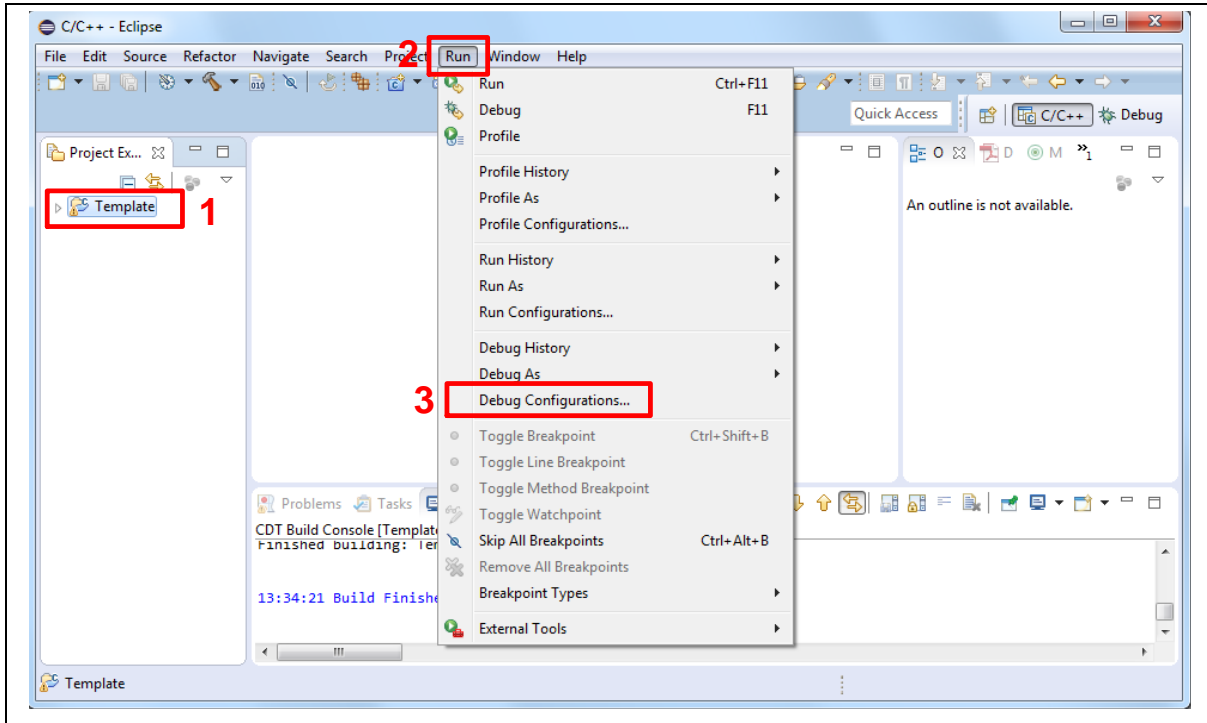
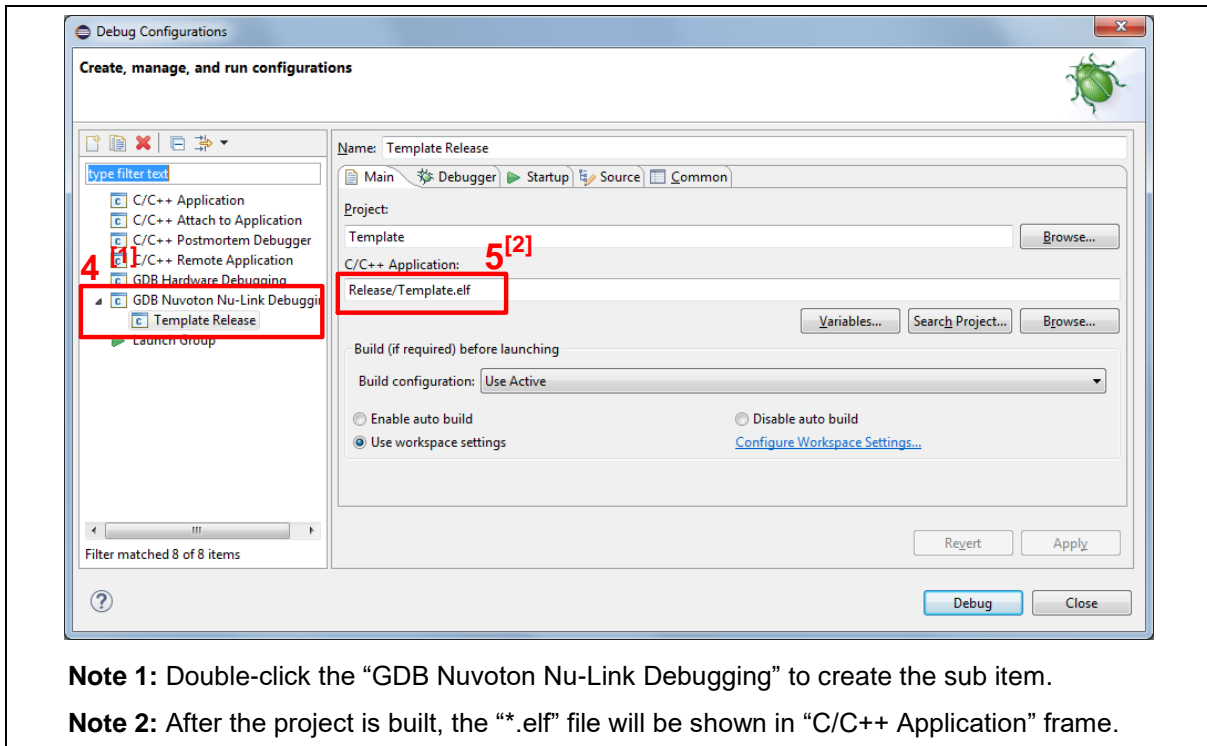

Figure 4-24 Open Debug Configuration



**Note 1:** Double-click the “GDB Nuvoton Nu-Link Debugging” to create the sub item.

**Note 2:** After the project is built, the “\*.elf” file will be shown in “C/C++ Application” frame.

Figure 4-25 Main Tab Configuration

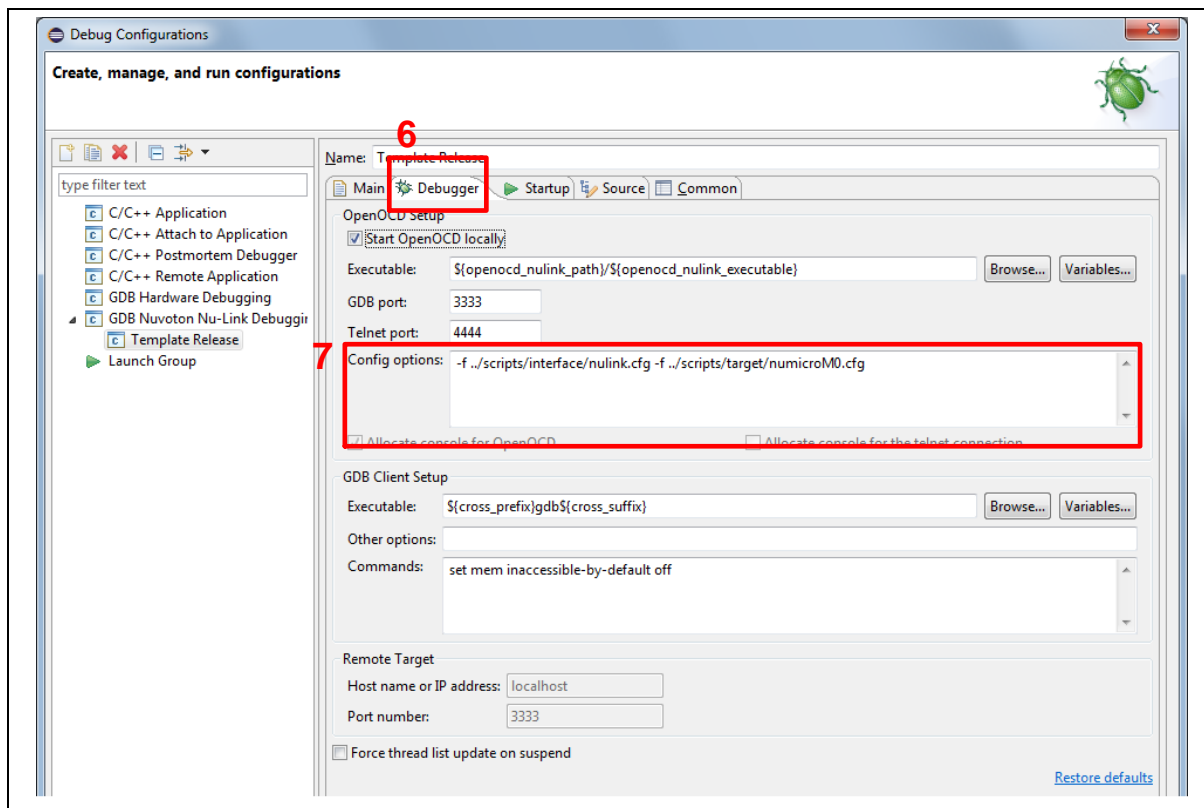
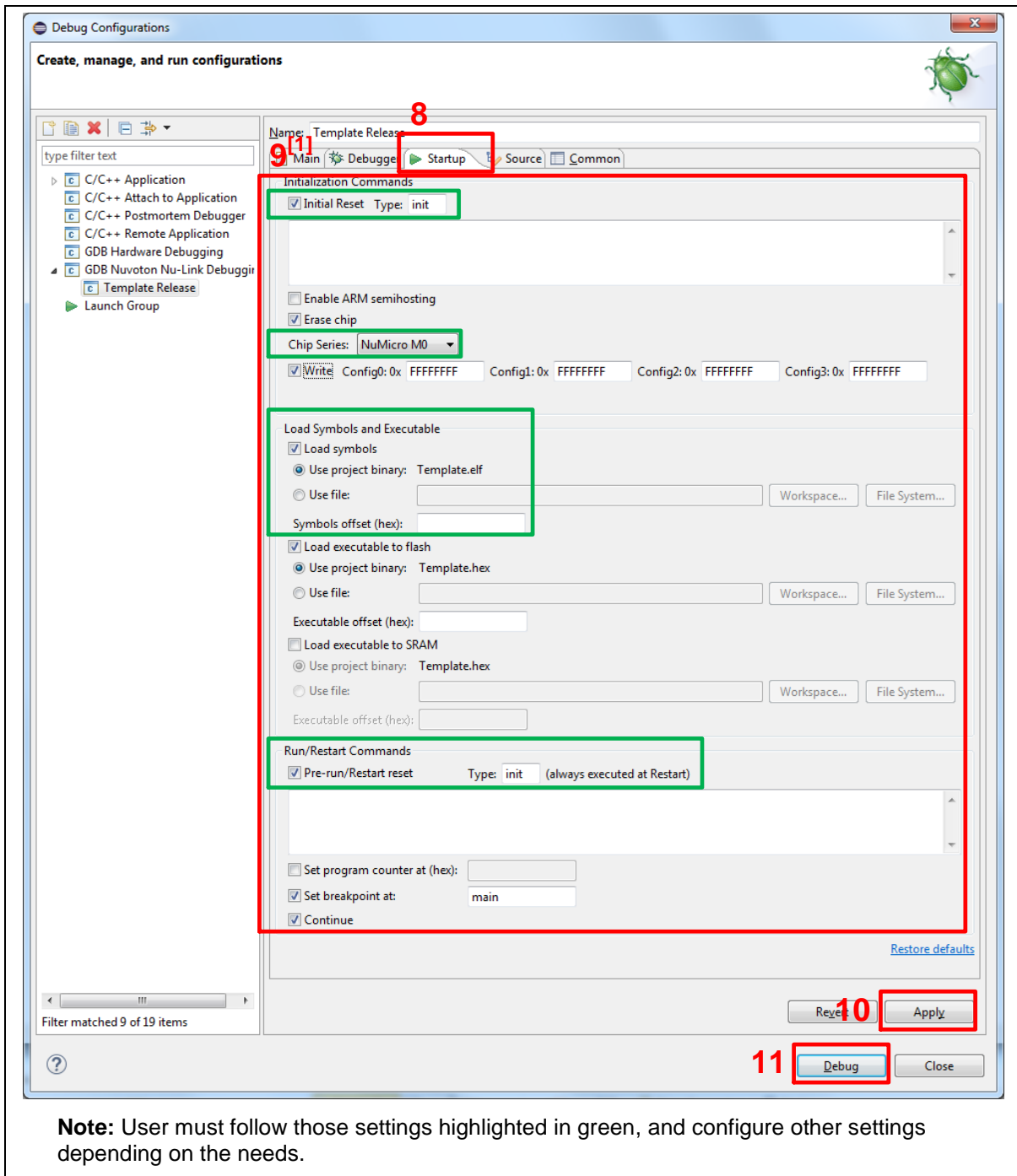

Figure 4-26 Debugger Tab Configuration



**Note:** User must follow those settings highlighted in green, and configure other settings depending on the needs.

Figure 4-27 Startup Tab Configuration

6. Figure 4-28 shows the debug mode under NuEclipse. Click “Resume” and the debug message will be printed out as shown in Figure 4-29. User can debug the project under debug mode by checking source code, assembly language, peripherals’ registers, and setting breakpoint, step run, value monitor, etc. For more information about how to use NuEclipse, please refer to the *NuEclipse User Manual*.

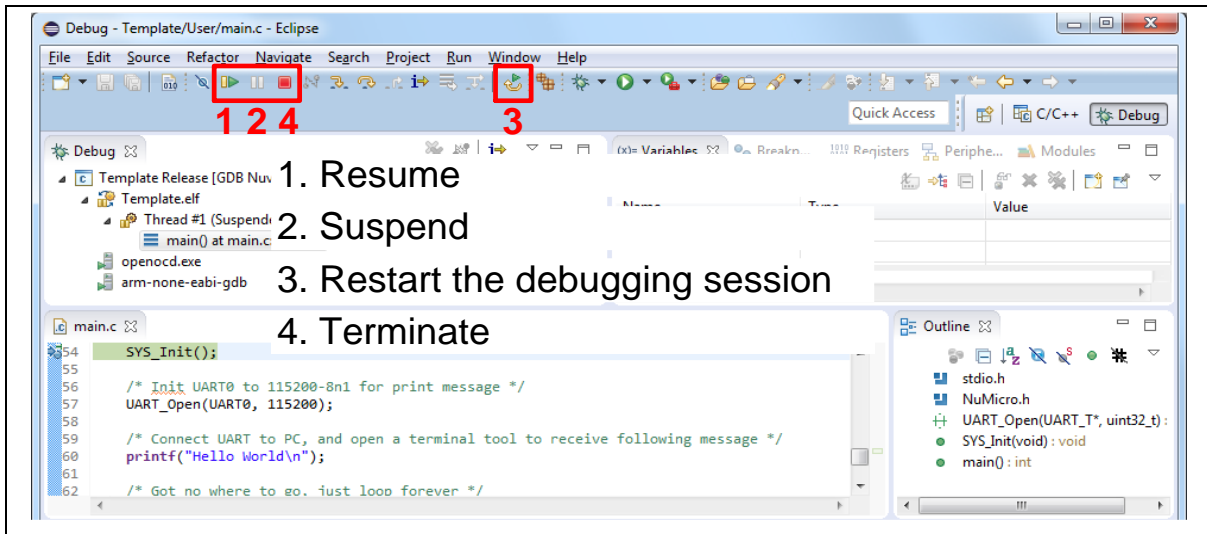

Figure 4-28 NuEclipse Debug Mode

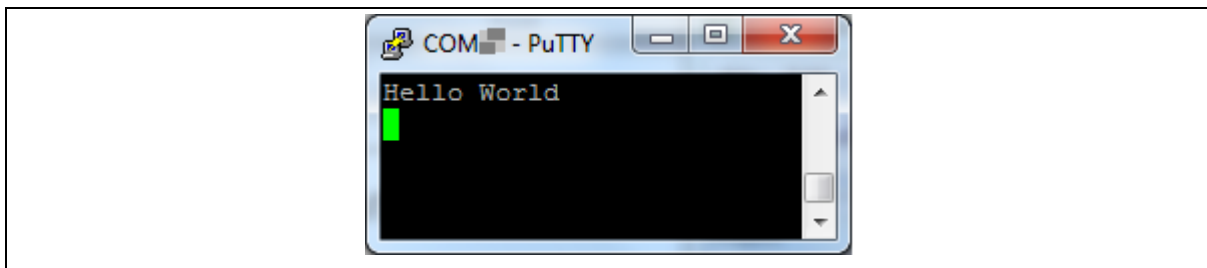

Figure 4-29 Debug Message on Serial Port Terminal Windows





## 5.2 M467HJ Target Board

### 5.2.1 Power Source

Figure 5-2 shows the power source circuit.

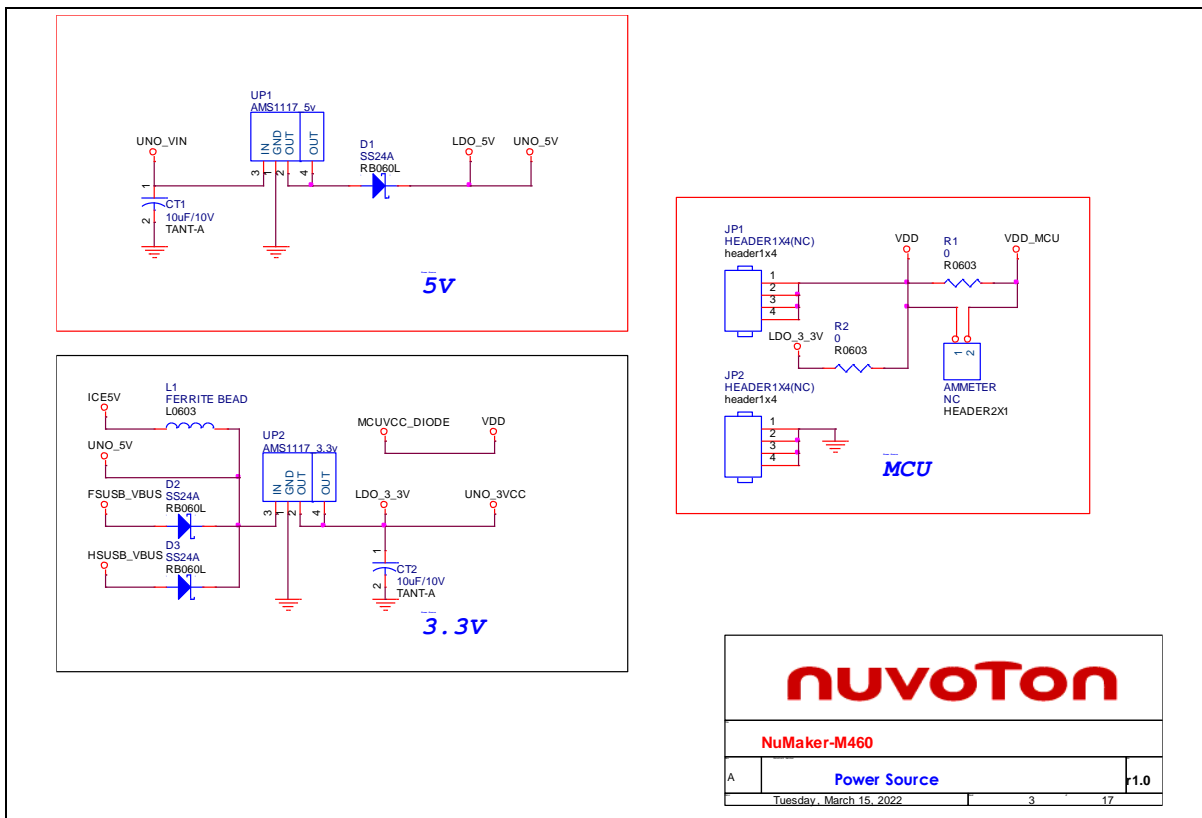

Figure 5-2 Power Source Circuit

5.2.2 M467HJHAN

Figure 5-3 shows the M467HJHAN circuit.

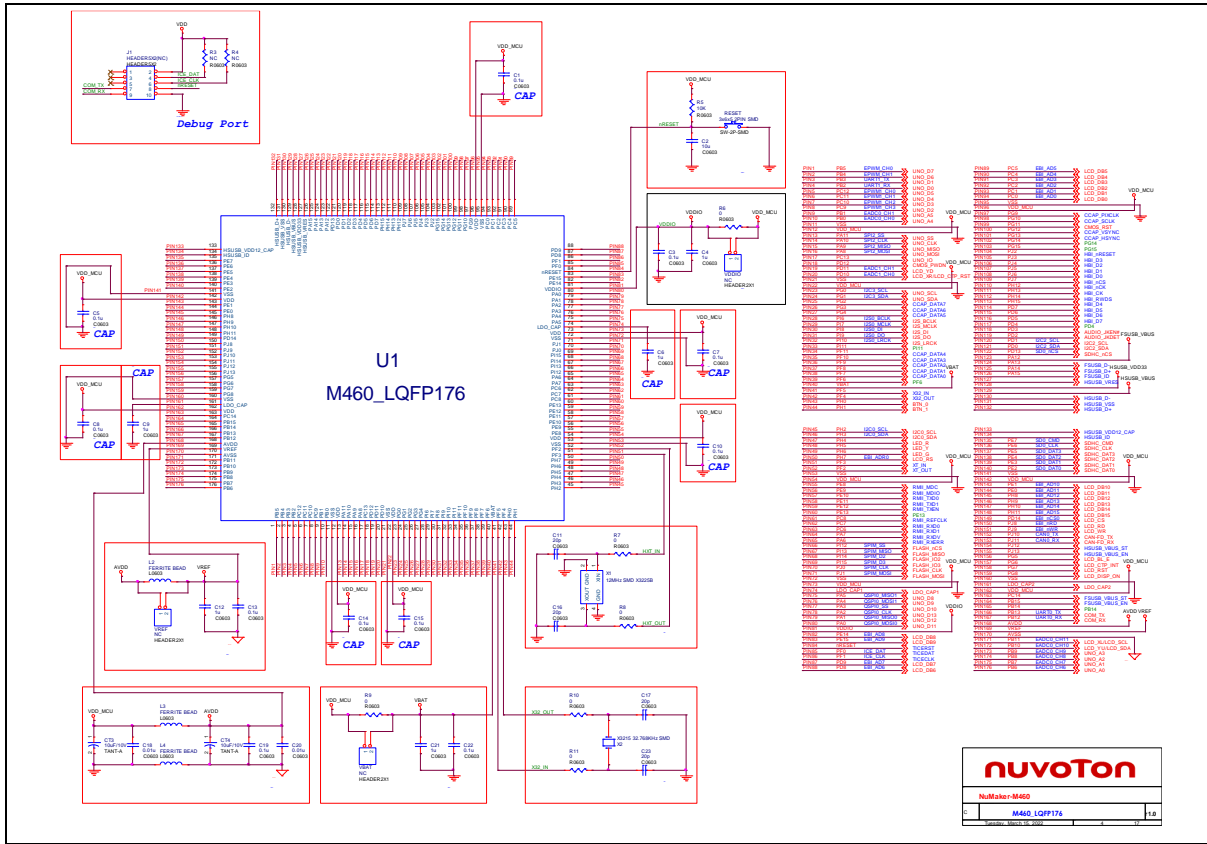

Figure 5-3 M467HJHAN Circuit

5.2.3 HyperRAM

Figure 5-4 shows the HyperRAM circuit.

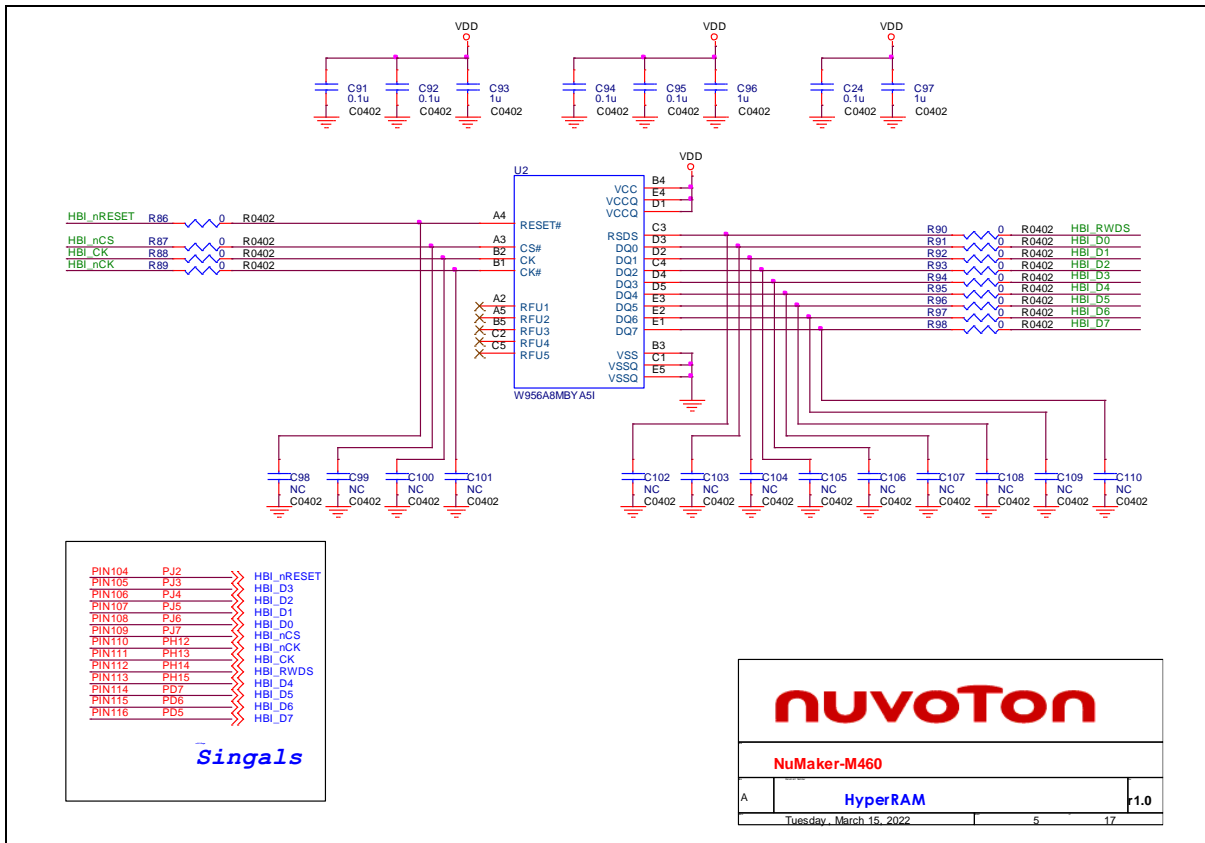

Figure 5-4 HyperRAM Circuit

5.2.4 SPI Flash

Figure 5-5 shows the SPI flash circuit.

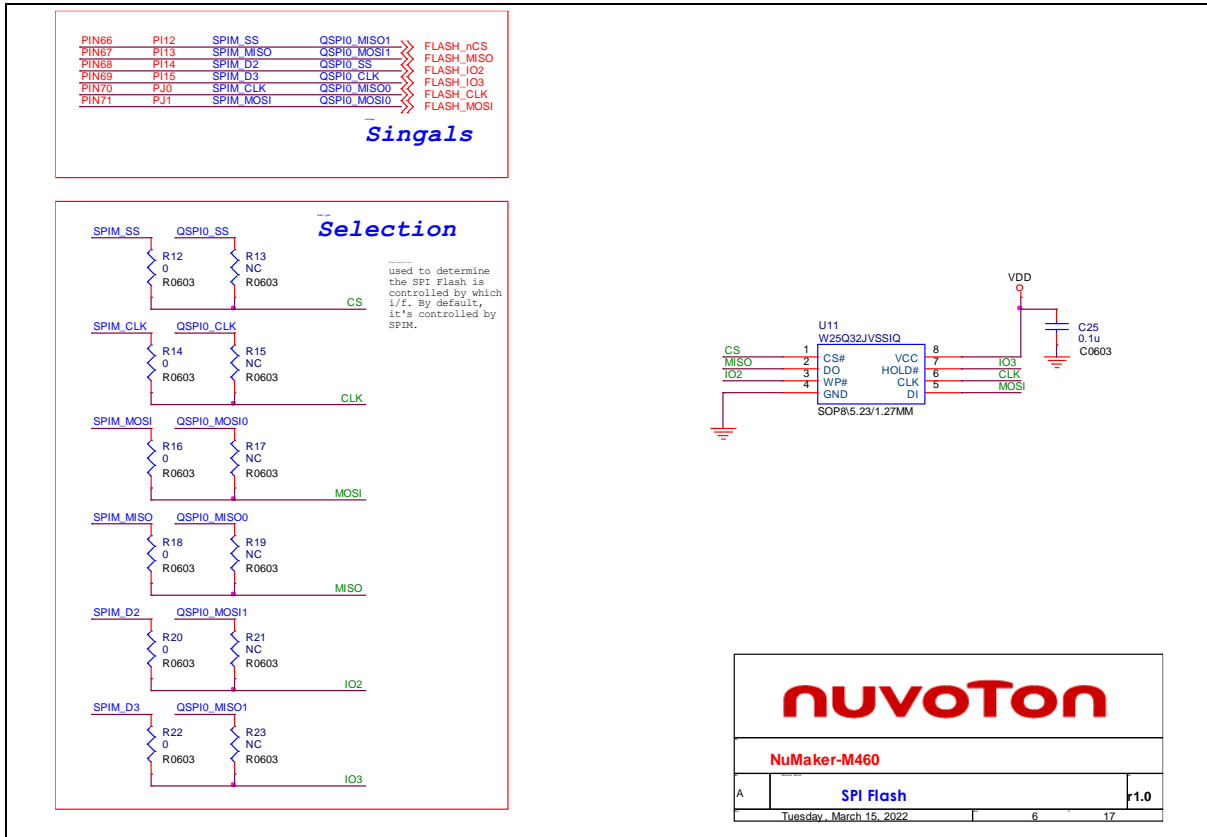

Figure 5-5 SPI Flash Circuit





5.2.6 High-speed USB

Figure 5-7 shows the high-speed USB circuit.

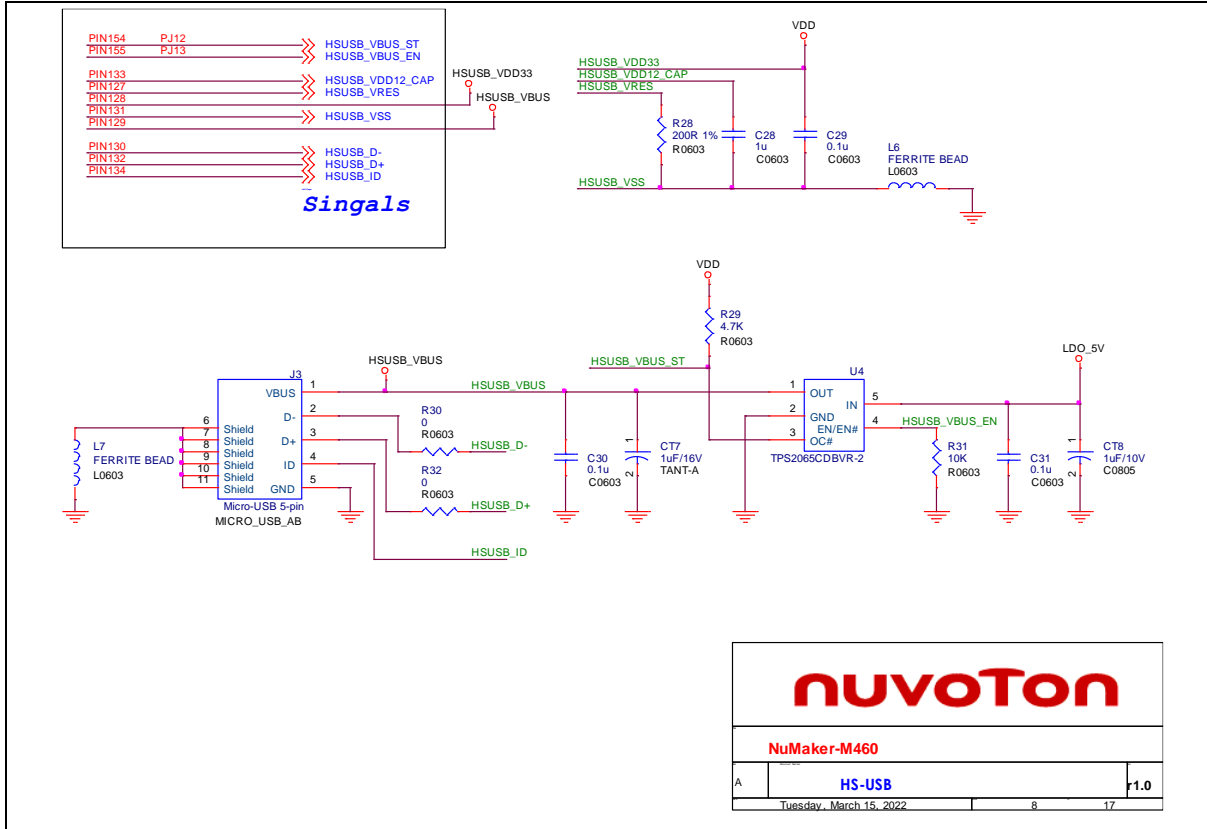

Figure 5-7 High-speed Circuit

5.2.7 SD Card

Figure 5-8 shows the SD card circuit.

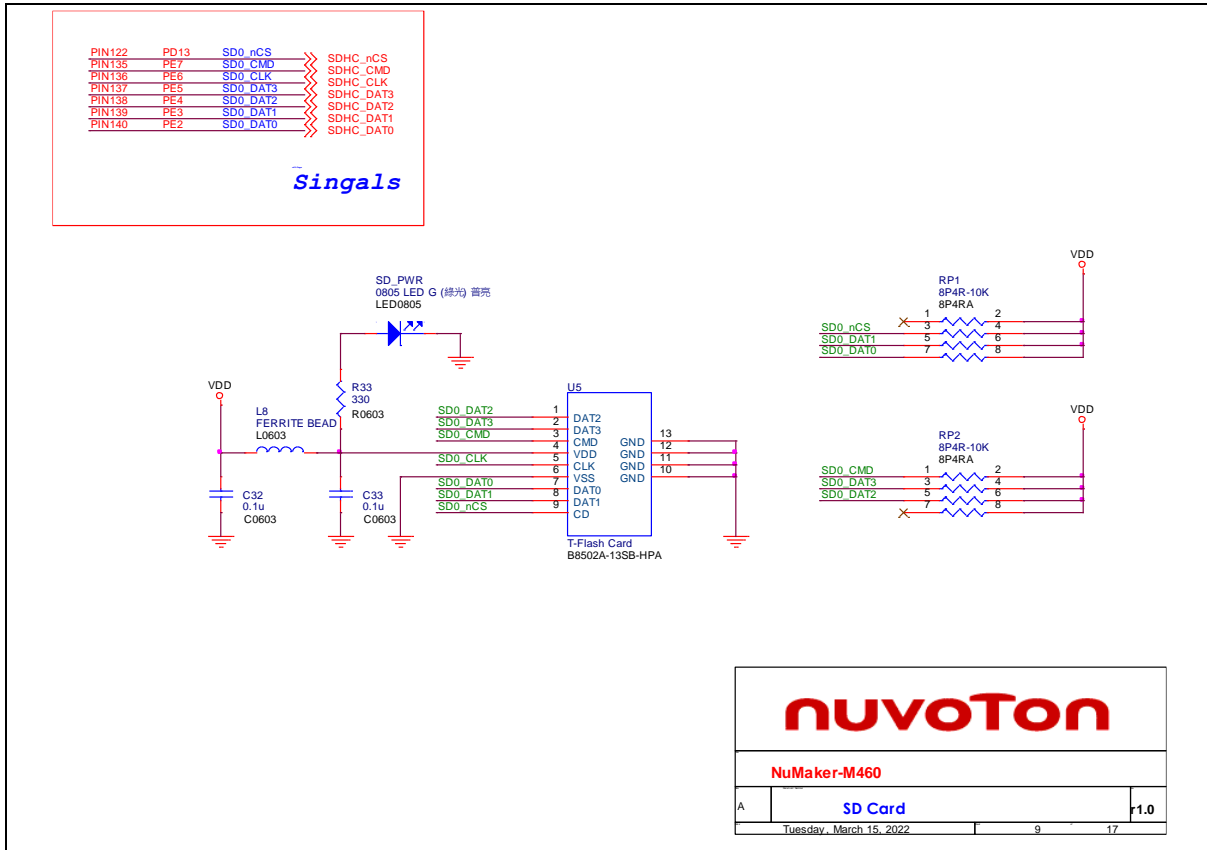

Figure 5-8 SD Card Circuit

5.2.8 Extension Connectors

Figure 5-9 shows the extension connectors circuit.

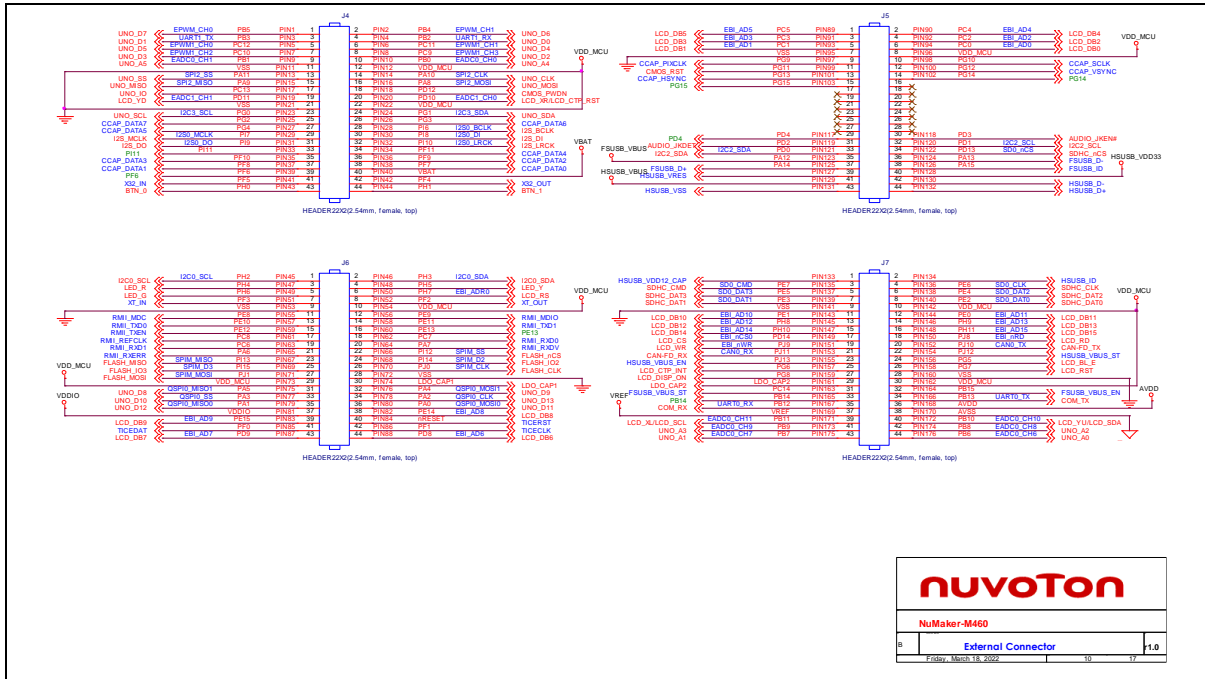

Figure 5-9 Extension Connectors Circuit



5.2.9 Arduino UNO I/F

Figure 5-10 shows the Arduino UNO interface circuit.

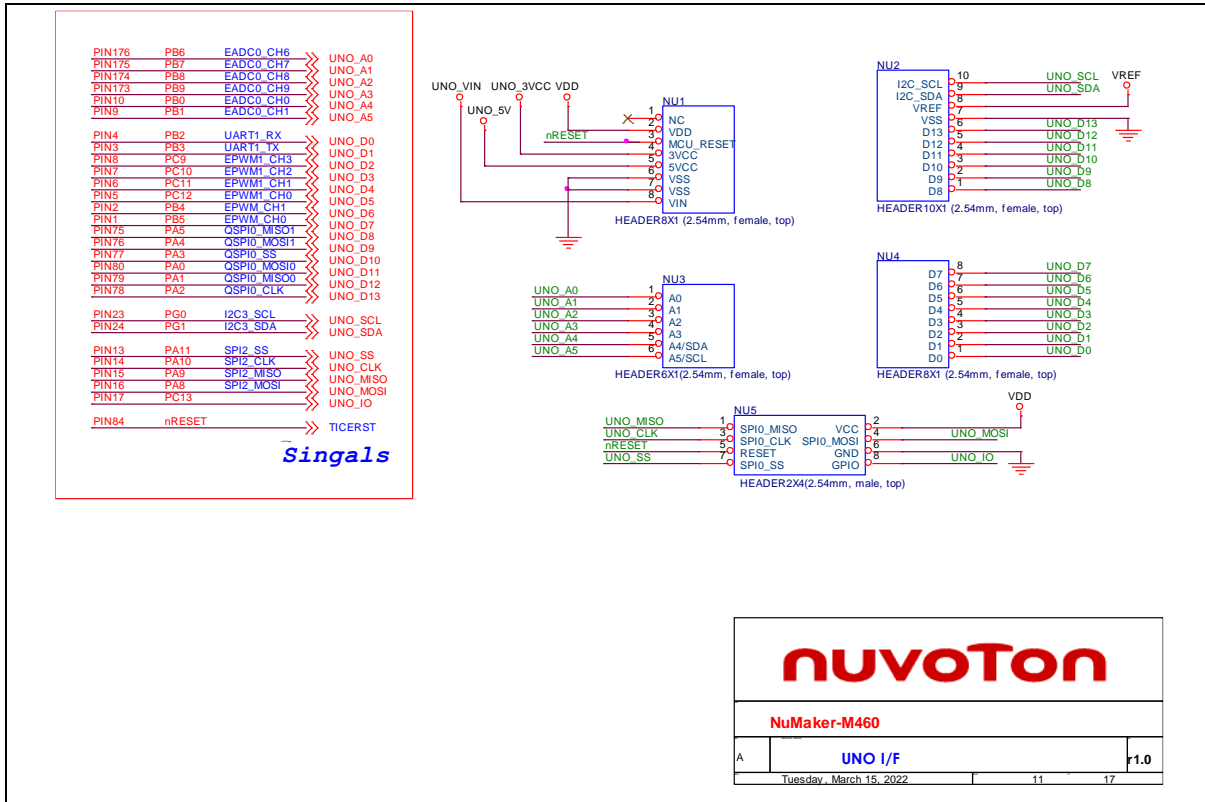

Figure 5-10 Arduino Uno I/F Circuit

5.2.10 COMS I/F & LCD I/F

Figure 5-11 shows the COMS and LCD interface circuit.

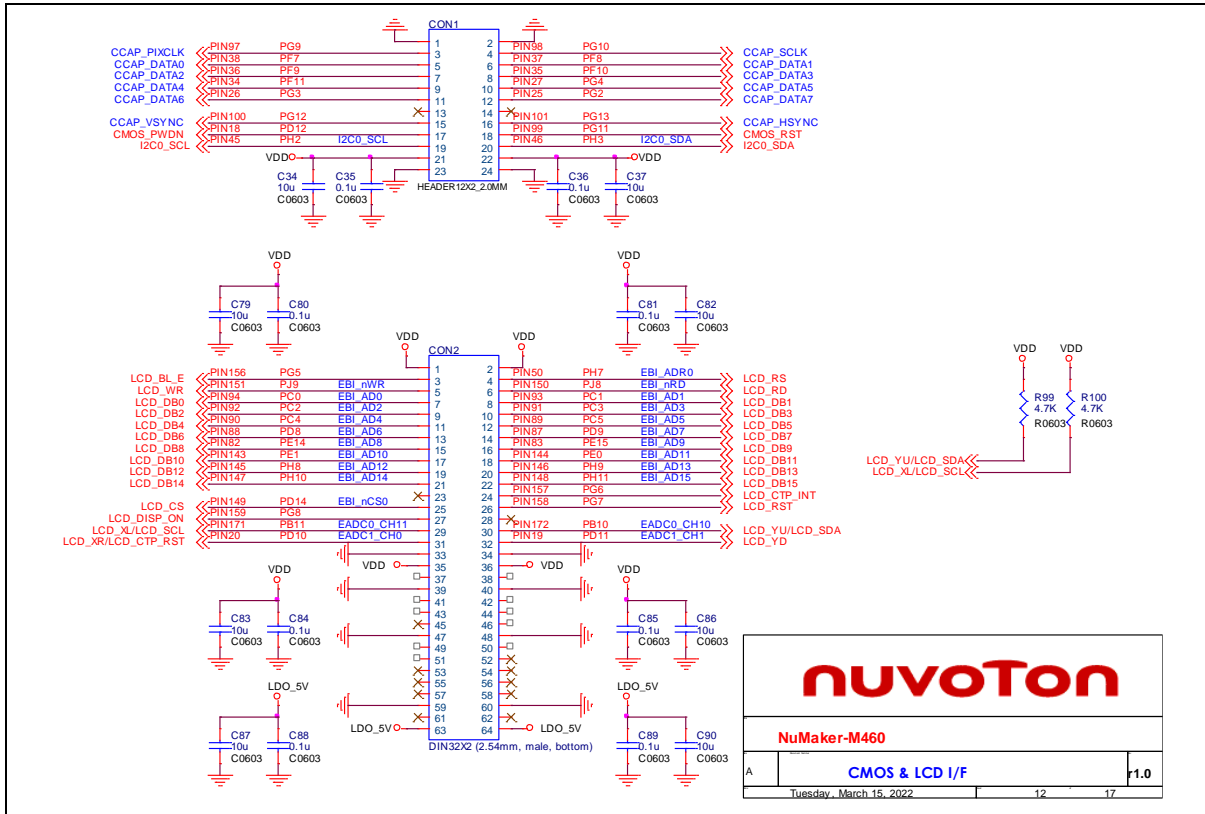

Figure 5-11 COMS and LCD I/F Circuit

5.2.11 CAN FD Transceiver

Figure 5-12 shows the CAN FD transceiver circuit.

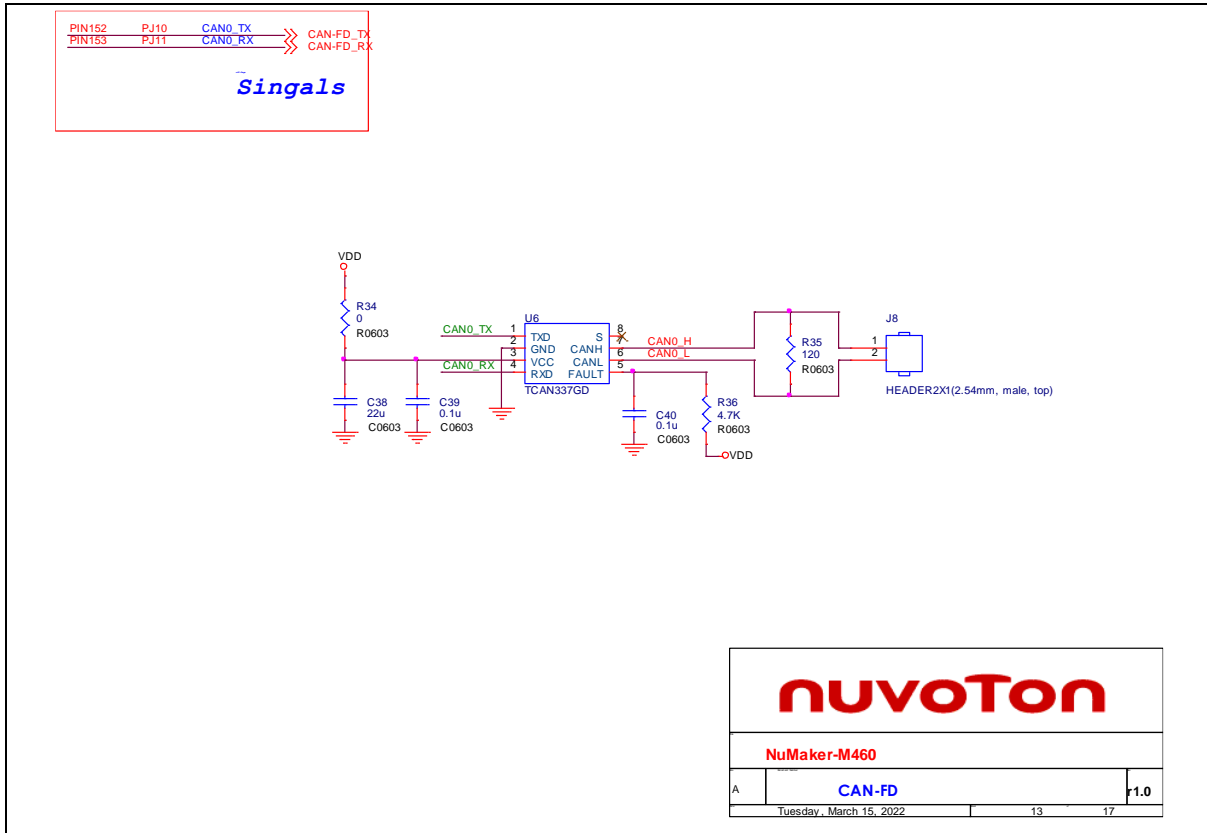

Figure 5-12 CAN FD Transceiver Circuit





5.2.13 Audio

Figure 5-14 shows the audio circuit.

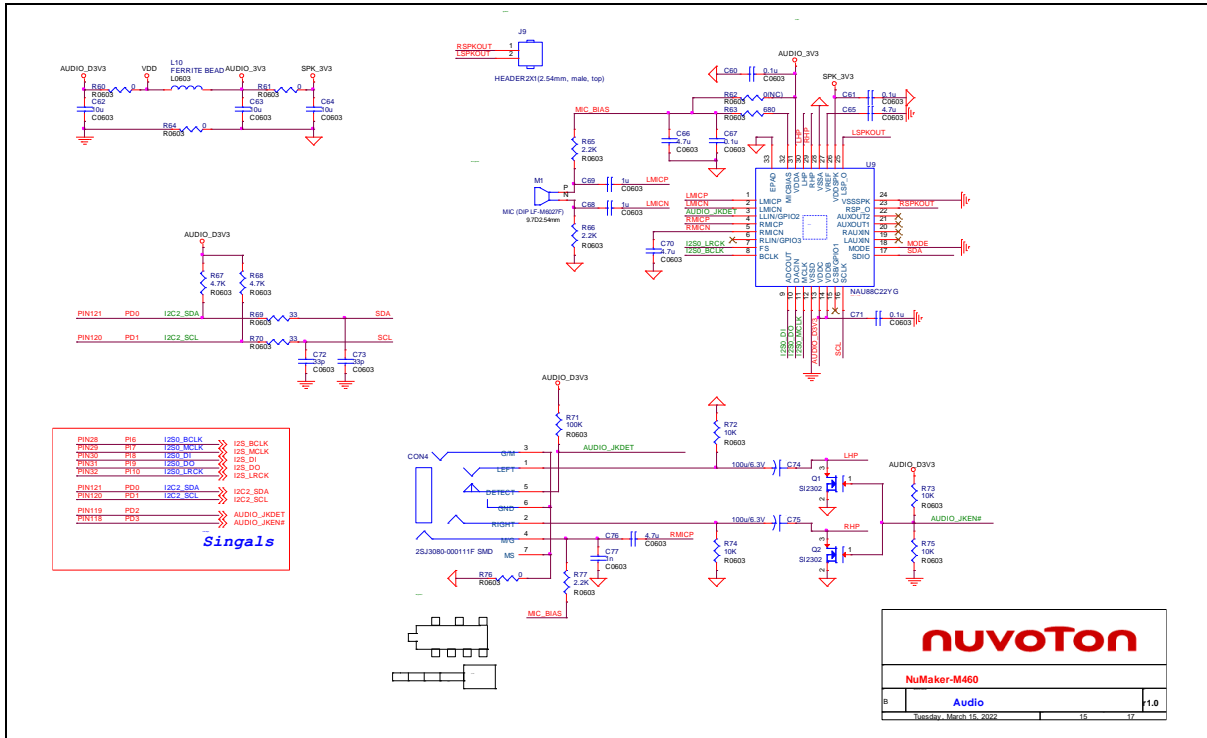

Figure 5-14 Audio Circuit

5.2.14 Thermal Sensor

Figure 5-15 shows the thermal sensor circuit.

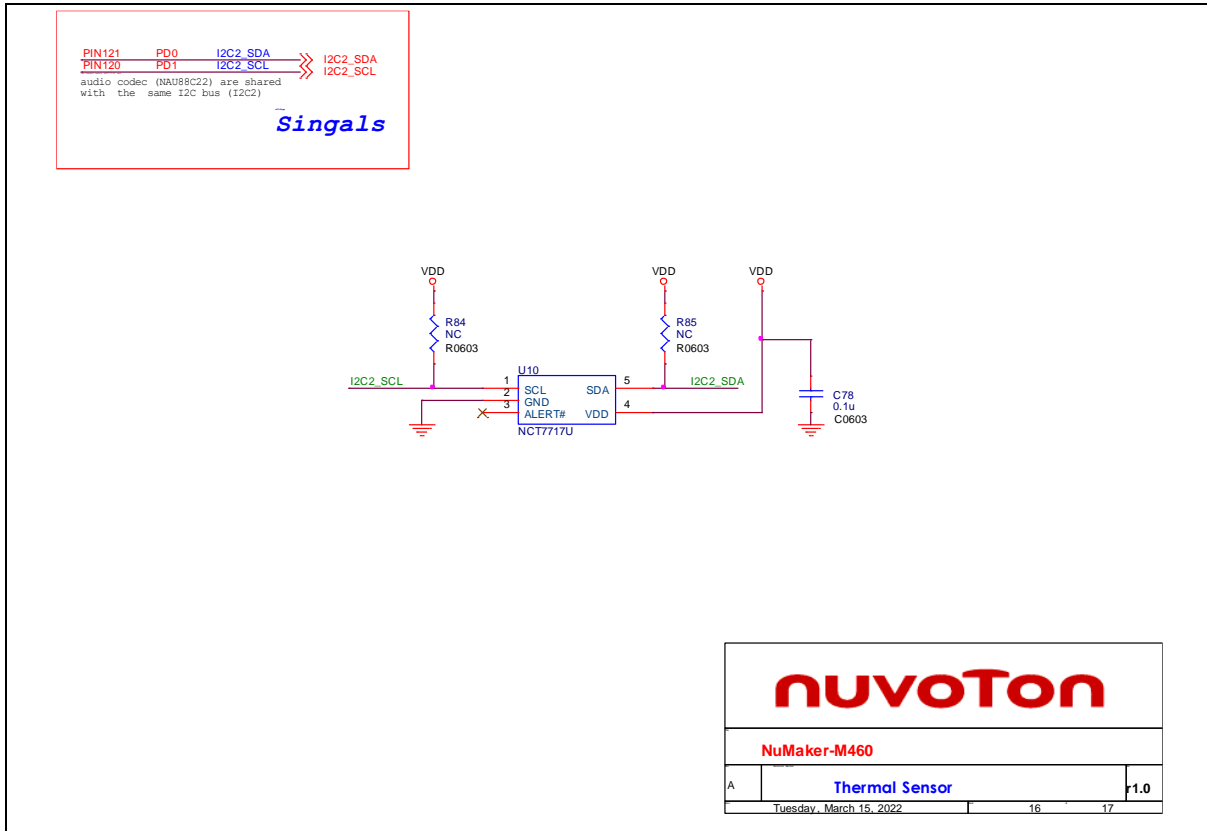

Figure 5-15 Thermal Sensor Circuit

5.2.15 LEDs & Buttons

Figure 5-16 shows the LEDs and buttons circuit.

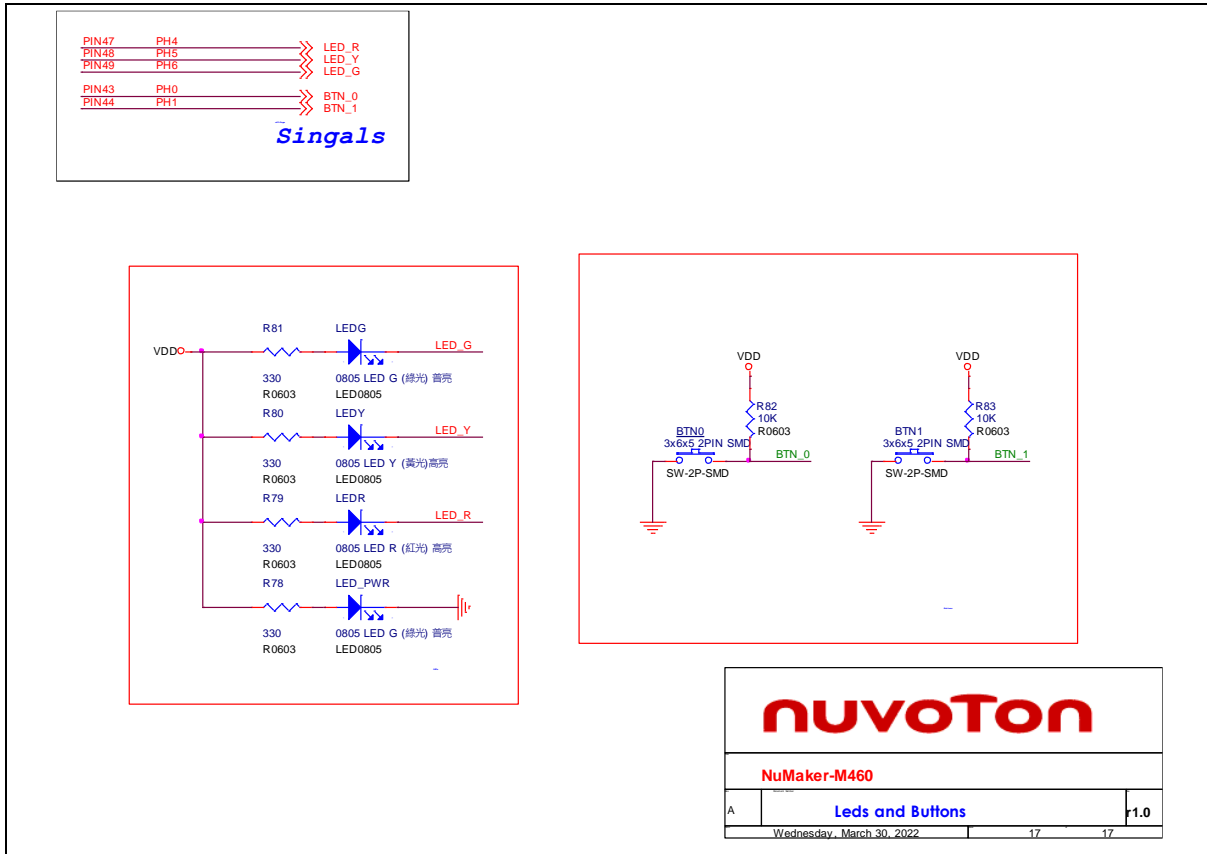

Figure 5-16 LEDs and Buttons Circuit

**6 REVISION HISTORY**

Date	Revision	Description
2022.06.28	1.00	Initial version.

### Important Notice

**Nuvoton Products are neither intended nor warranted for usage in systems or equipment, any malfunction or failure of which may cause loss of human life, bodily injury or severe property damage. Such applications are deemed, “Insecure Usage”.**

**Insecure usage includes, but is not limited to: equipment for surgical implementation, atomic energy control instruments, airplane or spaceship instruments, the control or operation of dynamic, brake or safety systems designed for vehicular use, traffic signal instruments, all types of safety devices, and other applications intended to support or sustain life.**

**All Insecure Usage shall be made at customer’s risk, and in the event that third parties lay claims to Nuvoton as a result of customer’s Insecure Usage, customer shall indemnify the damages and liabilities thus incurred by Nuvoton.**

---

*Please note that all data and specifications are subject to change without notice.  
All the trademarks of products and companies mentioned in this datasheet belong to their respective owners.*